

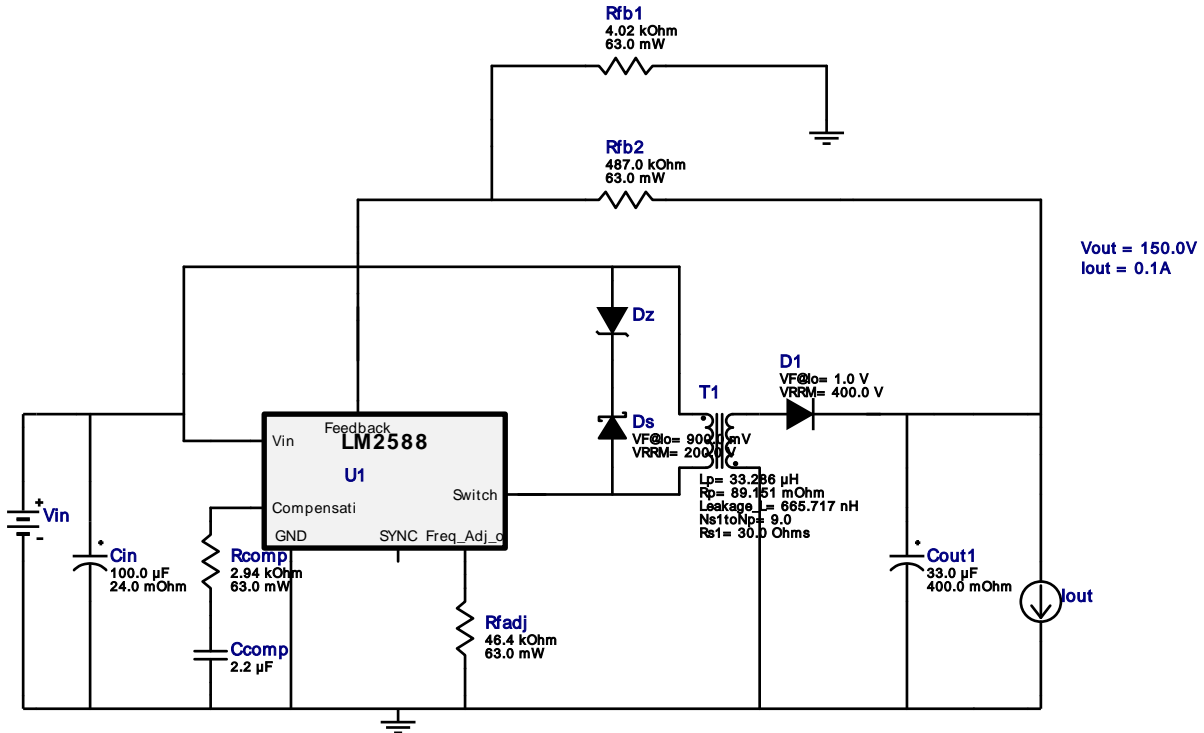





WEBENCH® Design Report

 Design : 4789768/14 LM2588T-ADJ/NOPB
 Copy of Design #8

My Comments

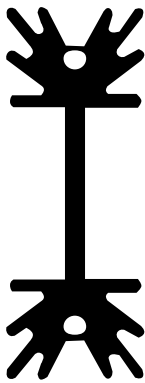
Brian

Electrical BOM

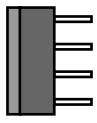
#	Name	Manufacturer	Part Number	Properties	Qty	Price	Footprint
1.	Ccomp	Taiyo Yuden	EMK212BJ225KG-T Series= X5R	Cap= 2.2 uF VDC= 16.0 V IRMS= 0.0 A	1	\$0.02	0805 7 mm ²
2.	Cin	Panasonic	25SVPF100M Series= SVPF	Cap= 100.0 uF ESR= 24.0 mOhm VDC= 25.0 V IRMS= 3.2 A	1	\$0.50	CAPSMT_62_E7 106 mm ²
3.	Cout1	Panasonic	EEV-EB2E330SM Series= ?	Cap= 33.0 uF ESR= 400.0 mOhm VDC= 250.0 V IRMS= 560.0 mA	1	\$1.25	EB_K16 483 mm ²
4.	D1	SMC Diode Solutions	UF4004TA	VF@Io= 1.0 V VRRM= 400.0 V	1	\$0.04	DO-41 43 mm ²
5.	Ds	SMC Diode Solutions	SK220ATR	VF@Io= 900.0 mV VRRM= 200.0 V	1	\$0.05	SMA 37 mm ²

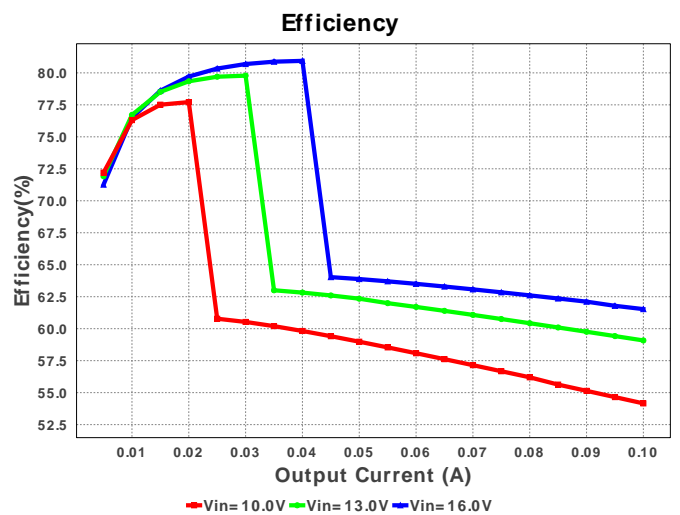
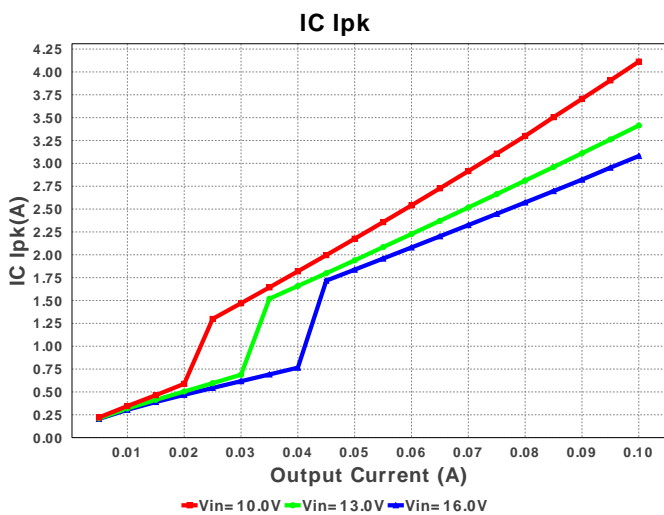
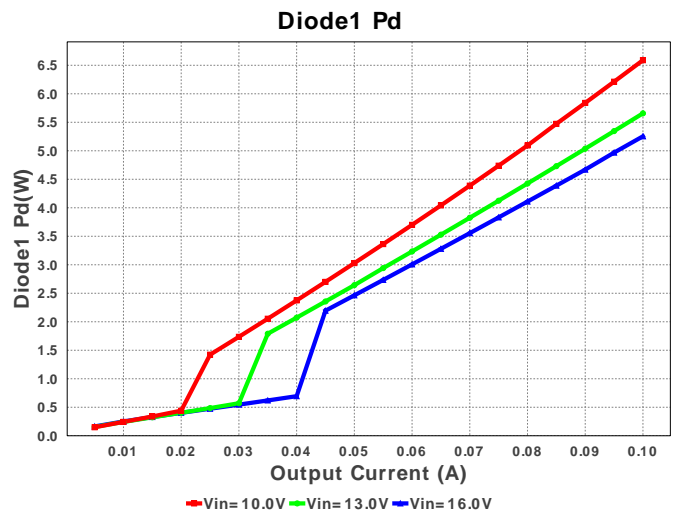
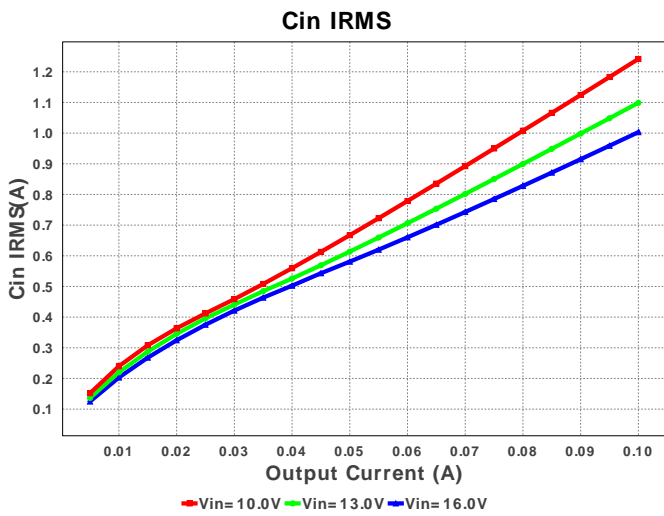
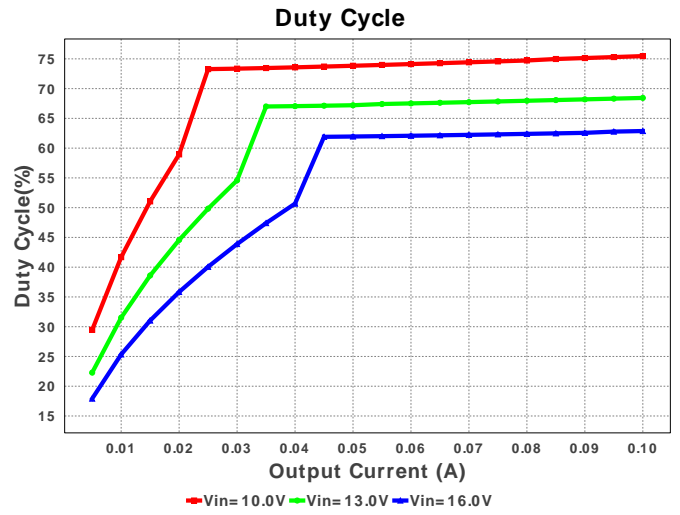
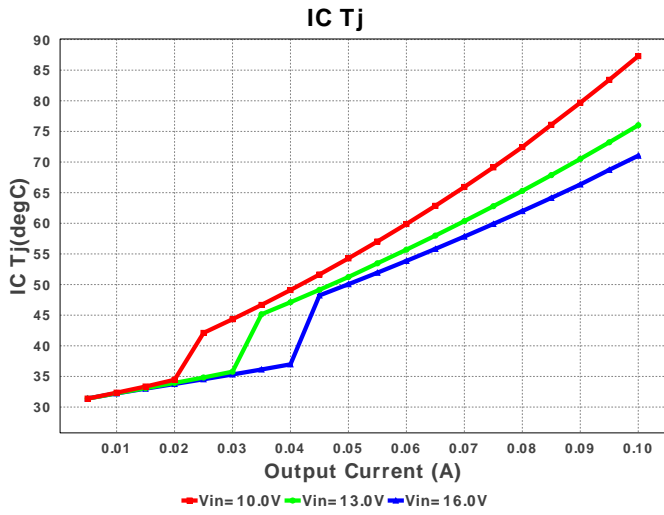
#	Name	Manufacturer	Part Number	Properties	Qty	Price	Footprint
6.	Dz	Diodes Inc.	SMBJ33A-13-F	Zener	1	\$0.09	 SMB 44 mm ²
7.	HeatSink	Aavid	531102B02500G	Heatsink	1	\$0.81	 531102 545 mm ²
8.	Rcomp	Vishay-Dale	CRCW04022K94FKED Series= CRCW..e3	Res= 2.94 kOhm Power= 63.0 mW Tolerance= 1.0%	1	\$0.01	 0402 3 mm ²
9.	Rfadj	Vishay-Dale	CRCW040246K4FKED Series= CRCW..e3	Res= 46.4 kOhm Power= 63.0 mW Tolerance= 1.0%	1	\$0.01	 0402 3 mm ²
10.	Rfb1	Vishay-Dale	CRCW04024K02FKED Series= CRCW..e3	Res= 4.02 kOhm Power= 63.0 mW Tolerance= 1.0%	1	\$0.01	 0402 3 mm ²
11.	Rfb2	Vishay-Dale	CRCW0402487KFKED Series= CRCW..e3	Res= 487.0 kOhm Power= 63.0 mW Tolerance= 1.0%	1	\$0.01	 0402 3 mm ²
12.	T1	CUSTOM	CUSTOM	Lp= 33.286 µH Rp= 89.151 mOhm Leakage_L= 665.717 nH Ns1toNp= 9.0 Rs1= 30.0 Ohms	1	NA	CUSTOM 0 mm ²
13.	U1	Texas Instruments	LM2588T-ADJ/NOPB	Switcher	1	\$4.25	 TA07B 121 mm ²



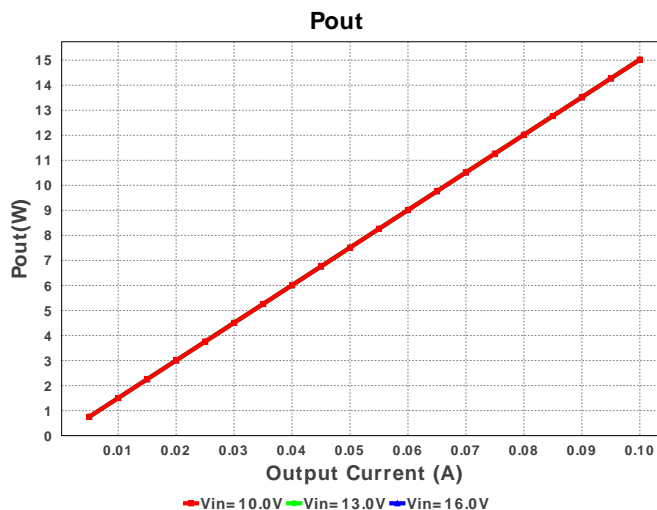
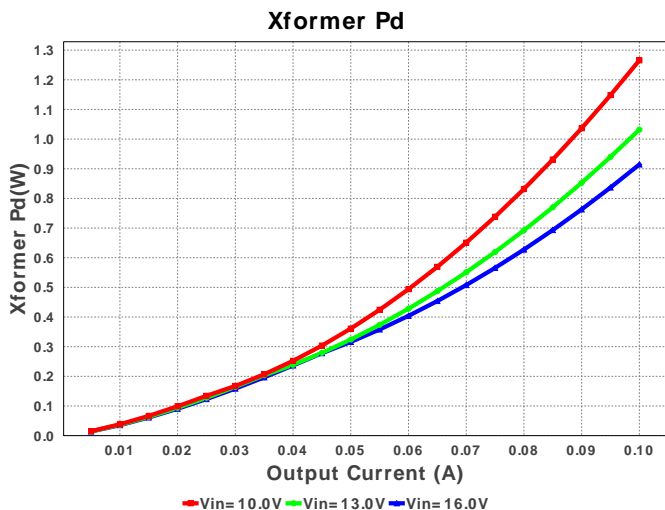
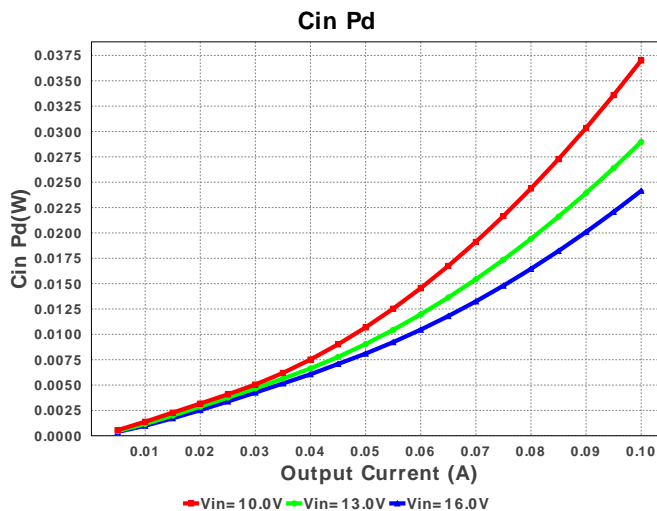
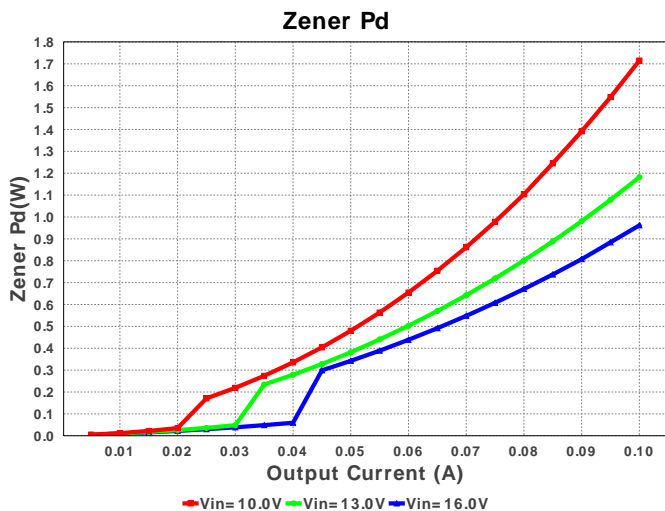
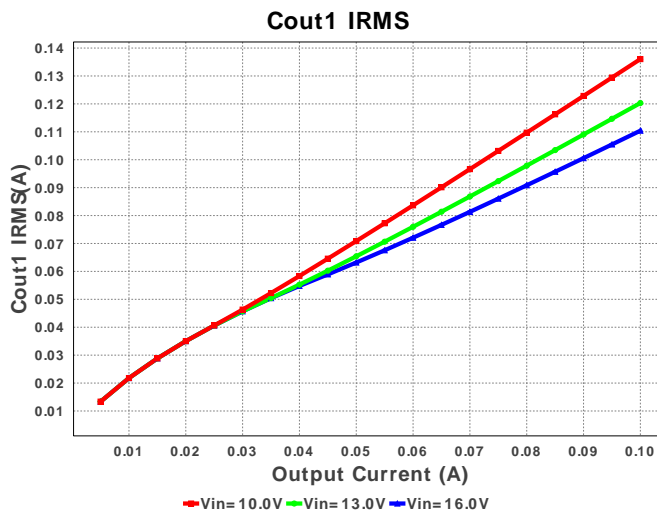
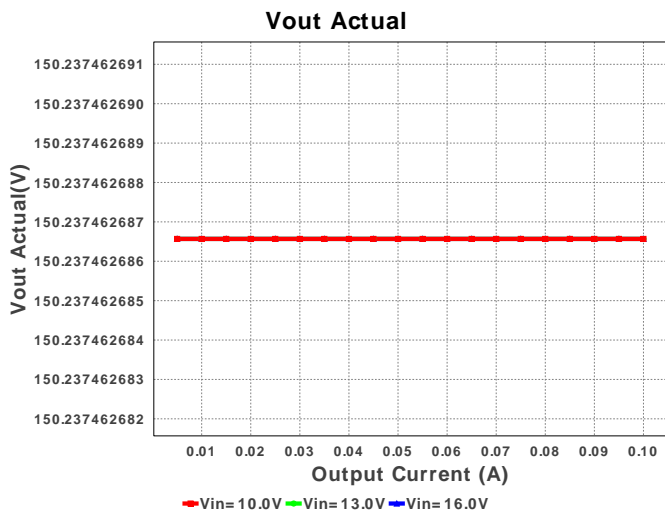

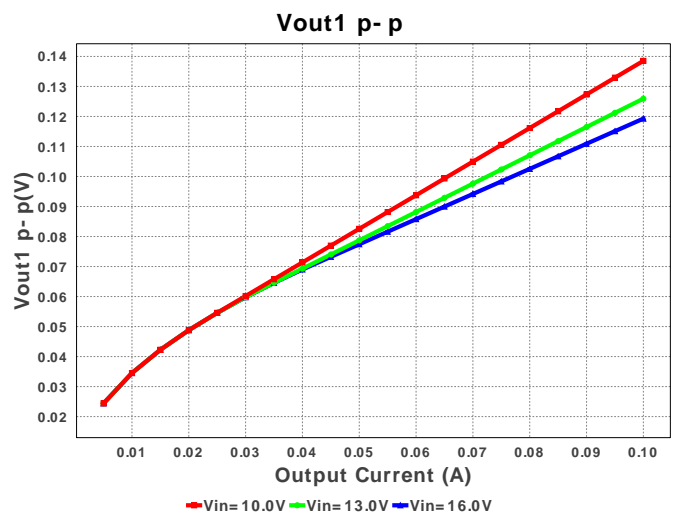
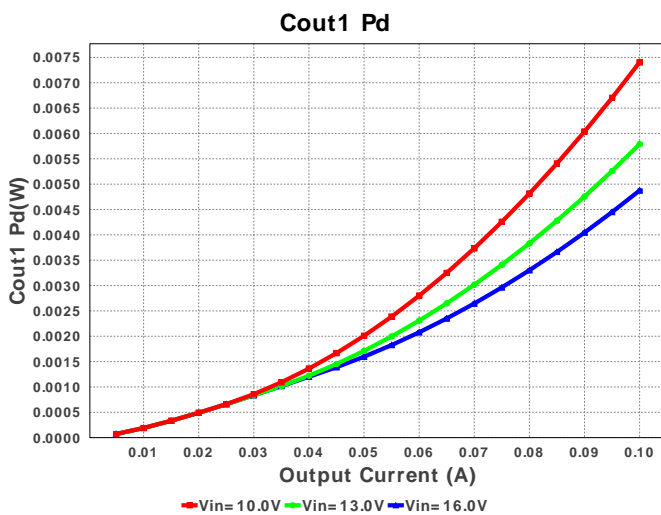
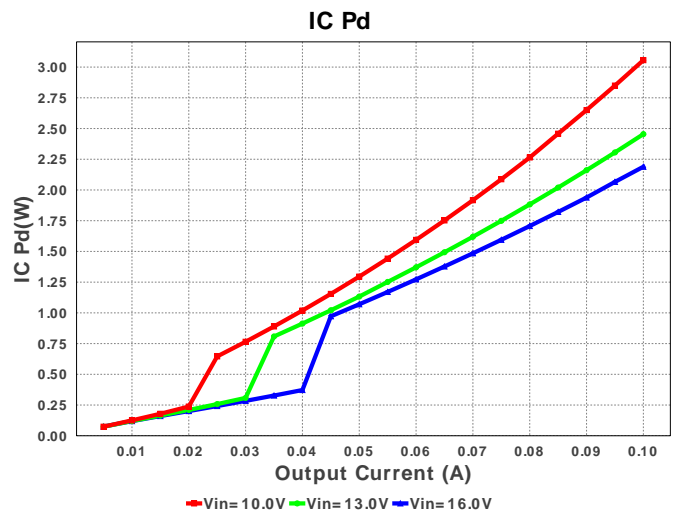
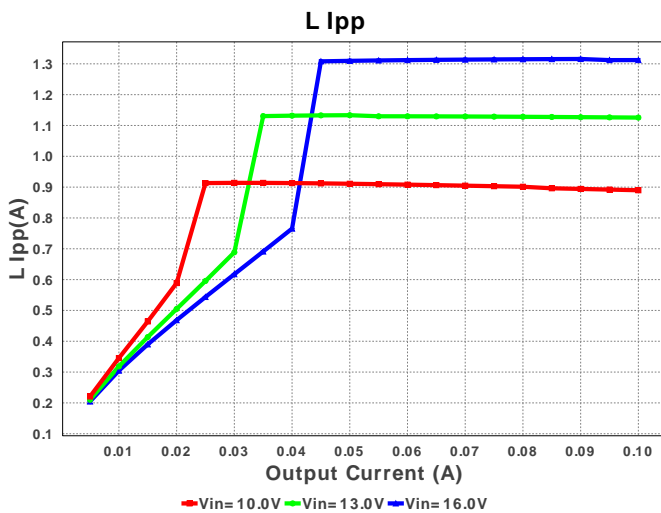
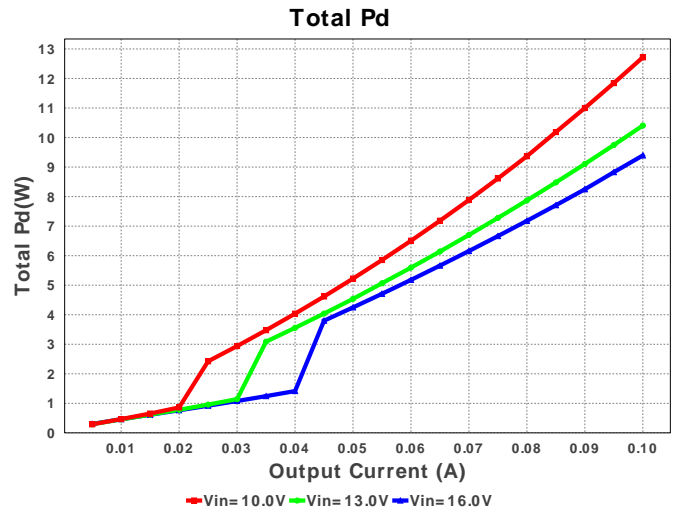
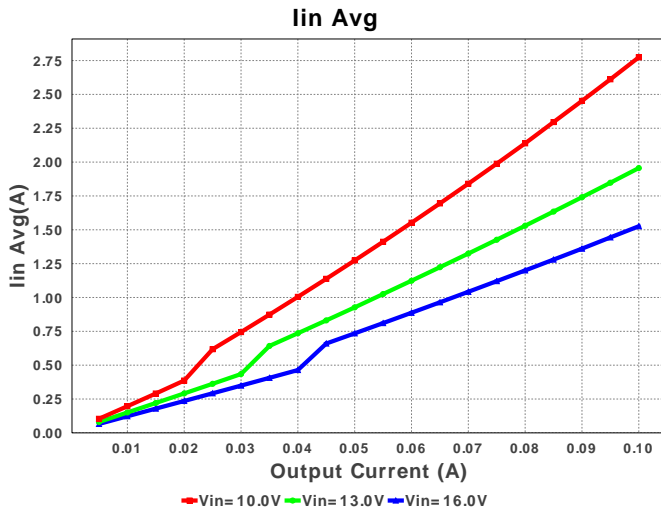

Operating Values

#	Name	Value	Category	Description
1.	Cin IRMS	1.243 A	Current	Input capacitor RMS ripple current
2.	Cout1 IRMS	136.235 mA	Current	Output capacitor1 RMS ripple current
3.	IC Ipk	4.121 A	Current	Peak switch current
4.	Iin Avg	2.786 A	Current	Average input current
5.	L Ipp	883.65 mA	Current	Peak-to-peak inductor ripple current
6.	BOM Count	13	General	Total Design BOM count
7.	FootPrint	1.403 k mm ²	General	Total Foot Print Area of BOM components
8.	Frequency	151.071 kHz	General	Switching frequency
9.	IC Tolerance	22.0 mV	General	IC Feedback Tolerance
10.	Mode	CCM	General	Conduction Mode
11.	Pout	15.024 W	General	Total output power

#	Name	Value	Category	Description
12.	Total BOM	\$0.0	General	Total BOM Cost
13.	Vout Actual	150.237 V	Op_Point	Vout Actual calculated based on selected voltage divider resistors
14.	Duty Cycle	75.541 %	Op_point	Duty cycle
15.	Efficiency	53.927 %	Op_point	Steady state efficiency
16.	IC Tj	87.711 degC	Op_point	IC junction temperature
17.	ICThetaJA	18.748 degC/W	Op_point	IC junction-to-ambient thermal resistance
18.	IOUT_OP	100.0 mA	Op_point	Iout operating point
19.	VIN_OP	10.0 V	Op_point	Vin operating point
20.	Vout1 OP	150.237 V	Op_point	Operational Voltage 1
21.	Vout1 p-p	138.604 mV	Op_point	Peak-to-peak output1 ripple voltage
22.	Cin Pd	37.101 mW	Power	Input capacitor power dissipation
23.	Cout1 Pd	7.424 mW	Power	Output capacitor1 power dissipation
24.	Cout1 Pd	7.424 mW	Power	Output capacitor1 power dissipation
25.	Diode1 Pd	6.657 W	Power	Diode1 power dissipation
26.	IC Pd	3.078 W	Power	IC power dissipation
27.	Total Pd	12.835 W	Power	Total Power Dissipation
28.	Xformer Pd	1.269 W	Power	Transformer power dissipation
29.	Zener Pd	1.74 W	Power	Zener power dissipation
30.	Vout Tolerance	3.828 %		Vout Tolerance based on IC Tolerance (no load) and voltage divider resistors if applicable

Design Inputs

#	Name	Value	Description
1.	Iout	100.0 m	Maximum Output Current
2.	VinMax	16.0	Maximum input voltage
3.	VinMin	10.0	Minimum input voltage
4.	Vout	150.0	Output Voltage
5.	base_pn	LM2588	Base Product Number
6.	source	DC	Input Source Type
7.	Ta	30.0	Ambient temperature

Design Assistance

1. **LM2588** Product Folder : <http://www.ti.com/product/LM2588> : contains the data sheet and other resources.

Texas Instruments' WEBENCH simulation tools attempt to recreate the performance of a substantially equivalent physical implementation of the design. Simulations are created using Texas Instruments' published specifications as well as the published specifications of other device manufacturers. While Texas Instruments does update this information periodically, this information may not be current at the time the simulation is built. Texas Instruments does not warrant the accuracy or completeness of the specifications or any information contained therein. Texas Instruments does not warrant that any designs or recommended parts will meet the specifications you entered, will be suitable for your application or fit for any particular purpose, or will operate as shown in the simulation in a physical implementation. Texas Instruments does not warrant that the designs are production worthy.

You should completely validate and test your design implementation to confirm the system functionality for your application prior to production.

Use of Texas Instruments' WEBENCH simulation tools is subject to [Texas Instruments' Site Terms and Conditions of Use](#). Prototype boards based on WEBENCH created designs are provided AS IS without warranty of any kind for evaluation and testing purposes and are subject to the terms of the [Evaluation License Agreement](#).