

NOTE: DNI = DO NOT INSTALL

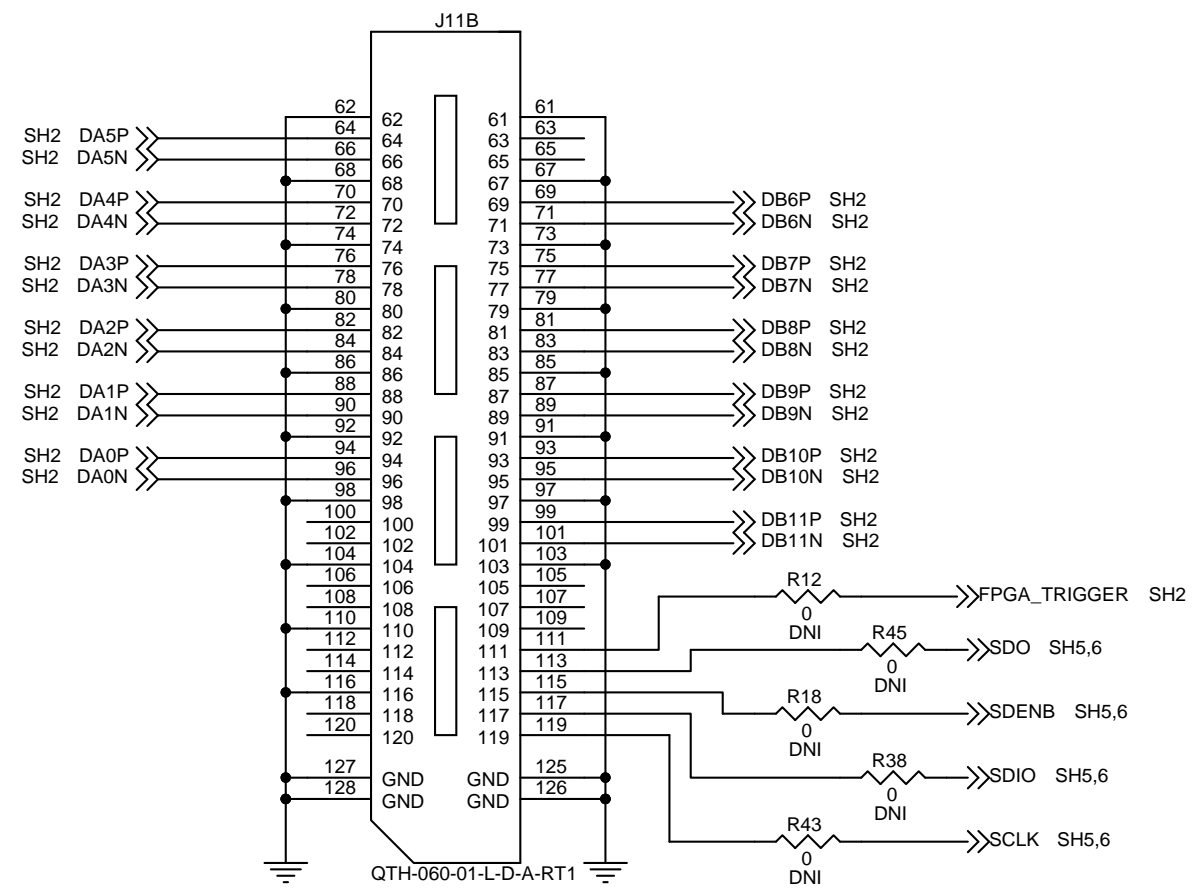

Title		
ADS540X & ADS54TOX EVM		
Size	Document Number	Rev
B	ANALOG IN	A
Date:	Thursday, January 17, 2013	Sheet 1 of 6

Engineer: R PRENTICE
PCB Designer: JV SMITH

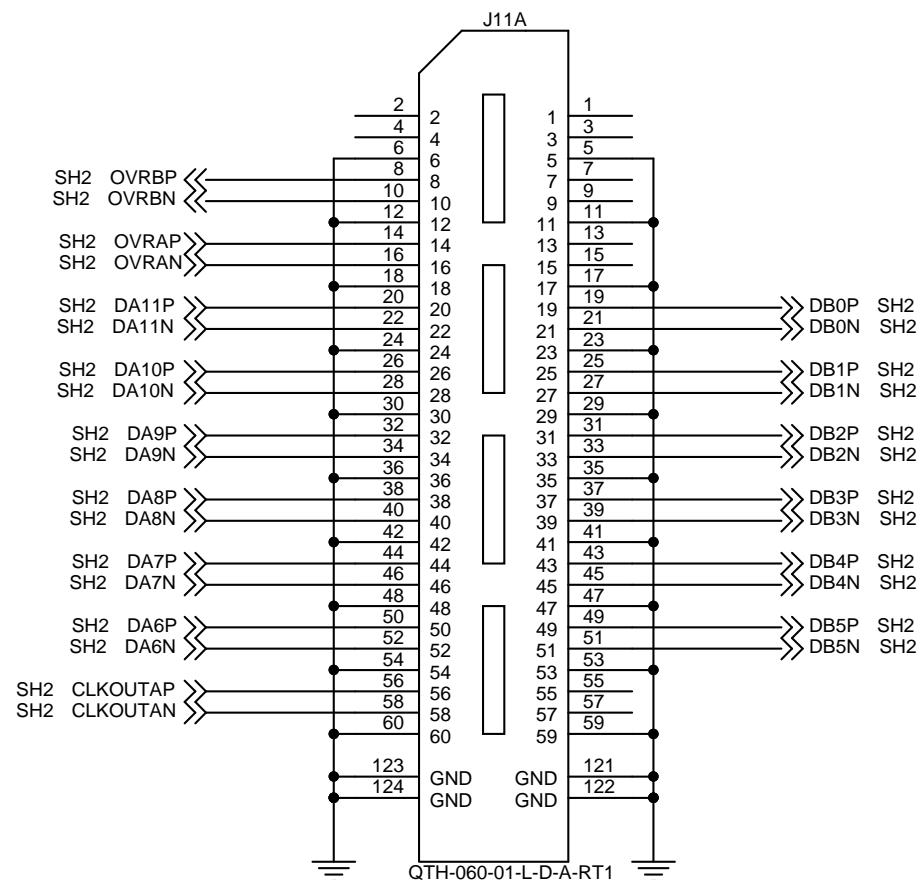

Title		
ADS540X & ADS54TOX EVM		
Size	Document Number	Rev
B	I/F CONNECTOR	A
Date:	Thursday, January 17, 2013	Sheet 3 of 6

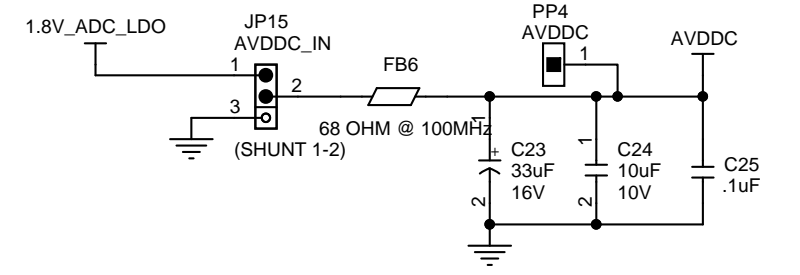
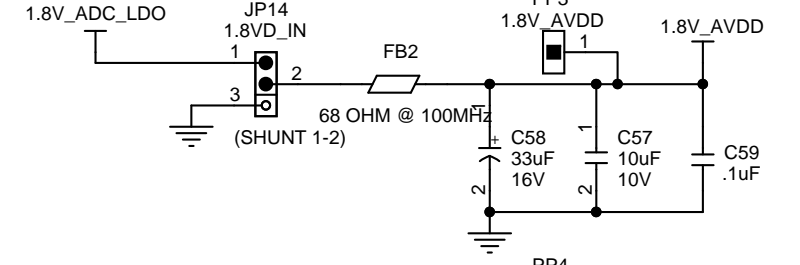
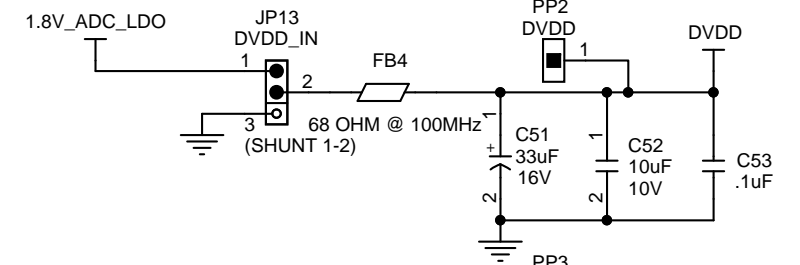
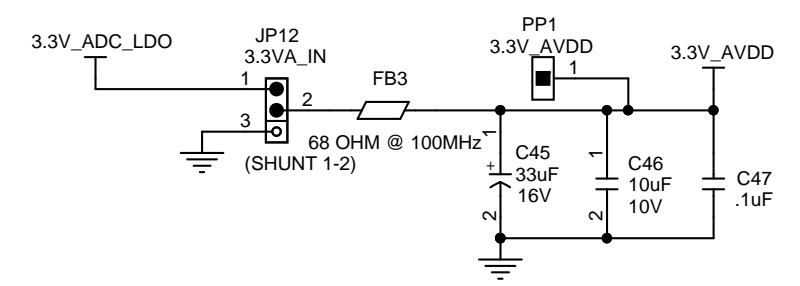
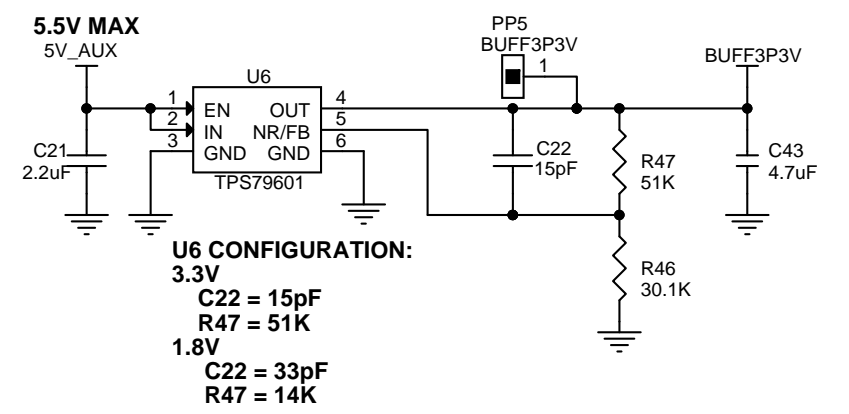
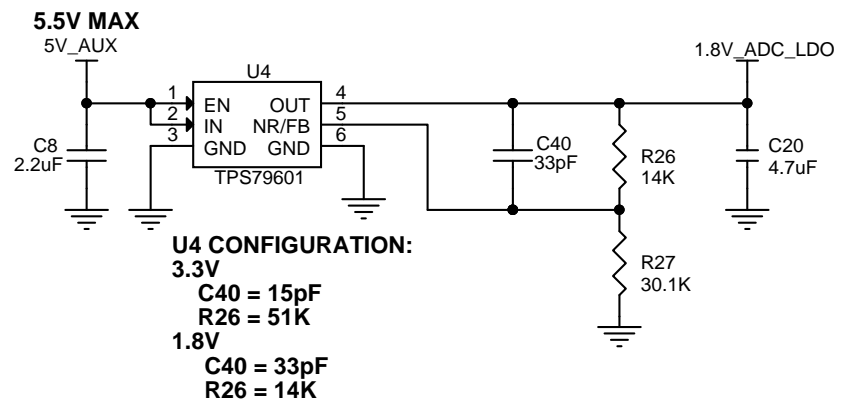
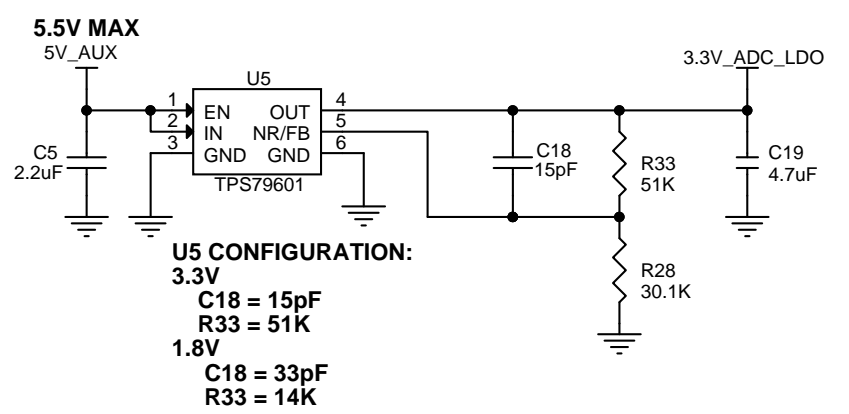
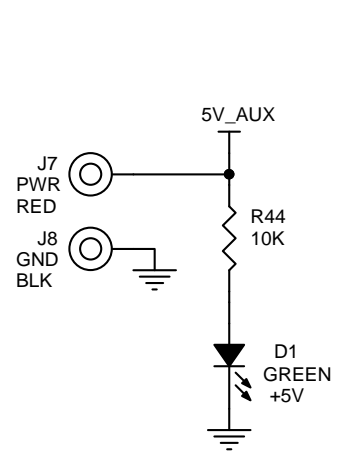

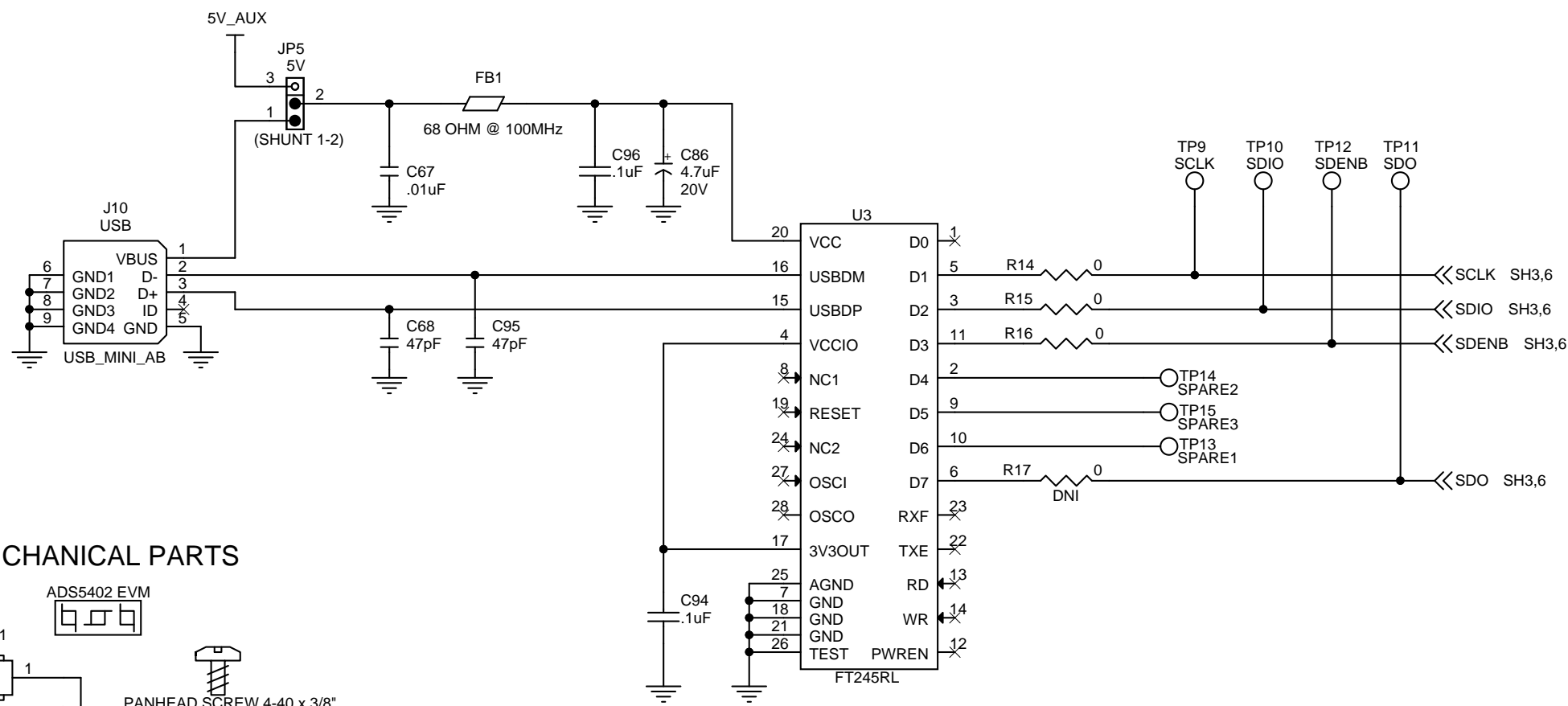
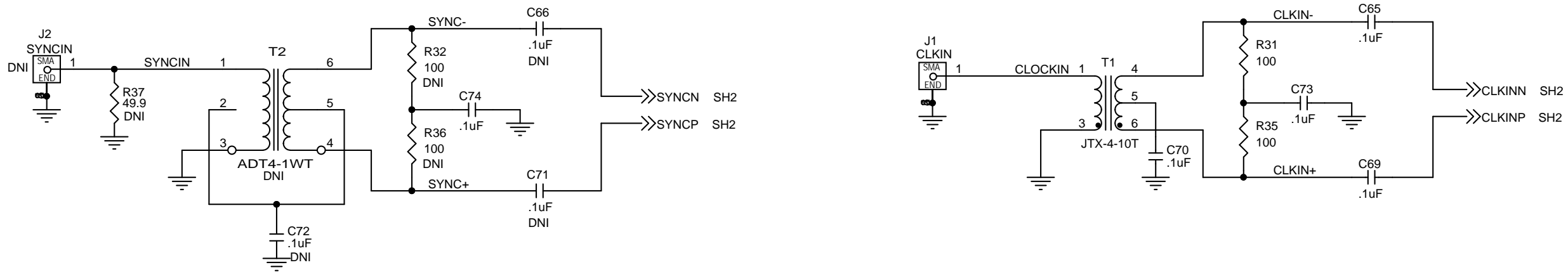

MECHANICAL PARTS

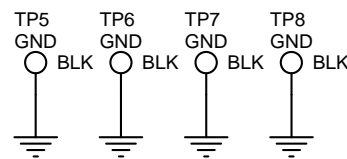
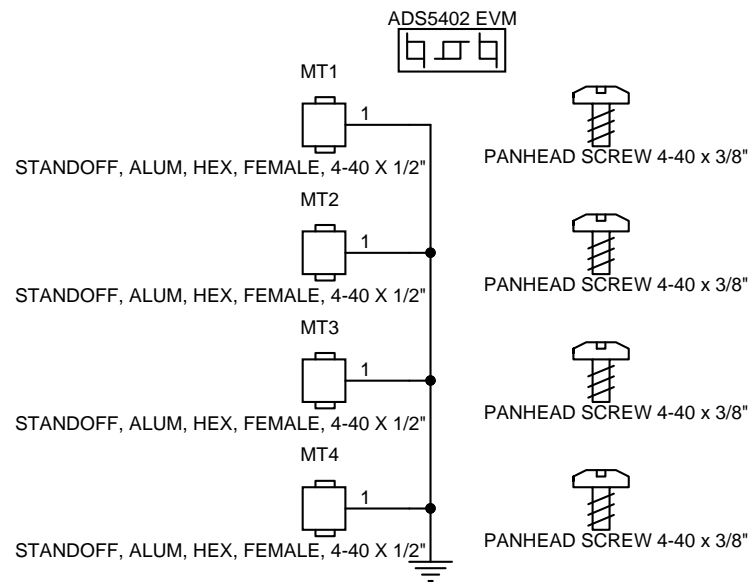

TEXAS INSTRUMENTS

Title: **ADS540X & ADS54TOX EVM**

Size B	Document Number	Rev A
Date: Thursday, January 17, 2013	Sheet 5 of 6	

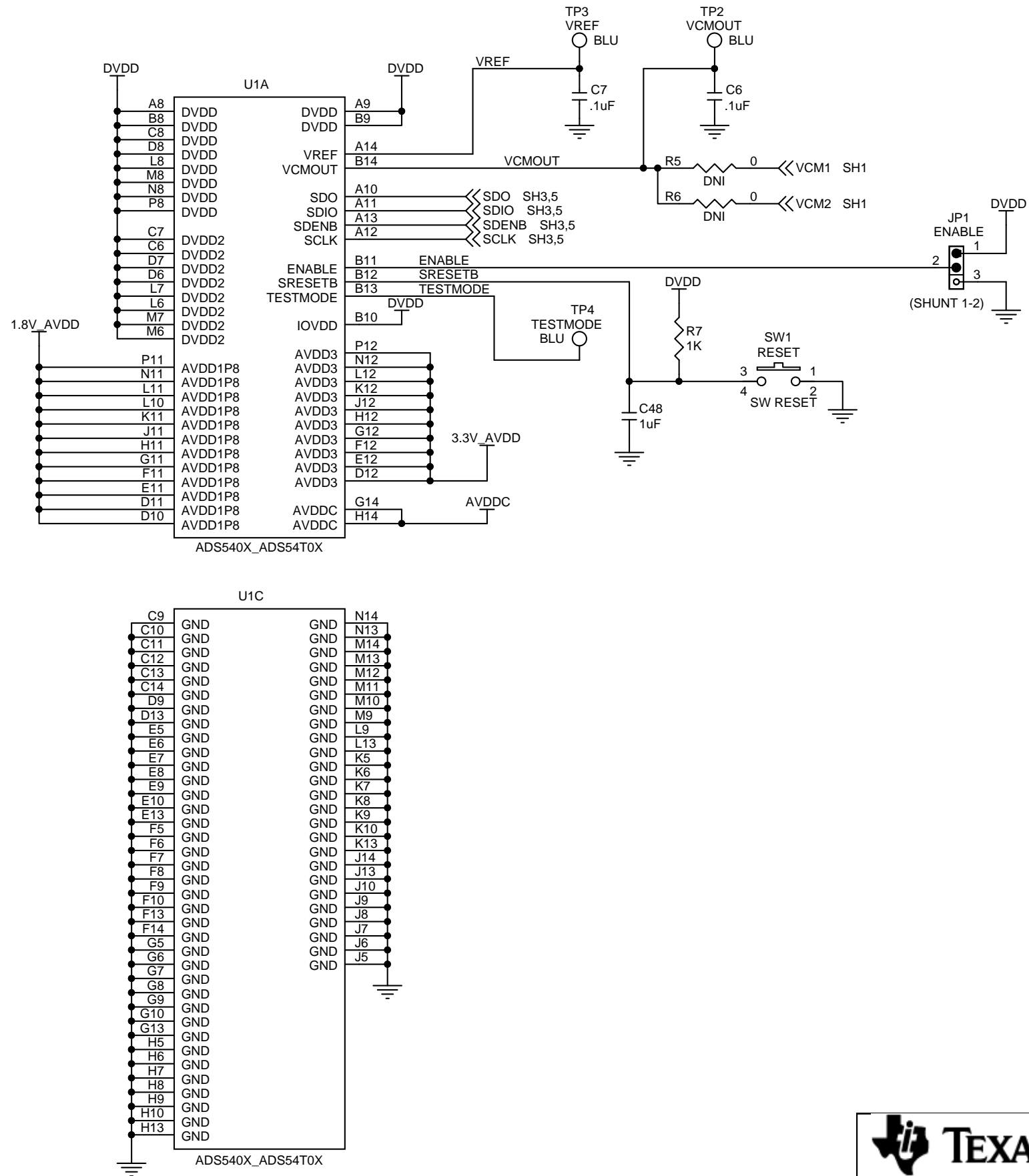
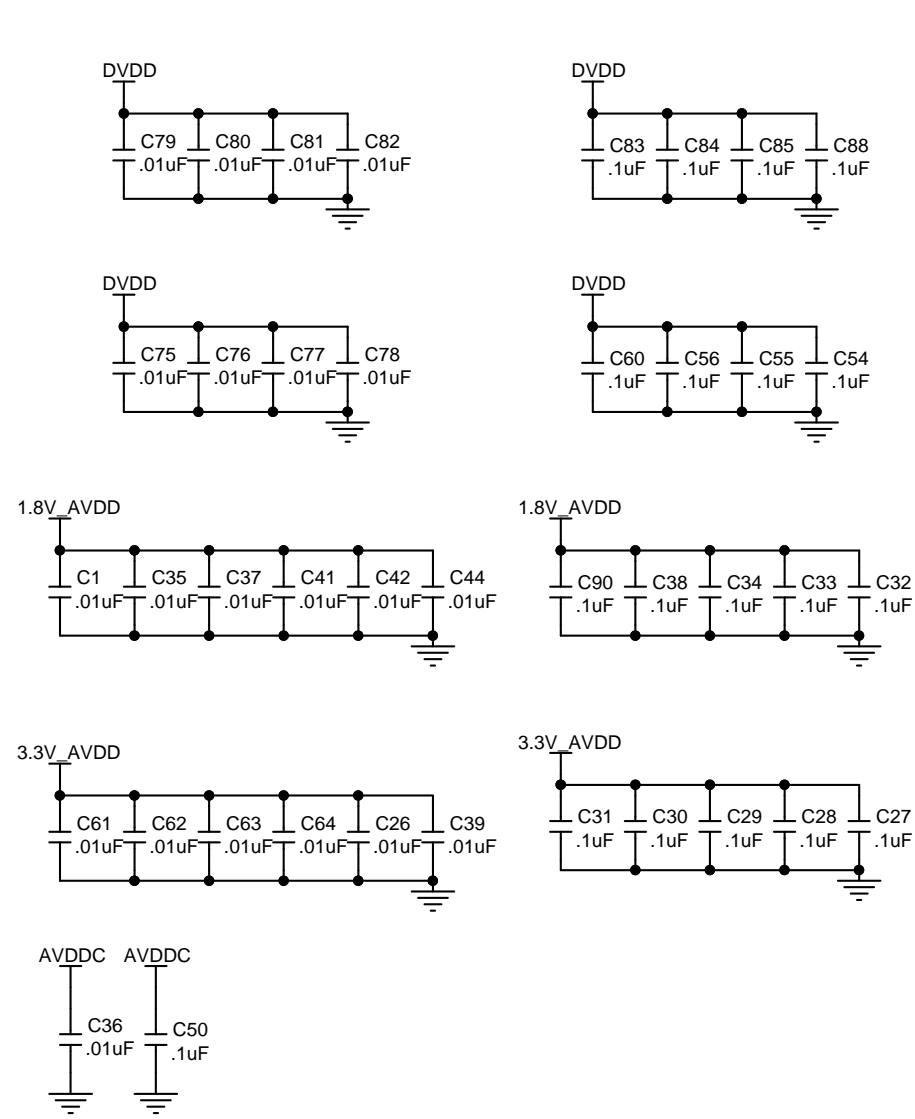

TEXAS INSTRUMENTS
 12000 TI Boulevard Dallas, Texas 75243

Title: **ADS540X & ADS54T0X EVM**

Size: **B** Document Number: **ADC PWR** Rev: **A**

Date: Thursday, January 17, 2013 Sheet 6 of 6