



亞信電子
YAXIN ELECTRONIC TECH

SPECIFICATION FOR APPROVAL

CUSTOMER: K115

DESCRIPTION: 1000W COMMON MODE CHOKE

YAXIN PART NO: YXS80466T Rev:A

CUSTOMER PN: COMMON MODE CHOKE Rev:A

CHOP&SIGNATURES:(YAXIN PREPARED)		
MADE BY	CHECKED BY	APPROVED BY
Yue Jun	Yue Jun	Owen

CUSTOMER APPROVAL



ISO9001:2008



ISO14001:2004



IATF16949:2016



File no:E342506

The environmental requirements



**REACH
SVHC**

**YAXIN
DESGI**

APPROVAL SAMPLE SUBMIT									
PROTOTYPE SAMPLE			DV SAMPLE			PV SAMPLE			NOTE
QTY'S(PCS)	DATE	APPROVED	QTY'S(PCS)	DATE	APPROVED	QTY'S(PCS)	DATE	APPROVED	

CONTACT:

E-mail:yaxin.ella@yx-magnetics.net

TEL:+86-755-33691163 ext 8032

Address:Innovation Park,GenYu Road,GuangMing New District,Shenzhen City,Guangdong Province,China

SPECIFICATION

MECHANICAL SPECIFICATION: (mm)

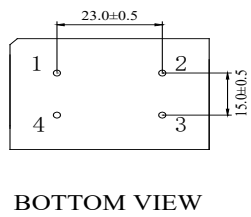
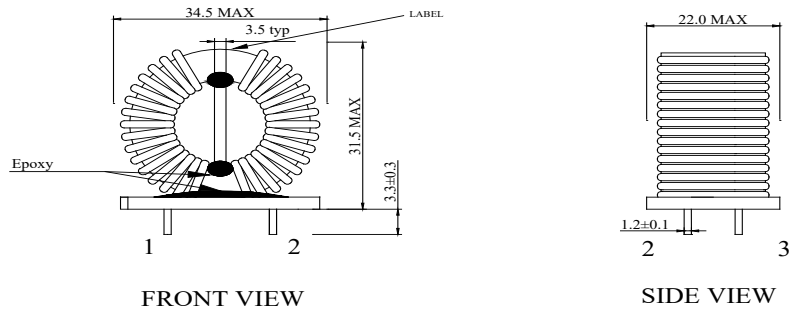

LABEL

1000W COMMON MODE CHOKE
YAXIN YYWW X

REV:版本

WW:周 (1: 01; 2: 02...)

YY:年 (2019: 19; 2020: 20...)

NOTES:

1. Apply the epoxy to these points to fix the base and core.

SPECIFICATION

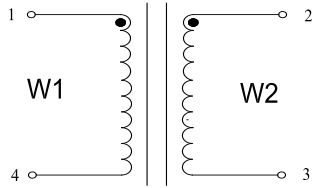
SCHEMATIC:

● indicate winding start

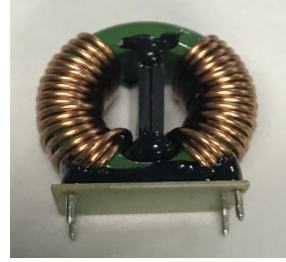
WINDING STACK UP:

WINDING DIAGRAM

WINDING	WIRE	S-F	TURNS(Ts)	TAPE	REMARK
W1	Φ1.20mm*1C 2UEW-F	1-4	19Ts Ref		Turns are adjustable to meet electrical requirement
W2	Φ1.20mm*1C 2UEW-F	2-3	19Ts Ref		

NOTES:

ELECTRICAL CHARACTERISTIC: AT 25°C

Loc.	PARAMETER	SPECIFICATION LIMITS	MEASURING CONDITION	MEASURING EQUIPMENT
a	L(1-4)=(2-3)	2.8~5.6mH	10KHz/ 0.1V	HP4284A OR EQUIV
	LK(1-4) Shorted Pin 2.3	110 MAX	10KHz/ 1.0V	HP4284A OR EQUIV
b	DCR(1-4)=(2-3)	20mΩ Max		CHROMA 16502 OR EQUIV
c	INSULATION RESISTANCE (Winding-Core)	100 M ohm Min	at 500 VDC	CHROMA 19073 OR EQUIV
	INSULATION RESISTANCE (Winding-Winding)	100 M ohm Min	at 500 VDC	CHROMA 19073 OR EQUIV
d	HI-POT(Winding-CORE)	600V/AC	AT 1 seconds,1mA,60HZ	CHROMA 19073 OR EQUIV
	HI-POT(Winding-Winding)	1800V/AC	AT 1 seconds,1mA,60HZ	CHROMA 19073 OR EQUIV
e	LAYER SHORT TEST	1200V/AC	AREA SIZE:±10% (Ref)	CHROMA 19305 OR EQUIV

SPECIFICATION

5. MATERIAL LIST(All RoHS Compliant):

NO.	NAME	MATERIAL	RATING	UL NO.	MANUFACTURER
1	FERRITE CORE	T29*19*16C 3E27	NA	NA	FERROXCUBE
		T29*19*16C R7K	NA	NA	DMEGC MAGNETICS CO.,LTD
		T29*19*16C TS7	NA	NA	TDG HOLDING CO., LTD.
		T29*19*16C A07	NA	NA	ACME ELECTRONICS CORPORATION
2	FERRITE CORE	18.4*16*3.5mm JC1	NA	NA	JIACI (ZHUHAI) ELECTRONICS CO LTD
3	BASE	FR-1 & FR-4	130℃	E123995	KINGBOARD LAMINATES LTD
4	WIRE	Xuew@/155	155℃	E334055	SHENZHEN JIAZHENGXIN INDUSTRIAL CO LTD
		Xuew-F@/155	155℃	E339217	ZHUHAI WEIHAN WIRE CO LTD
5	EPOXY	3300A-1/B-1	90℃	E218090	DONGGUAN EATTO ELECTRONIC MATERIAL CO LTD
6	VARNISH	V1630FS	130℃	E75225	ELANTAS ELECTRICAL INSULATION ELANTAS PDG INC
		DA-700-*	130℃	E347463	HUIZHOU QIANG DA ELECTRONICS INDUSTRY CO LTD
		TVB-2180T	155℃	E83702	KYOCERA CHEMICAL CORP



亞信電子
YAXIN ELECTRONIC TECH

亞信发展有限公司

YAXIN DEVELOPMENT CO LIMITED

Customer P/N.

COMMON MODE
CHOKE

Customer Rev.

A

Yaxin P/N.

YXS80466T