

Copying this document, giving it to others and the use or communication of the contents thereof without express authority, are forbidden.
 All rights are reserved for the payment of damages or for a patent or the registration of a utility model for design.
 All rights reserved.

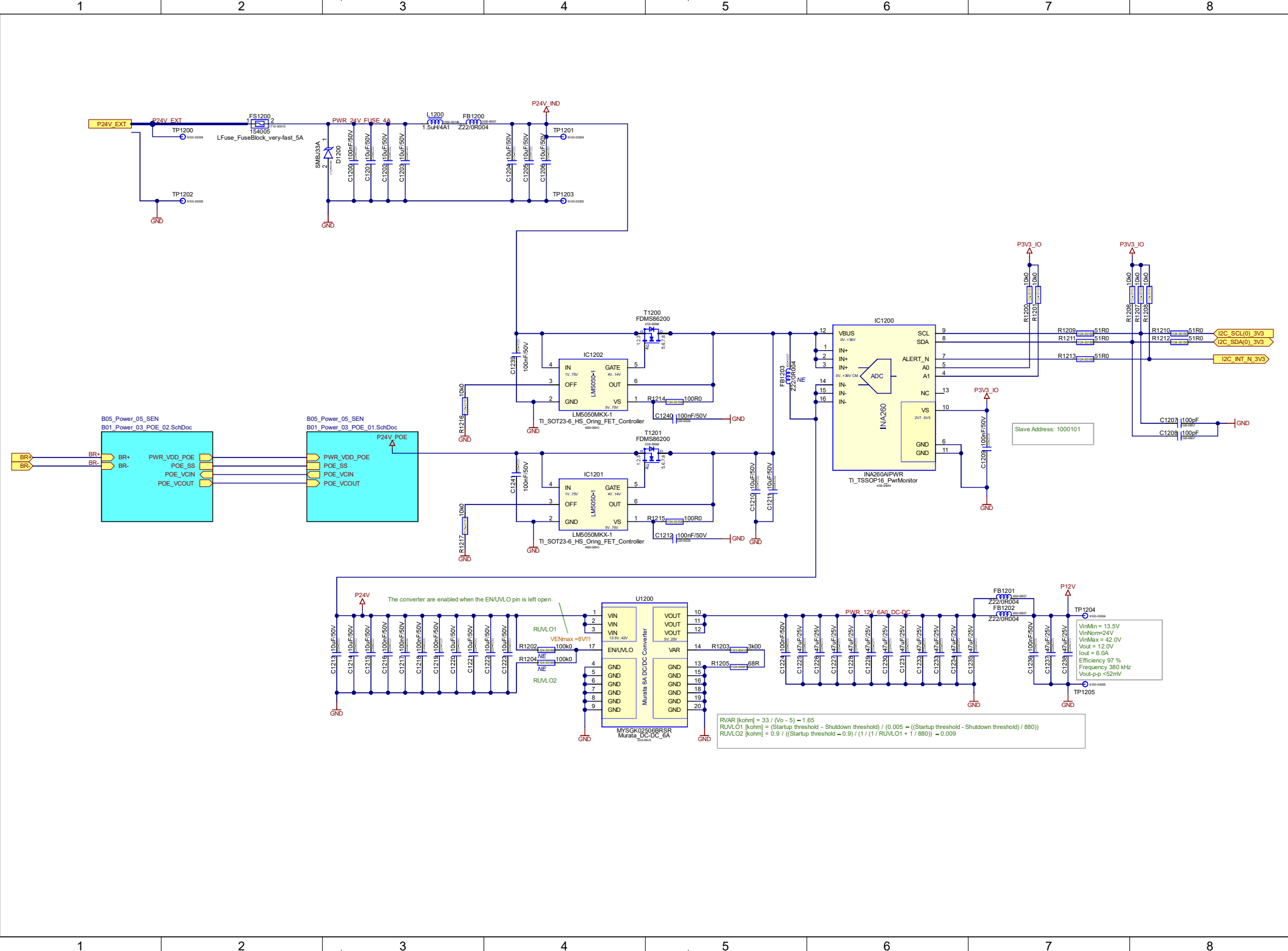

Copying this document, giving it to others and the use or communication of the contents thereof without express authority, are forbidden.
All rights are reserved for the payment of damages or for the registration of a patent or the registration of a utility model for design.

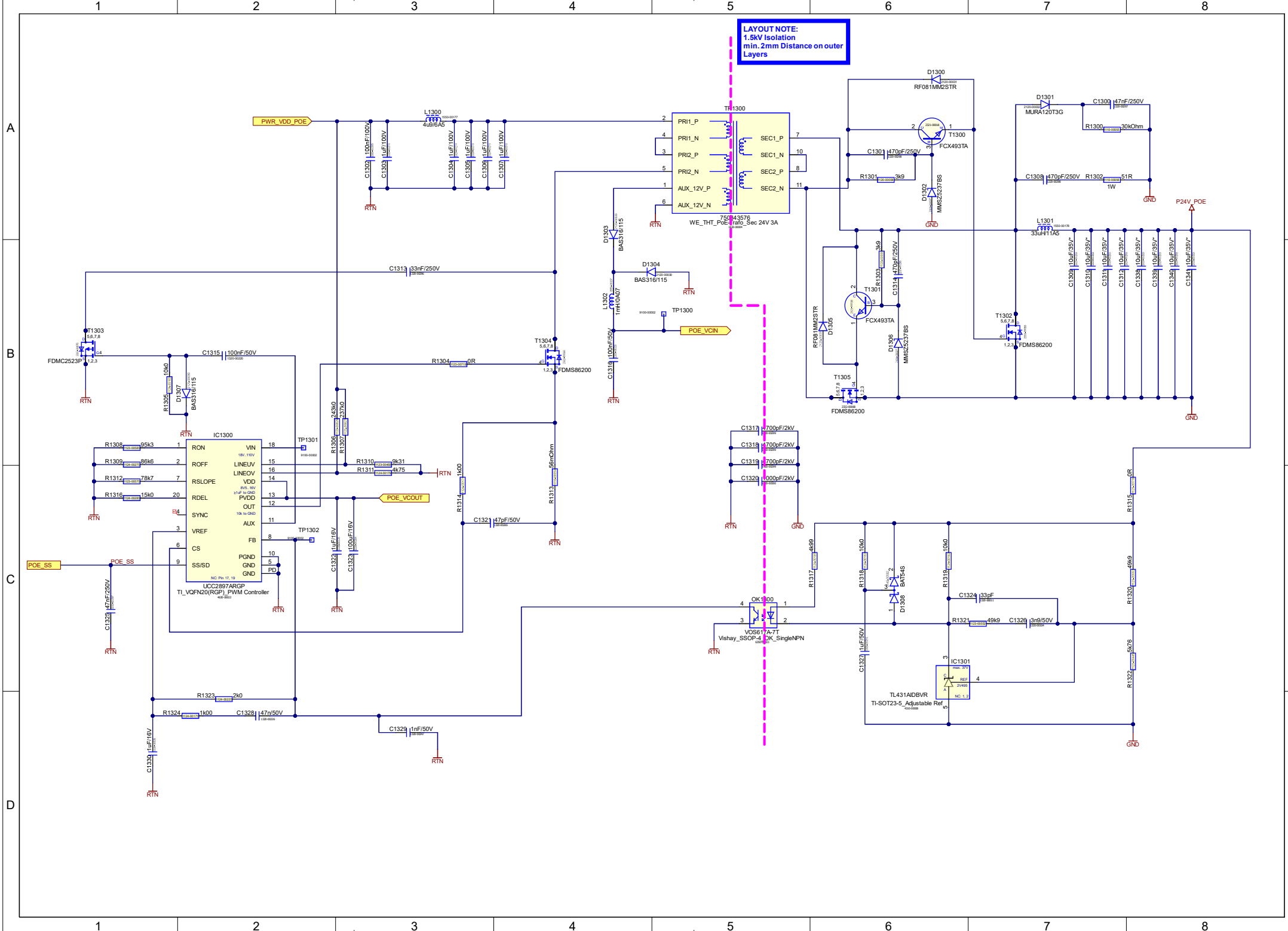

A
B
C
D

A
B
C
D

1 2 3 4 5 6 7 8

1 2 3 4 5 6 7 8

Copying this document, giving it to others and the use or communication of the contents thereof without express authority, are forbidden.
All rights are reserved for this patent or for any patent or for the registration of a utility model for design.

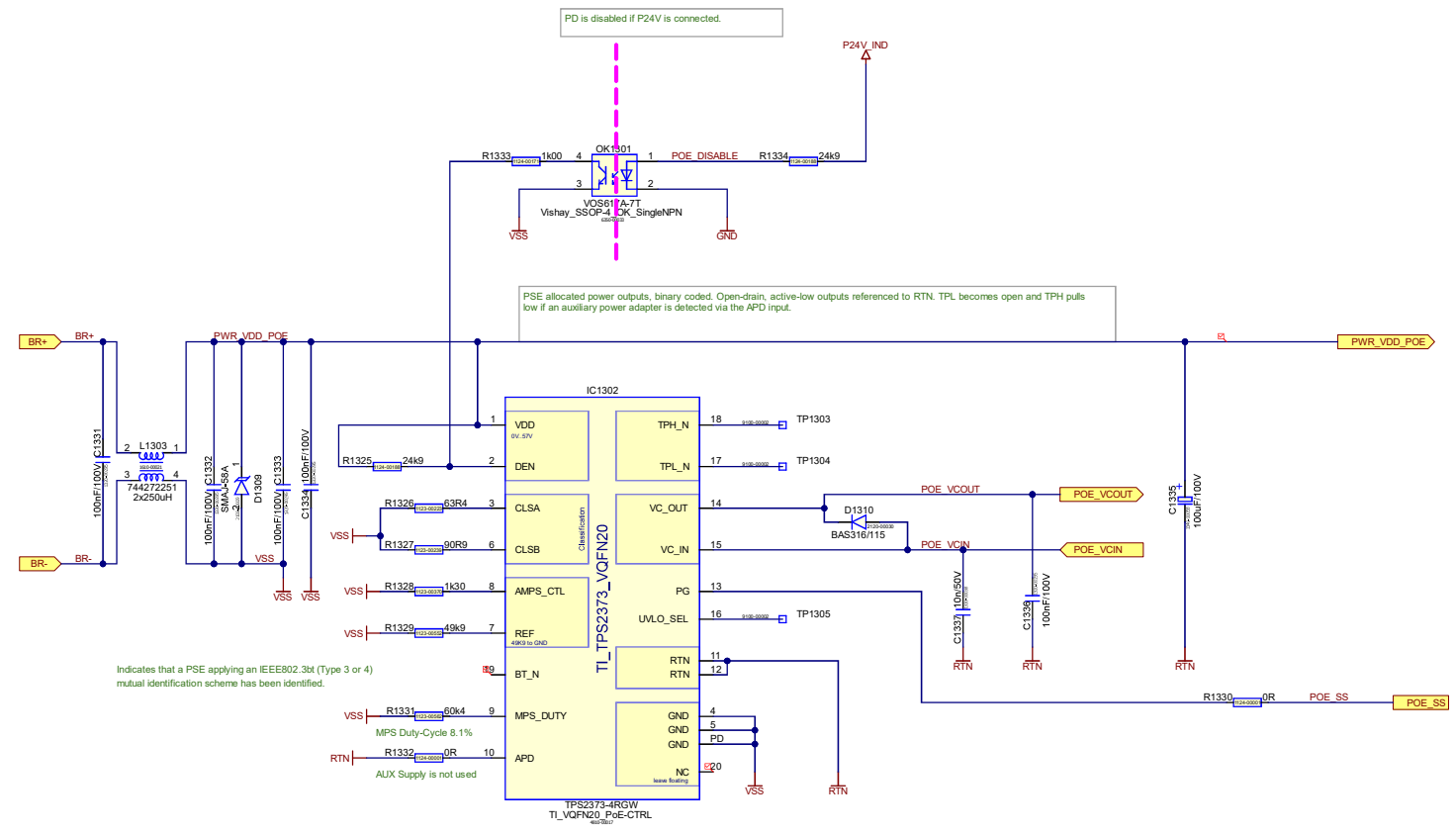

PD is disabled if P24V is connected.

PSE allocated power outputs, binary coded. Open-drain, active-low outputs referenced to RTN. TPL becomes open and TPH pulls low if an auxiliary power adapter is detected via the APD input.

Indicates that a PSE applying an IEEE802.3bt (Type 3 or 4) mutual identification scheme has been identified.

MPS Duty-Cycle 8.1%

ALX Supply is not used

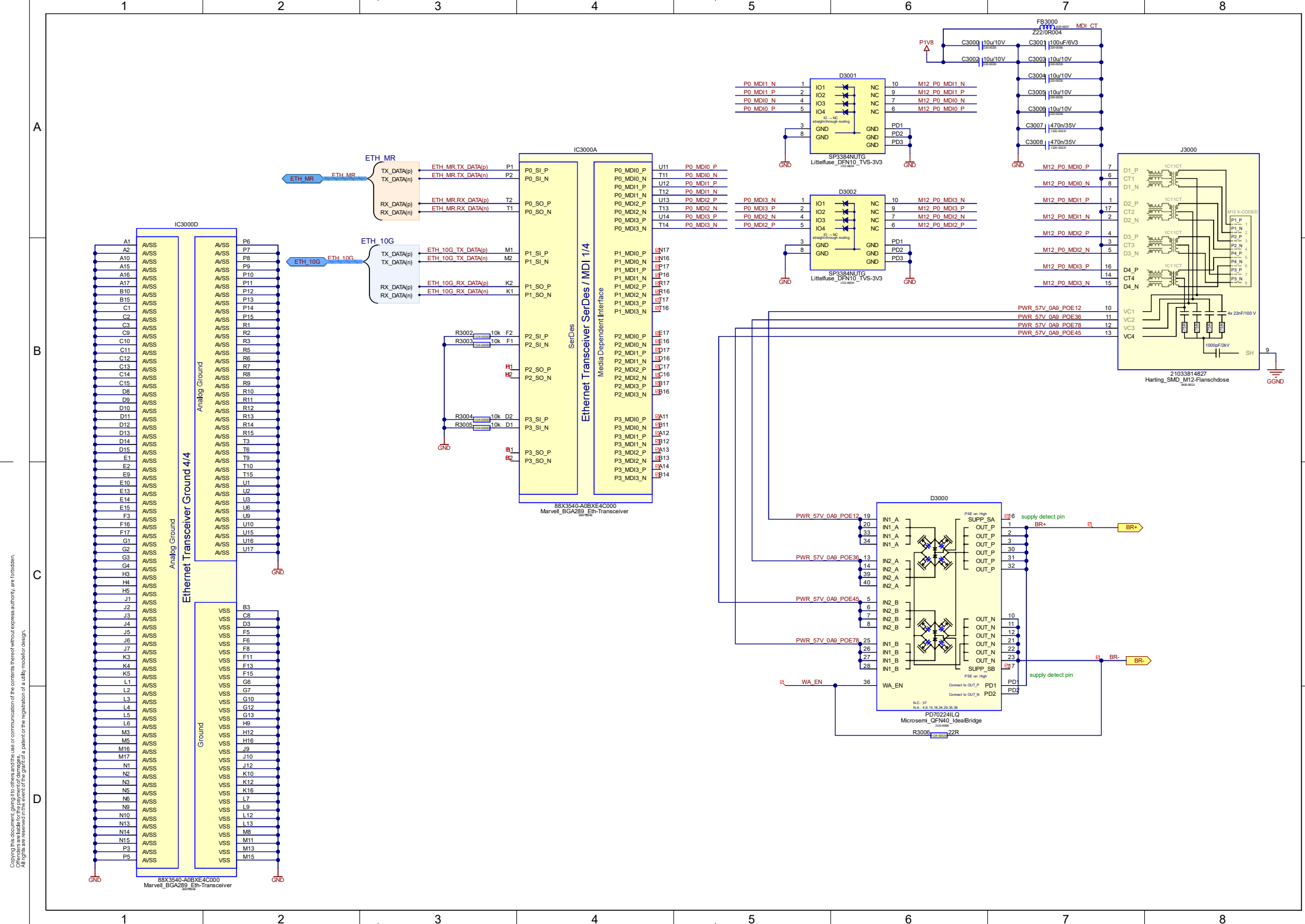

Copying this document, giving it to others and the use or communication of the contents thereof without express authority, are forbidden.
 All rights are reserved. No part of this document may be reproduced, stored in a retrieval system, or transmitted in any form or by any means, electronic, mechanical, photocopying, recording, or by any information storage and retrieval system, without the prior written permission of the copyright owner.