

# **User's Guide**

## **DS100KRxxx IBIS-AMI Model**

Version 4  
September 2014

The information and/or drawings set forth in this document and all rights in and to inventions disclosed herein and patents which might be granted thereon disclosing or employing the materials, methods, techniques, or apparatus described herein are the exclusive property of Texas Instruments. No disclosure of information or drawings shall be made to any other person or organization without the prior consent of Texas Instruments.

■ **Texas Instruments Confidential – NDA Restrictions**

## Table of Contents

<b>1</b>	<b>Document Revision History .....</b>	<b>3</b>
<b>2</b>	<b>Overview .....</b>	<b>4</b>
<b>3</b>	<b>Receiver Model Parameters .....</b>	<b>5</b>
<b>4</b>	<b>Transmitter Model Parameters .....</b>	<b>7</b>
<b>5</b>	<b>Model Usage Tips .....</b>	<b>9</b>
<b>6</b>	<b>Model Verification.....</b>	<b>10</b>
6.1	Receiver test #1 .....	10
6.2	Receiver test #2.....	11
6.3	Receiver test #3.....	12
6.4	Transmitter test #1 .....	13
6.5	Full channel test #1 .....	14
6.6	Full channel test #2.....	16
6.7	Statistical versus Time Domain: RX test .....	18
6.8	Statistical versus Time Domain: Full Link test .....	19
6.9	Comparison between Agilent ADS and SiSoft QCD .....	20

## 1 Document Revision History

<b>Revision</b>	<b>Comment</b>	<b>Date</b>
1	<ul style="list-style-type: none"><li>• Initial creation of User's Guide.</li></ul>	23-Feb-2012
2	<ul style="list-style-type: none"><li>• Update to include LTI (statistical) mode.</li></ul>	11-March-2014
3	<ul style="list-style-type: none"><li>• Update to include s-parameter based termination.</li></ul>	02-April-2014
4	<ul style="list-style-type: none"><li>• Update to model-specific parameter default values.</li><li>• Updated for IBIS version 6.0.</li><li>• Updated package models.</li></ul>	24-Sep-2014

## 2 Overview

This document is a User's Guide for the DS100KRxxx Buffer Repeater. Table 1 below lists pertinent information related to the delivered model.

**Table 1: Model information**

Item	Value/Comment
TI device models included	<a href="#">DS100KR210</a> , <a href="#">DS100KR401</a> , and <a href="#">DS100KR800</a> Buffer Repeaters
IBIS version	Compliant to <a href="#">IBIS version 6.0</a> .
Supported platforms	<ul style="list-style-type: none"> <li>• 32-bit Windows</li> <li>• 64-bit Windows</li> <li>• 64-bit Linux</li> </ul>
Release package files	<pre> TI_DS100KRxxx_IBIS_AMI_vN   +-- Example_Projects           +-- TI_DS100KRxxx_ADS_Project_Quick_Guide.pdf     +-- Agilent_ADS_2013.06.7zads   +-- Model           +-- TI_DS100KRxxx_IBIS_AMI_User_Guide.pdf     +-- DS100KRXXX.ibs     +-- DS100KRxxx_Tx_03_2014.ami     +-- DS100KRxxx_Rx_03_2014.ami     +-- DS100KRxxx_Tx_03_2014.dll     +-- DS100KRxxx_Rx_03_2014.dll     +-- DS100KRxxx_Tx_03_2014_x64.dll     +-- DS100KRxxx_Rx_03_2014_x64.dll     +-- DS100KRxxx_Tx_03_2014_x64.s0     +-- DS100KRxxx_Rx_03_2014_x64.so     +-- WQFN54_rx.s4p     +-- WQFN54_tx.s4p                     </pre>

### 3 Receiver Model Parameters

The DS100KRxxx receiver model includes the following model-specific parameters:

1. **EQ\_Level:** This parameter sets the Repeater's input equalization setting. Refer to Table 2 of the device datasheet (copied below for convenience).

Model EQ_Level setting	Table 2. Equalizer Settings							
	Level	EQA1 EQB1	EQA0 EQB0	EQ – 8 bits [7:0]	dB at 1.0 GHz	dB at 3.0 GHz	dB at 5.0 GHz	Suggested Use
0	1	0	0	0000 0000 = 0x00	1.7	4.2	5.3	FR4 < 5 inch trace
1	2	0	R	0000 0001 = 0x01	2.8	6.6	8.7	FR4 5 inch 5–mil trace
2	3	0	Float	0000 0010 = 0x02	4.1	8.6	10.6	FR4 5 inch 4–mil trace
3	4	0	1	0000 0011 = 0x03	5.1	9.8	11.7	FR4 10 inch 5–mil trace
4	5	R	0	0000 0111 = 0x07	6.2	12.4	15.6	FR4 10 inch 4–mil trace
5	6	R	R	0001 0101 = 0x15	5.1	12.0	16.6	FR4 15 inch 4–mil trace
6	7	R	Float	0000 1011 = 0x0B	7.7	15.0	18.3	FR4 20 inch 4–mil trace
7	8	R	1	0000 1111 = 0x0F	8.8	16.5	19.7	FR4 25 to 30 inch 4–mil trace
8	9	Float	0	0101 0101 = 0x55	6.3	14.8	20.3	FR4 30 inch 4–mil trace
9	10	Float	R	0001 1111 = 0x1F	9.9	19.2	23.6	FR4 35 inch 4–mil trace
10	11	Float	Float	0010 1111 = 0x2F	11.3	21.7	25.8	10m, 30awg cable
11	12	Float	1	0011 1111 = 0x3F	12.4	23.2	27.0	10m – 12m cable
12	13	1	0	1010 1010 = 0xAA	11.9	24.1	29.1	
13	14	1	R	0111 1111 = 0x7F	13.6	26.0	30.7	
14	15	1	Float	1011 1111 = 0xBF	15.1	28.3	32.7	
15	16	1	1	1111 1111 = 0xFF	16.1	29.7	33.8	

2. **Limit:** This parameter puts the device into a limiting or non-limiting mode.

Model Limit setting	Description
0	In this mode the model operates in non-limiting mode. The peak-to-peak output voltage depends on the peak-to-peak input voltage. <i>This mode is required for applications which require link training (i.e. 8Gbps PCIe-Gen3 and 10.3125Gbps 10GBASE-KR).</i>
1	In this mode the model operates in limiting mode. An additional gain of 40dB is included and thus the output peak-to-peak voltage will only depend on the limiting amplitude and not the input peak-to-peak voltage. <i>This mode should be used for applications which do not require link training.</i>

3. **LTI\_mode:** This parameter determines whether the model's AMI\_Init() function returns a modified impulse response (for LTI simulations) or an unmodified impulse response (for non-LTI simulations). Regardless, the model has GetWave\_Exists=True and therefore all behavior (LTI and non-LTI) will be represented in time domain simulations.

**Note:** Not all EDA tools support pure statistical simulations for Redrivers/Retimers. Nevertheless, LTI mode can still be used.

<b>Model LTI_mode</b>	<b>Description</b>
0	Non-linear-time-invariant (non-LTI) mode. The AMI_Init() function does not modify the impulse response. <i>Not recommended.</i>
1 (default)	Linear time-invariant (LTI) mode. The AMI_Init() function does modify the impulse response based on the LTI approximation of the RX model's equalization. <i>Recommended.</i>

4. **Tstonefile:** On-die termination s-parameter file. This should not be modified by the user.
5. **Rx\_R:** Monitor for port termination impedance. Debug only.
6. **Supporting\_Files:** List of supporting files used by the model. This should not be modified by the user.

## 4 Transmitter Model Parameters

The DS100KRxxx transmitter model includes the following model-specific parameters:

1. **VOD\_Level:** This parameter sets the driver output voltage setting. There are eight VOD settings as shown in the table below. Note that in non-limiting mode (Limit=0), the output peak-to-peak amplitude will depend on the input peak-to-peak amplitude, so the output amplitude may not match the values shown in this table. In limiting model (Limit=1) the output peak-to-peak amplitude is directly controllable with the VOD\_Level setting.

Model VOD_Level setting	De-emphasis value
0	700 mVp-p
1	800 mVp-p
2	900 mVp-p
3	1000 mVp-p
4	1100 mVp-p
5	1200 mVp-p
6	1300 mVp-p
7	1400 mVp-p

2. **DE\_Level:** This parameter sets the driver de-emphasis level setting. There are eight de-emphasis settings as shown in the table below.

Model DE_Level setting	De-emphasis value
0	0 dB
1	-1.5 dB
2	-3.5 dB
3	-5.0 dB
4	-6.0 dB
5	-8.0 dB
6	-9.0 dB
7	-12.0 dB

3. **LTI\_mode:** This parameter determines whether the model's AMI\_Init() function returns a modified impulse response (for LTI simulations) or an unmodified impulse response (for non-LTI simulations). Regardless, the model has

GetWave\_Exists=True and therefore all behavior (LTI and non-LTI) will be represented in time domain simulations.

**Note:** Not all EDA tools support pure statistical simulations for Redrivers/Retimers. Nevertheless, LTI mode can still be used.

<b>Model LTI_mode</b>	<b>Description</b>
0	Non-linear-time-invariant (non-LTI) mode. The AMI_Init() function does not modify the impulse response. <i>Not recommended.</i>
1 (default)	Linear time-invariant (LTI) mode. The AMI_Init() function does modify the impulse response based on the LTI approximation of the TX model's equalization. <i>Recommended.</i>

4. **Gain\_debugonly:** This parameter should not be changed by the user. It is included for debug purposes only.
5. **Tstonefile:** On-die termination s-parameter file. This should not be modified by the user.
6. **Tx\_R:** Monitor for on-die supply series resistance. Debug only.
7. **Supporting\_Files:** List of supporting files used by the model. This should not be modified by the user.



## 5 Model Usage Tips

1. **How to set the samples per UI in the simulator.** Samples per UI should be chosen such that the sample time (UI divided by samples per UI) should be less than 10E-12 for accurate results. Typical recommended values for different bit rates are as follows:

Bit rate	Recommended samples per UI setting
≥ 1 Gbps	≥ 128 samples per UI
≥ 4 Gbps	≥ 64 samples per UI
≥ 8 Gbps	≥ 32 samples per UI

2. **Note on [Repeater Pin].** The [Repeater Pin] key word in the IBIS file is used to define the Rx input pin and Tx output pin pairs which form repeaters. At the time this document was written, this was not yet part of the official IBIS standard and hence the IBIS parser throws an 'Invalid Keyword' error upon encountering the [Repeater Pin] keyword. Please ignore this error as the model runs fine in most EDA tools (SiSoft QCD and Agilent ADS to name a few). In fact, the [Repeater Pin] definition is necessary to simulate 'Repeater' models in SiSoft QCD. If the model needs to be run in other tools which do not support this keyword (like Mentor Graphics Hyperlynx), the [Repeater Pin] definition can be deleted without any change in the functionality of the model.
3. **Note on IBIS Version 6.0.** Not all tools support IBIS Version 6.0 features such as AMI\_Version and Repeater\_Type reserved parameters. Check with your tool vendor. If the tool does not support IBIS version 6.0, it is safe to remove the AMI\_Version and Repeater\_Type parameters in the .ami files and change the [IBIS Ver] from 6.0 to 5.1.

## 6 Model Verification

To verify the functionality and accuracy of the model, comparisons were made between IBIS-AMI model simulations and Cadence transistor-level simulations at different data rates and for different channel media. In addition, comparisons between different IBIS-AMI simulators were made.

### 6.1 Receiver test #1

Signal source: 8.0 Gbps, 1 V peak-to-peak differential, 0 dB de-emphasis  
 Channel: 10 meter, 30 AWG copper cable  
 DS100KRxxx EQ\_Level: 10  
 DS100KRxxx Limit: 0  
 Measurement point: Receiver output

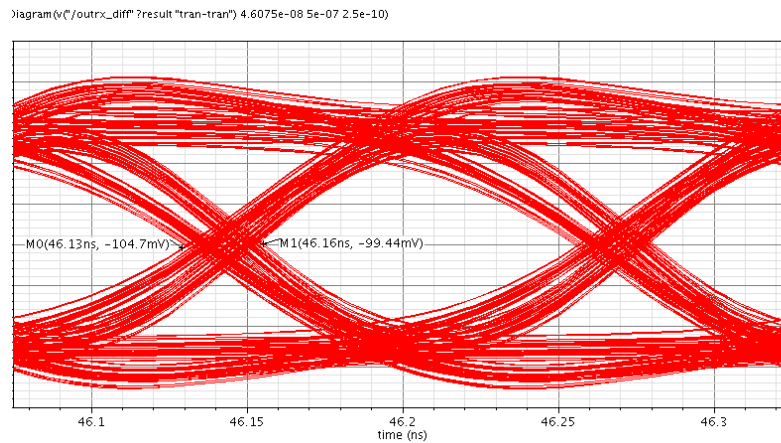
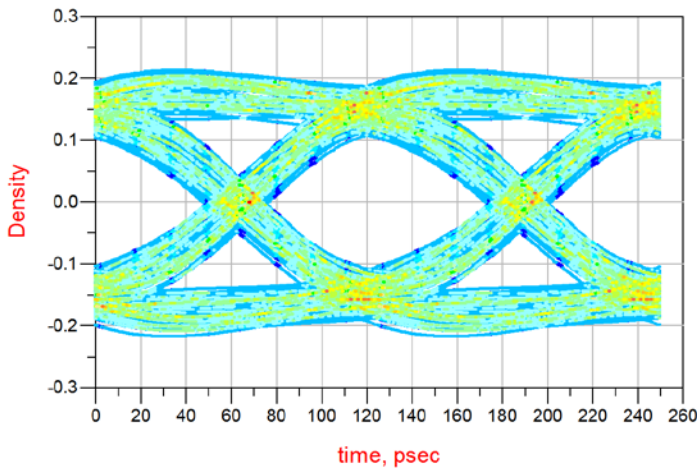


Figure 1: Cadence simulation (Jitter = 30 ps p-p)



measurement	Summary
Level1	0.150
Level0	-0.149
LevelMean	1.710E-4
Amplitude	0.299
Height	0.174
Width	9.625E-11
RiseTime	5.949E-11
FallTime	6.067E-11
JitterPP	2.875E-11
JitterRMS	7.109E-12
WidthAtBER	9.813E-11
HeightAtBER	0.214

Figure 2: IBIS-AMI simulation (Jitter = 29 ps p-p)

### 6.2 Receiver test #2

Signal source: 8.0 Gbps, 1 V peak-to-peak differential, 0 dB de-emphasis

Channel: 10 inches, 4 mil stripline

DS100KRxxx EQ\_Level: 6\*

DS100KRxxx Limit: 0

Measurement point: Receiver output

\*This test case is to deliberately show over-equalization, hence the misshapen eye.

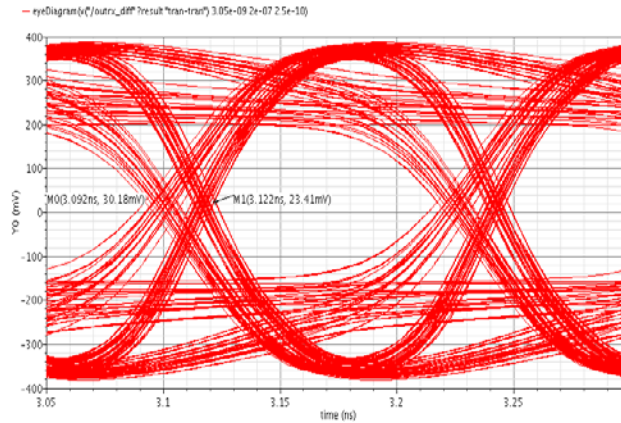
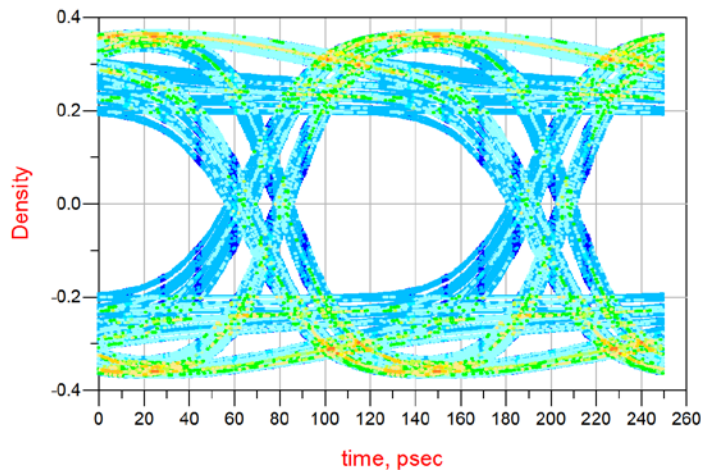


Figure 3: Cadence simulation (Jitter = 30 ps p-p)

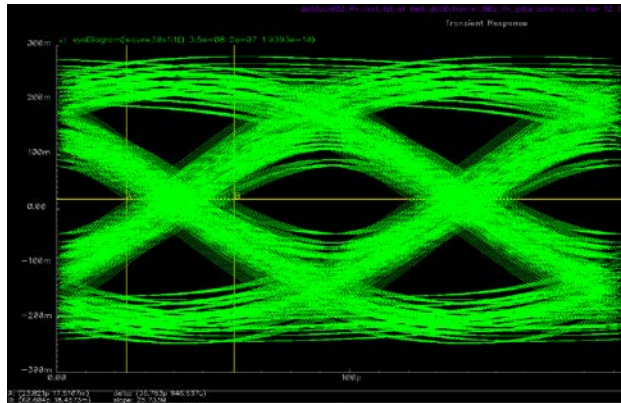


measurement	Summary
Level1	0.300
Level0	-0.301
LevelMean	-3.958E-4
Amplitude	0.600
Height	0.347
Width	9.625E-11
RiseTime	4.745E-11
FallTime	5.028E-11
JitterPP	2.875E-11
JitterRMS	9.840E-12
WidthAtBER	9.500E-11
HeightAtBER	0.390

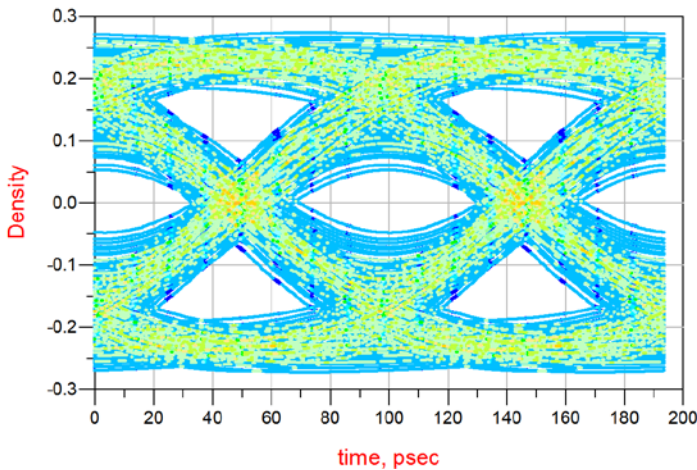
Figure 4: IBIS-AMI simulation (Jitter = 29 ps p-p)

### 6.3 Receiver test #3

Signal source: 10.3125 Gbps, 1 V peak-to-peak differential, 0 dB de-emphasis  
 Channel: 20 inches, 4 mil stripline  
 DS100KRxxx EQ\_Level: 6  
 DS100KRxxx Limit: 0  
 Measurement point: Receiver output



**Figure 5: Cadence simulation (Jitter = 37 ps p-p)**



measurement	Summary
Level1	0.173
Level0	-0.173
LevelMean	6.445E-5
Amplitude	0.345
Height	0.082
Width	6.061E-11
RiseTime	6.491E-11
FallTime	6.304E-11
JitterPP	3.636E-11
JitterRMS	7.848E-12
WidthAtBER	6.158E-11
HeightAtBER	0.099

**Figure 6: IBIS-AMI simulation (Jitter = 36 ps p-p)**

### 6.4 Transmitter test #1

Signal source: 8.0 Gbps, 0.6 V peak-to-peak differential, 0 dB de-emphasis  
 Channel: 15 inches, 4 mil stripline  
 DS100KRxxx DE\_Level: 4  
 DS100KRxxx VOD\_Level: 6  
 Measurement point: Far-end channel output

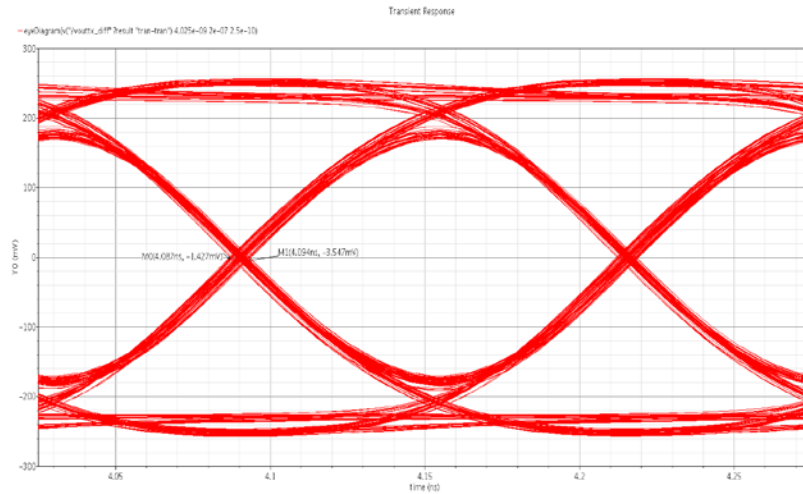
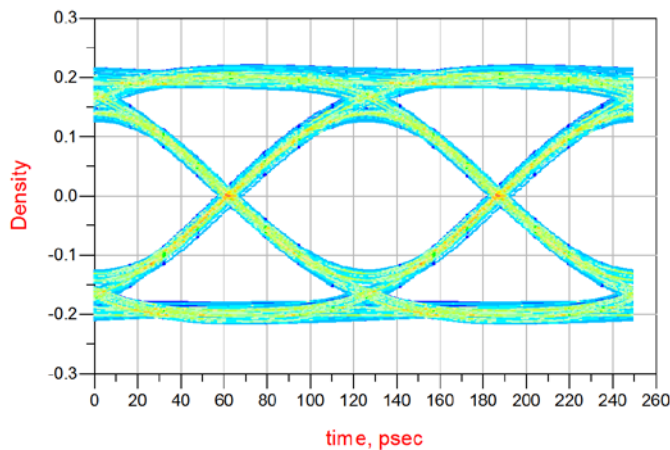


Figure 7: Cadence simulation (Jitter = 7 ps p-p)

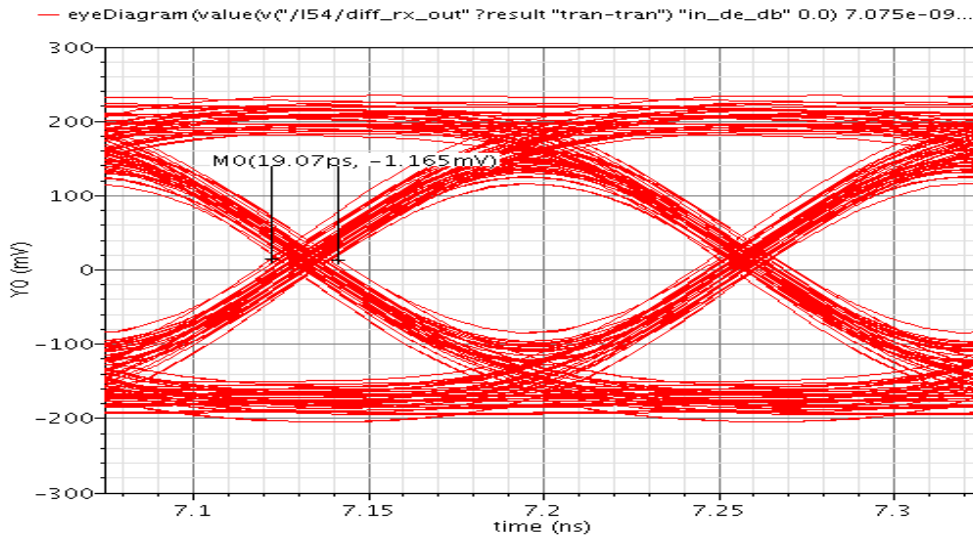


measurement	Summary
Level1	0.166
Level0	-0.166
Amplitude	0.332
Height	0.234
HeightDB	-6.308
Width	1.144E-10
RiseTime	6.359E-11
FallTime	6.356E-11
JitterPP	1.054E-11
JitterRMS	2.108E-12
WidthAtBER	1.144E-10
HeightAtBER	0.250
CrossingLevel	0.000

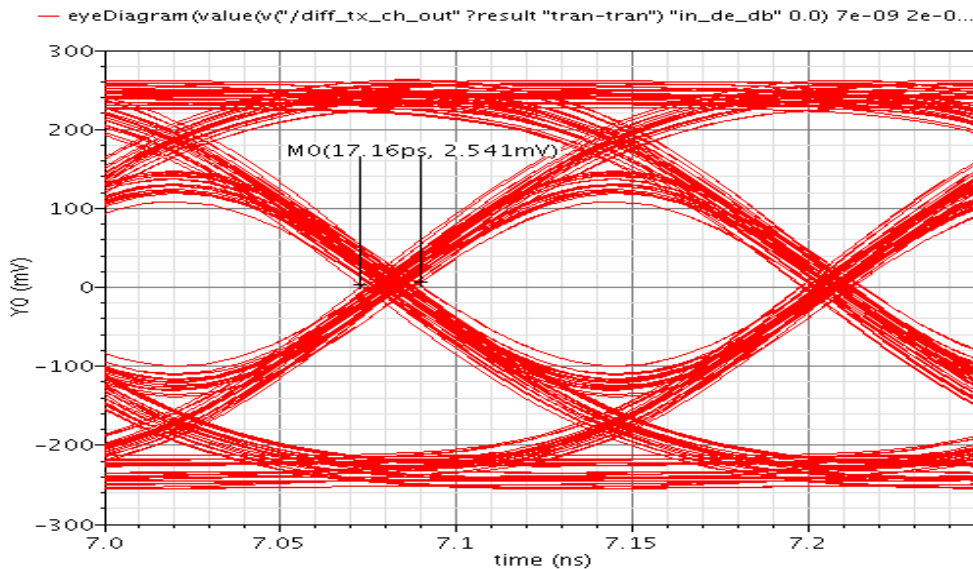
Figure 8: IBIS-AMI simulation (Jitter = 10 ps p-p)

### 6.5 Full channel test #1

Signal source: 8.0 Gbps, 1 V peak-to-peak differential, 0 dB de-emphasis  
 Input channel: 20 inches, 4 mil stripline  
 Output channel: 10 inches, 4 mil stripline  
 DS100KRxxx EQ\_Level: 4  
 DS100KRxxx Limit: 0  
 DS100KRxxx DE\_Level: 2  
 DS100KRxxx VOD\_Level: 7  
 Measurement points: Receiver output and far-end channel output

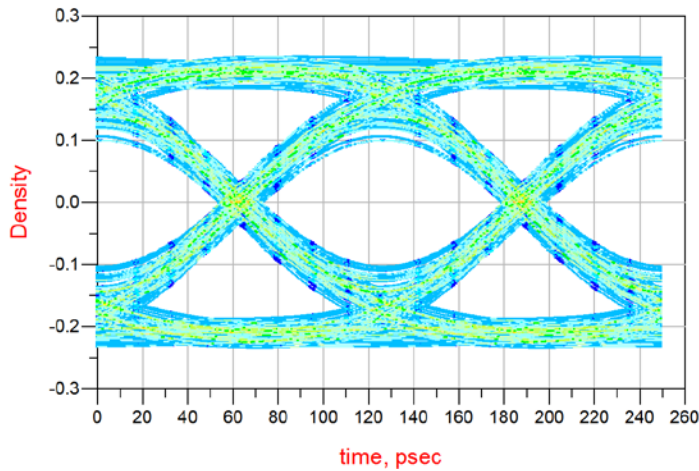


**Figure 9: Cadence simulation, RX output (Jitter = 19 ps p-p)**



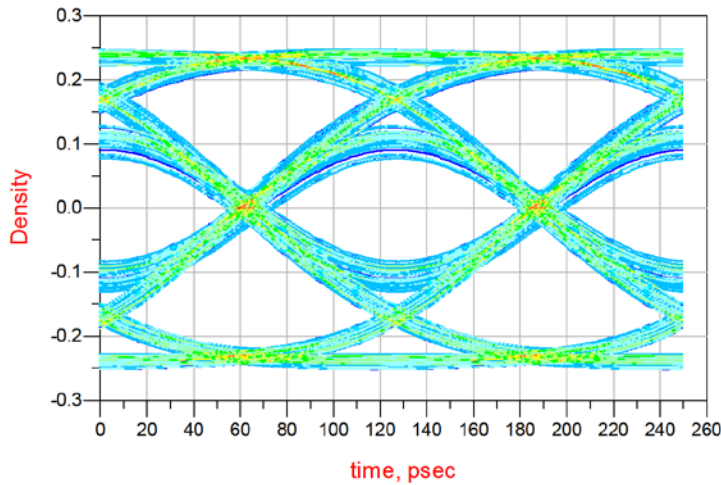
**Figure 10: Cadence simulation, far-end channel output (Jitter = 17 ps p-p)**





measurement	Summary
Level1	0.171
Level0	-0.171
LevelMean	1.023E-4
Amplitude	0.342
Height	0.187
Width	1.044E-10
RiseTime	7.287E-11
FallTime	7.068E-11
JitterPP	2.063E-11
JitterRMS	4.799E-12
WidthAtBER	1.063E-10
HeightAtBER	0.201

Figure 11: IBIS-AMI simulation, RX output (Jitter = 21 ps p-p)



measurement	Summary
Level1	0.171
Level0	-0.170
Amplitude	0.341
Height	0.146
HeightDB	-8.356
Width	1.044E-10
RiseTime	8.332E-11
FallTime	8.338E-11
JitterPP	2.063E-11
JitterRMS	4.160E-12
WidthAtBER	1.056E-10
HeightAtBER	0.160
CrossingLevel	0.000

Figure 12: IBIS-AMI simulation, far-end channel output (Jitter = 21 ps p-p)

## 6.6 Full channel test #2

Signal source: 8.0 Gbps, 1 V peak-to-peak differential, 9 dB de-emphasis\*

Input channel: 20 inches, 4 mil stripline

Output channel: 10 inches, 4 mil stripline

DS100KRxxx EQ\_Level: 4

DS100KRxxx Limit: 0

DS100KRxxx DE\_Level: 2

DS100KRxxx VOD\_Level: 7

Measurement points: Receiver output and far-end channel output

*\*This test case is deliberately over-equalized to show how source de-emphasis passes through the repeater.*

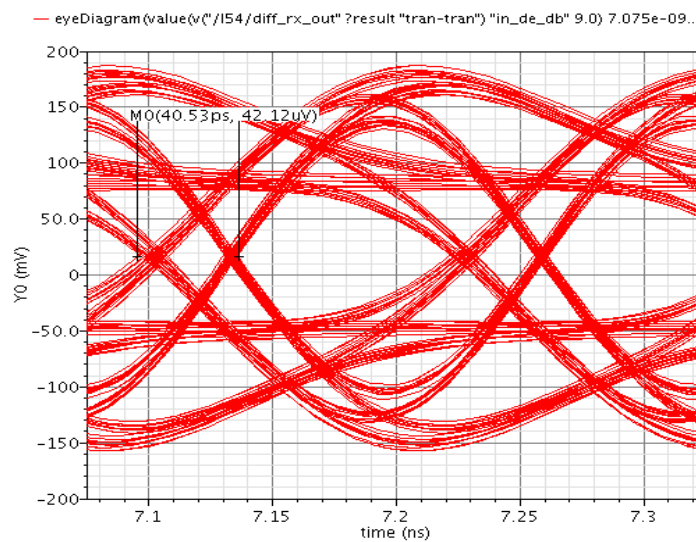


Figure 13: Cadence simulation, RX output (Jitter = 41 ps p-p)



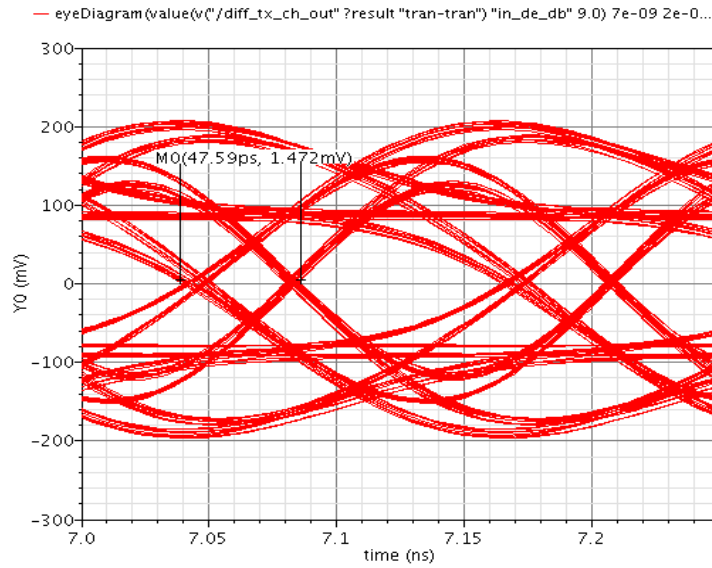


Figure 14: Cadence simulation, far-end channel output (Jitter = 48 ps p-p)

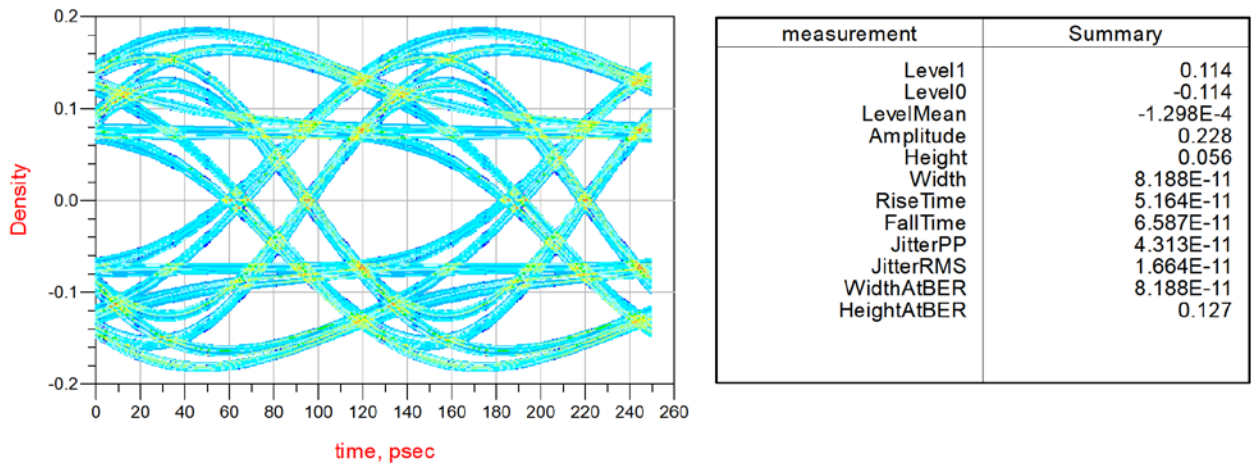
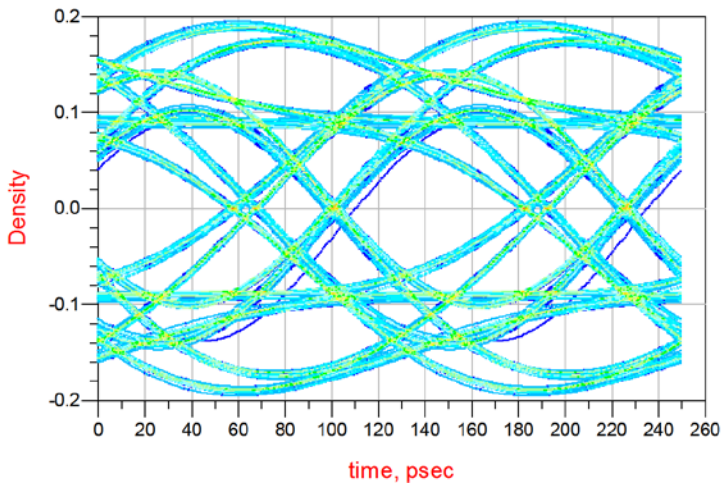


Figure 15: IBIS-AMI simulation, RX output (Jitter = 43 ps p-p)

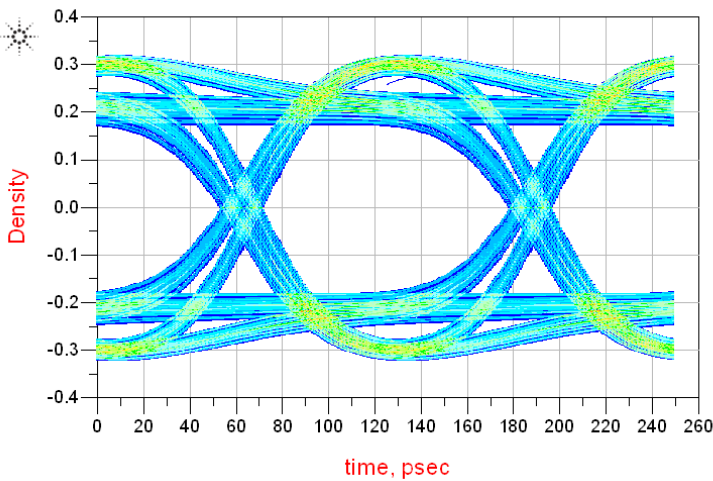


measurement	Summary
Level1	0.112
Level0	-0.112
Amplitude	0.224
Height	0.082
HeightDB	-10.862
Width	7.063E-11
RiseTime	6.753E-11
FallTime	6.763E-11
JitterPP	5.438E-11
JitterRMS	1.970E-11
WidthAtBER	7.250E-11
HeightAtBER	0.123
CrossingLevel	-0.005

Figure 16: IBIS-AMI simulation, far-end channel output (Jitter = 54 ps p-p)

### 6.7 Statistical versus Time Domain: RX test

Signal source: 8.0 Gbps, 1 V peak-to-peak differential, 0 dB de-emphasis  
 Channel: 20 inches, 4 mil stripline  
 DS100KRxxx EQ\_Level: 8  
 DS100KRxxx Limit: 0  
 Measurement point: Receiver output



measurement	Summary
Level1	0.253
Level0	-0.253
Height	0.329
Width	1.069E-10

Figure 17: Time domain (bit-by-bit) simulation result

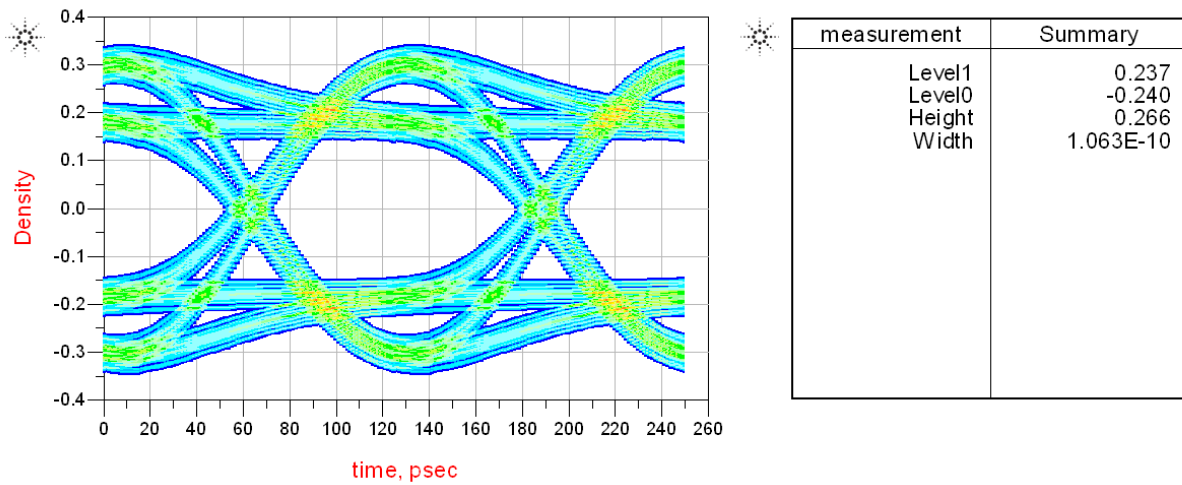


Figure 18: Statistical simulation result

### 6.8 Statistical versus Time Domain: Full Link test

Note: Some tools do not support pure statistical simulations for Redrivers/Retimers, so the results shown below are for two time domain simulations, one executed with init-only processing (i.e. GetWave\_Exists=False), and one executed with GetWave-only processing (i.e. LTI\_mode=0).

Signal source: 8.0 Gbps, 1 V peak-to-peak differential, 0 dB de-emphasis  
 Input channel: 20 inches, 4 mil stripline  
 DS100KRxxx RX EQ\_Level: 8  
 DS100KRxxx RX Limit: 0  
 Output channel: 10 inches, 4 mil stripline  
 DS100KRxxx RX DE\_Level: 1  
 Measurement points: Redriver RX and TX outputs

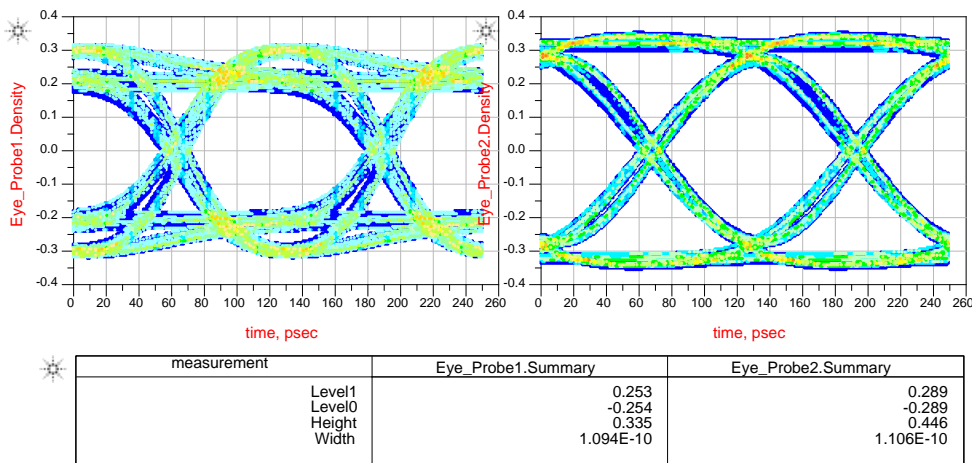


Figure 19: Time domain simulation result; GetWave\_Exists=True, LTI\_mode=0

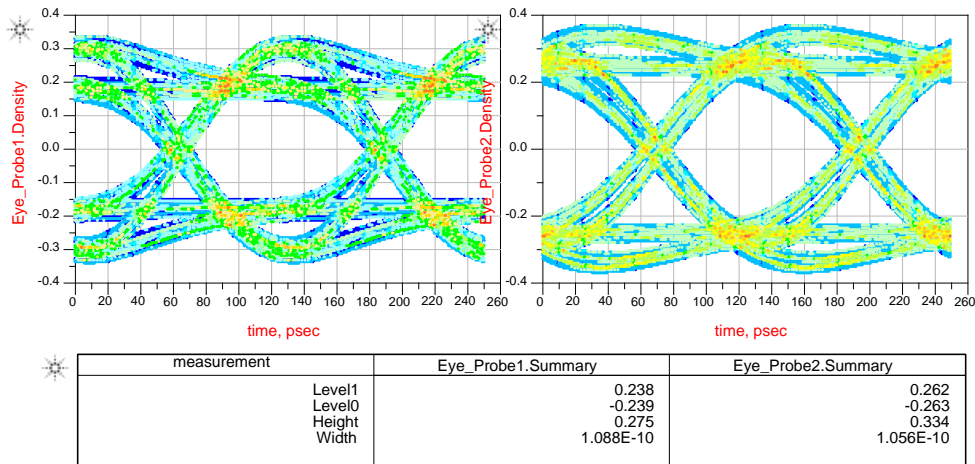


Figure 20: Time domain simulation result; GetWave\_Exists=False, LTI\_mode=1

### 6.9 Comparison between Agilent ADS and SiSoft QCD

Agilent ADS Version: 2014.01

SiSoft QCD version: 2014.05

Signal source: 10.3125 Gbps, 1 V peak-to-peak differential, 0 dB de-emphasis

Input channel: 20 inches stripline

Output channel: 10 inches stripline

DS100KRxxx EQ\_Level: 5

DS100KRxxx Limit: 0

DS100KRxxx DE\_Level: 0

DS100KRxxx VOD\_Level: 7

Measurement point: Output of post channel (10in)

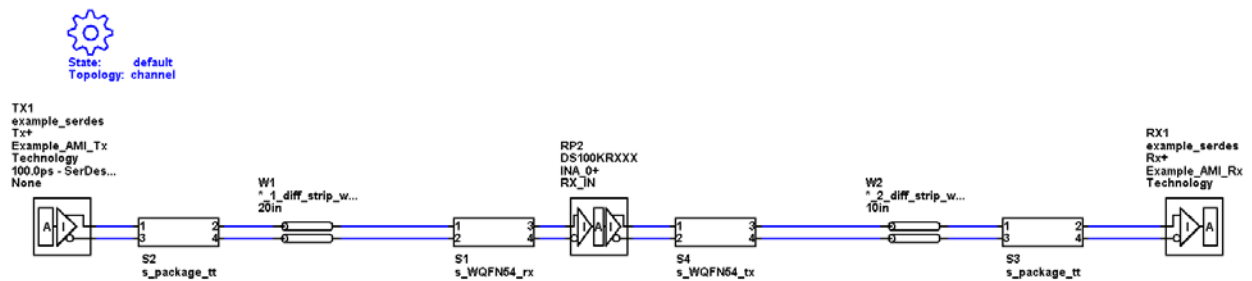


Figure 21: SiSoft QCD testbench

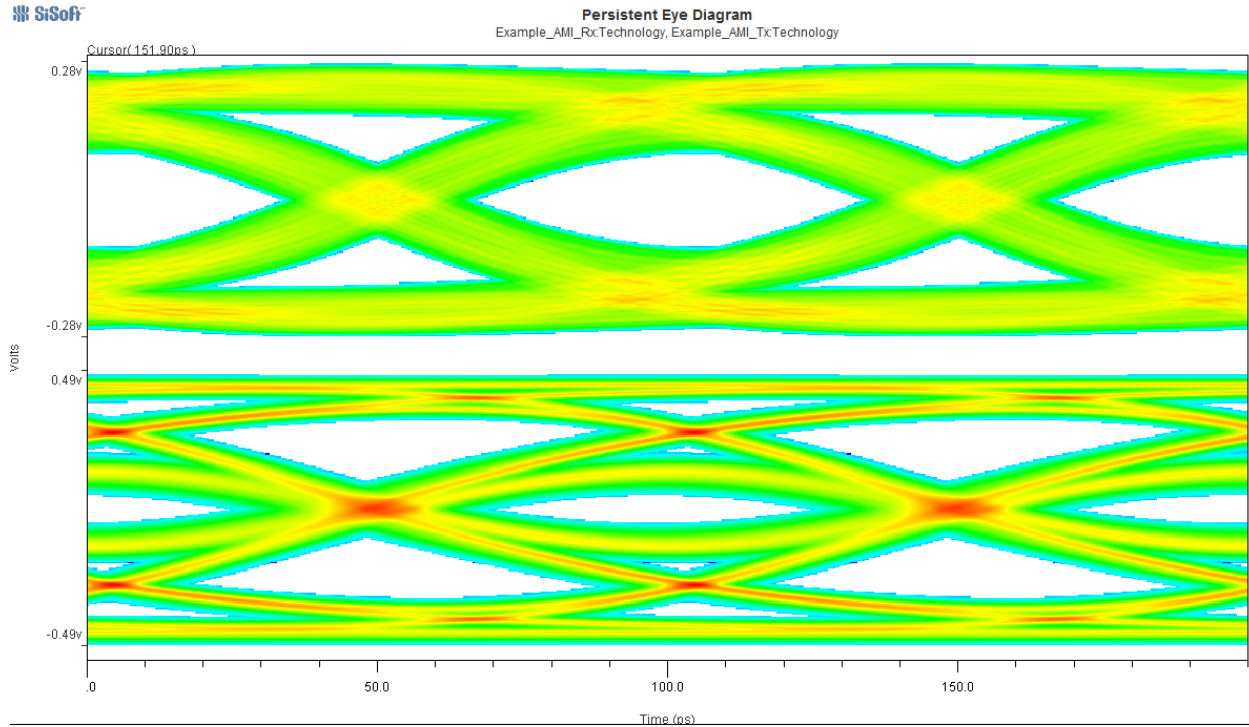


Figure 22: SiSoft QCD output eye diagram (Top: Repeater's internal eye; Bottom: Far-end eye after channel)

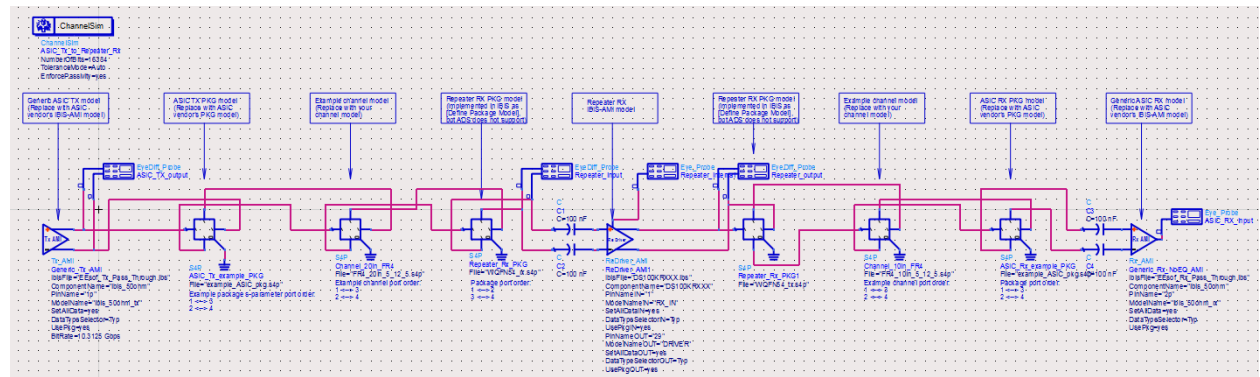


Figure 23: Agilent ADS testbench



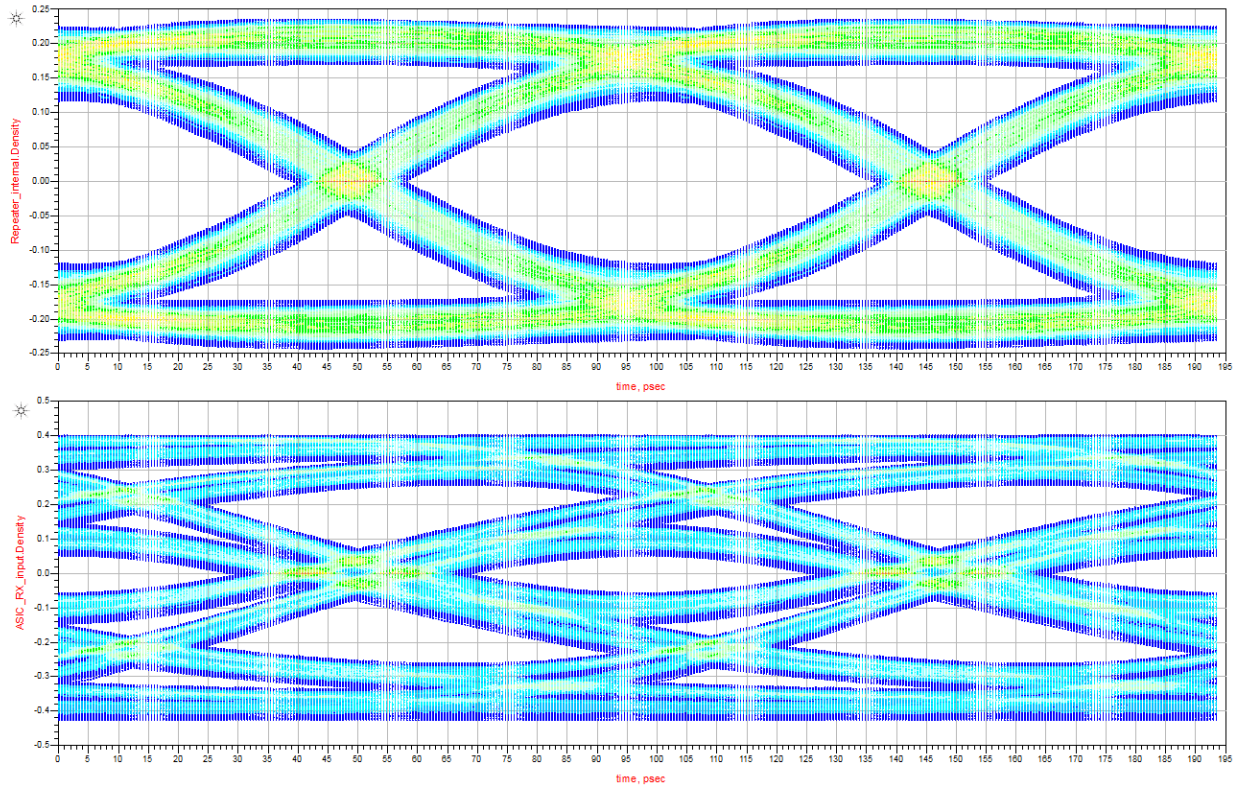


Figure 24: Agilent ADS output eye diagram (Top: Repeater's internal eye; Bottom: Far-end eye after channel)