

WEBENCH® Design Report

 Design : 2 LM2731XMF/NOPB
 LM2731XMF/NOPB 3V-3.7V to 6.50V @ 0.05A

Electrical BOM

Name	Manufacturer	Part Number	Properties	Qty	Price	Footprint
Cf	MuRata	GRM1555C1H471JA01J Series= C0G/NP0	Cap= 470.0 pF VDC= 50.0 V IRMS= 0.0 A	1	\$0.01	0402 3 mm ²
Cin	TDK	C1608X7R1A225K080AC Series= X7R	Cap= 2.2 uF ESR= 4.058 mOhm VDC= 10.0 V IRMS= 2.58266 A	1	\$0.05	0603 5 mm ²
Cout	TDK	CGA5L1X7R1V106K160AC Series= X7R	Cap= 10.0 uF ESR= 2.229 mOhm VDC= 35.0 V IRMS= 4.8593 A	1	\$0.24	1206_190 11 mm ²
D1	ON Semiconductor	MBR120LSFT1G	Vf@Io= 450.0 mV VRRM= 20.0 V	1	\$0.09	SOD-123FL 12 mm ²
L1	Würth Elektronik	74438336100	L= 10.0 uH 322.0 mOhm	1	\$0.93	WE-MAPI_3020 16 mm ²
Rfbb	Yageo	RT0805BRD0713K3L Series= ?	Res= 13.3 kOhm Power= 125.0 mW Tolerance= 0.1%	1	\$0.04	0805 7 mm ²
Rfbt	Susumu Co Ltd	RG1608P-5762-B-T5 Series= RG1608	Res= 57.6 kOhm Power= 100.0 mW Tolerance= 0.1%	1	\$0.06	0603 5 mm ²
Rp	Vishay-Dale	CRCW040251K1FKED Series= CRCW..e3	Res= 51.1 kOhm Power= 63.0 mW Tolerance= 1.0%	1	\$0.01	0402 3 mm ²
U1	Texas Instruments	LM2731XMF/NOPB	Switcher	1	\$0.68	DBV0005A 15 mm ²

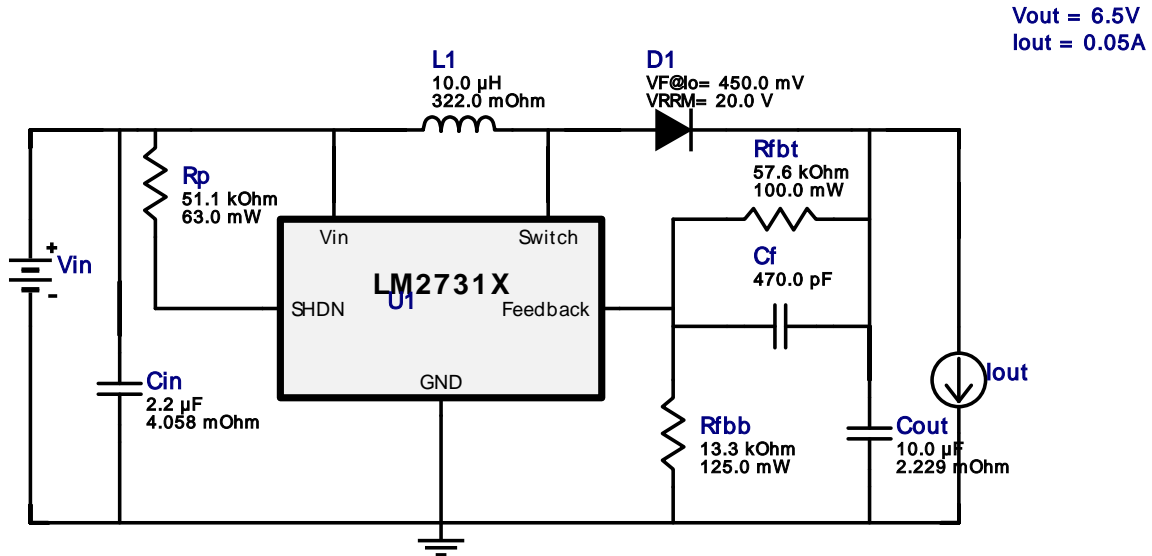
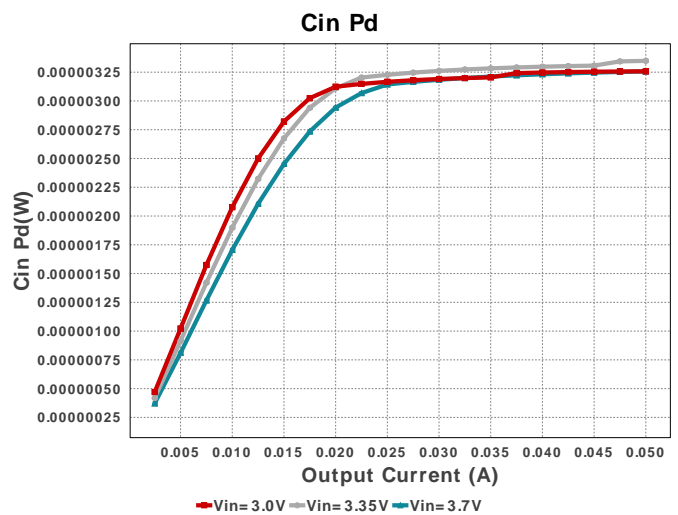
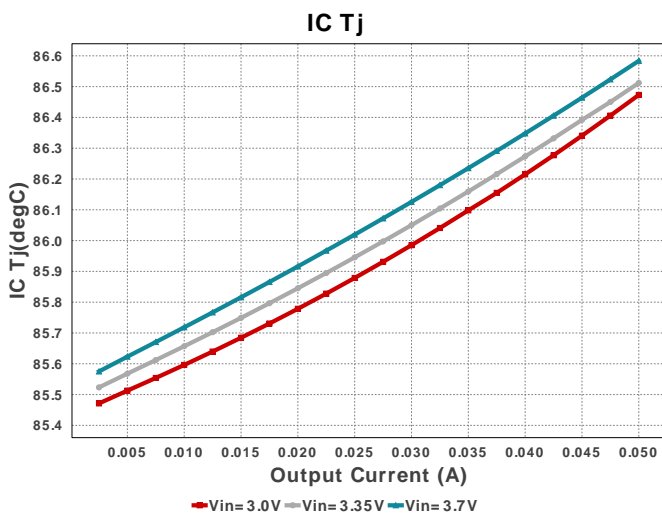
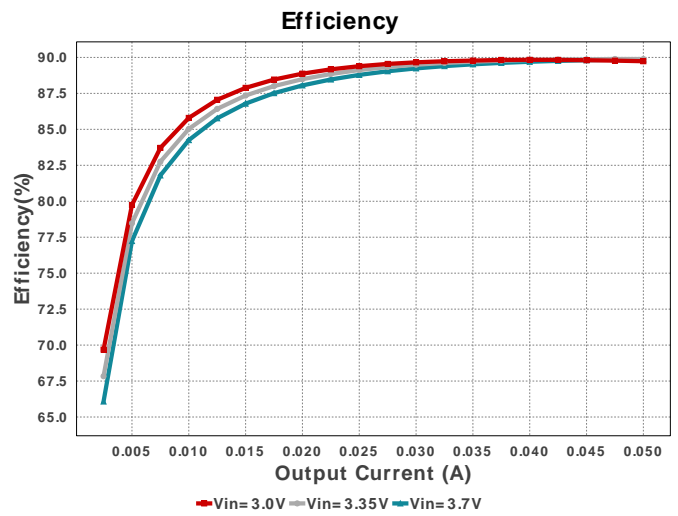
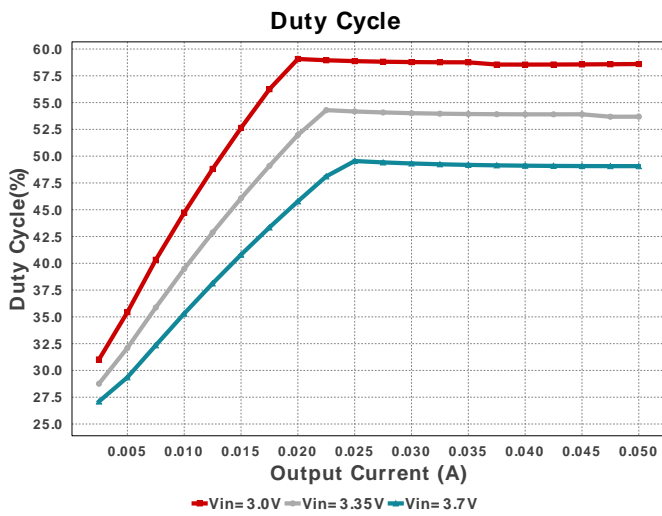
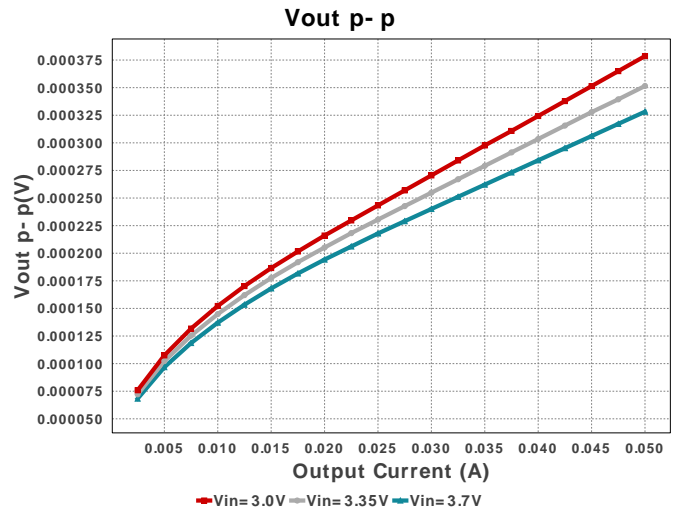
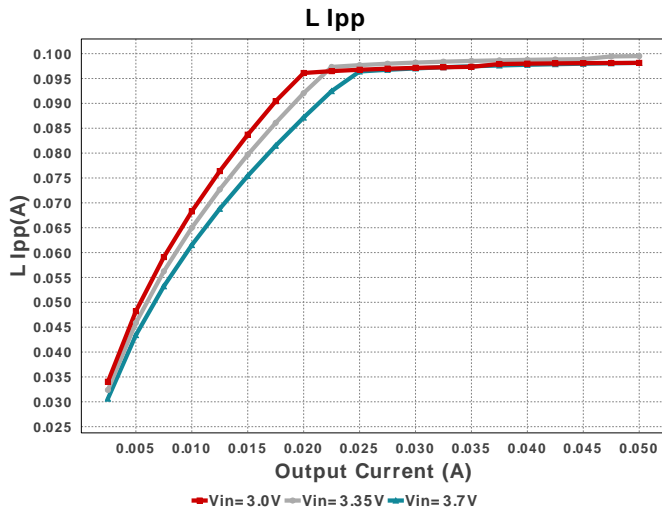
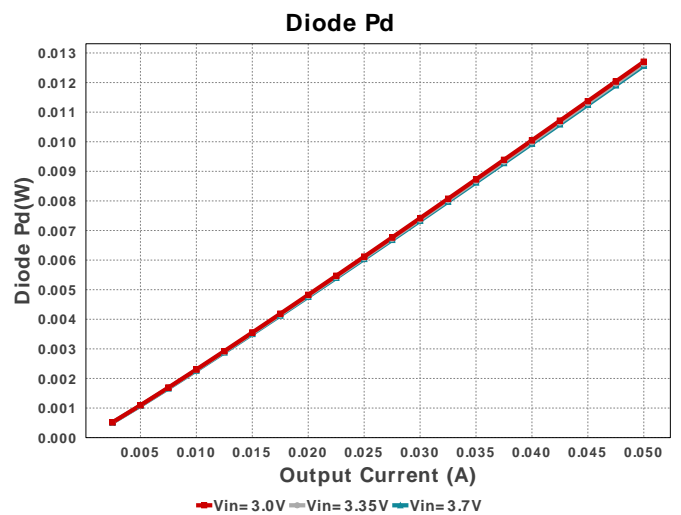
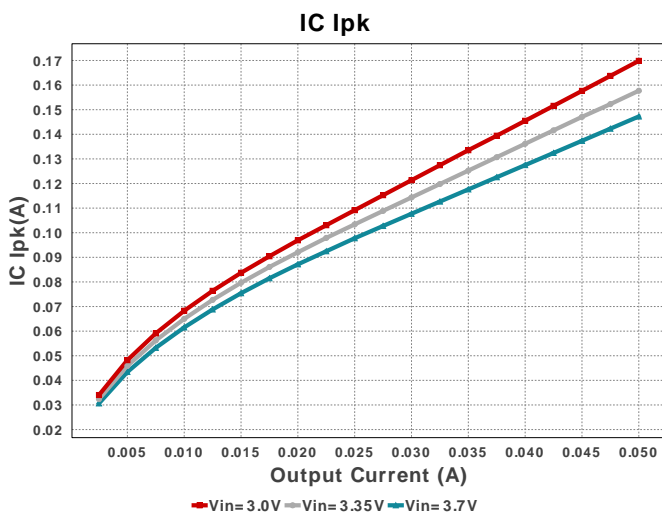
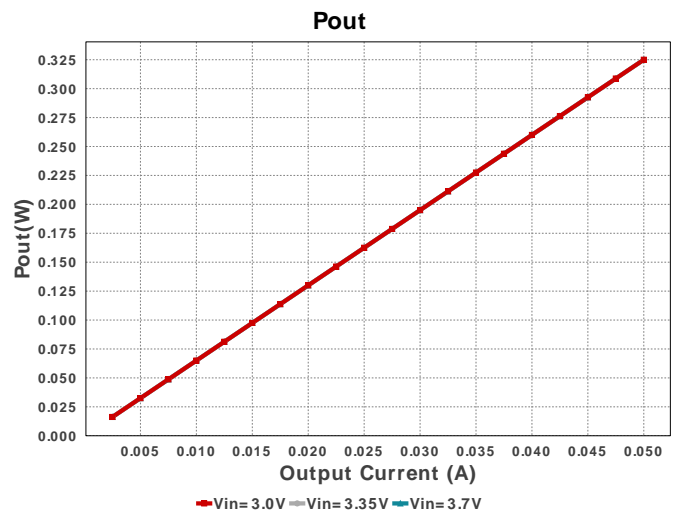
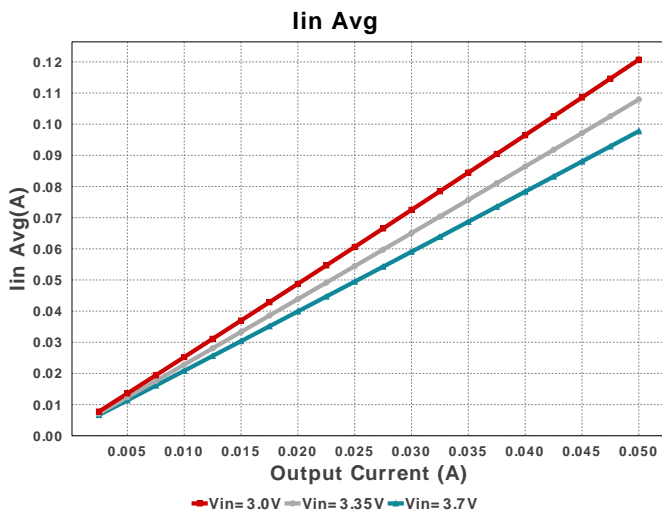
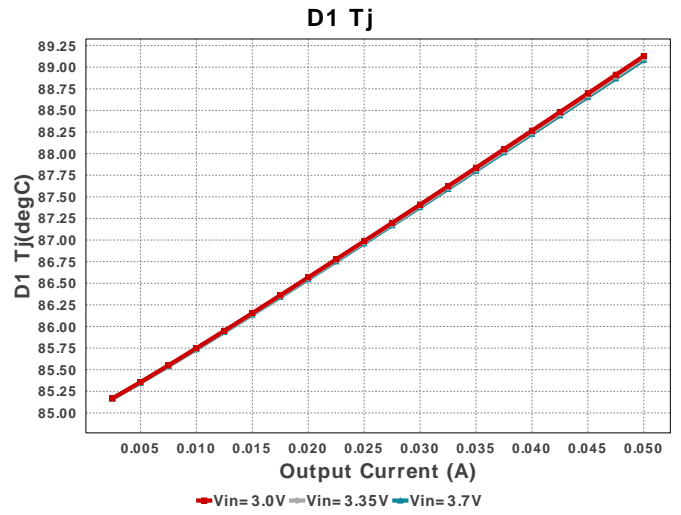
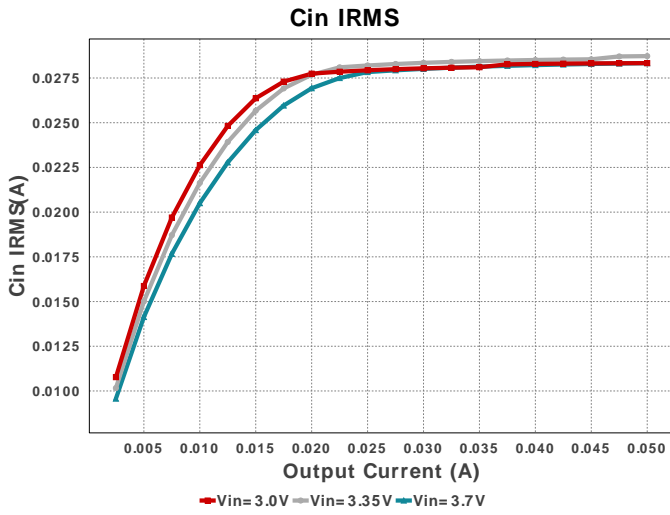

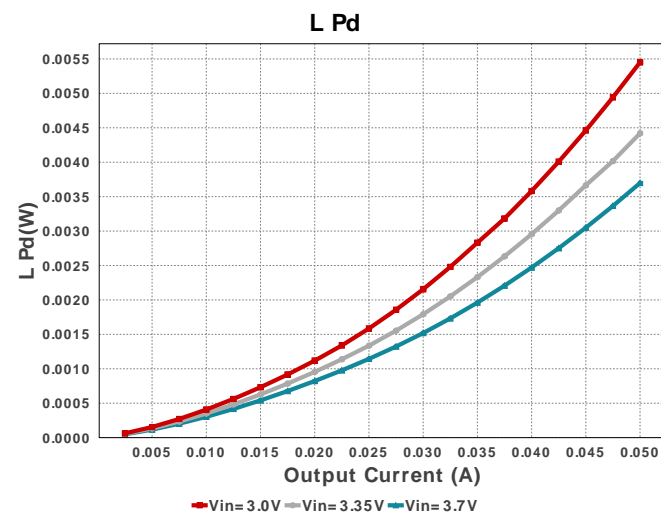
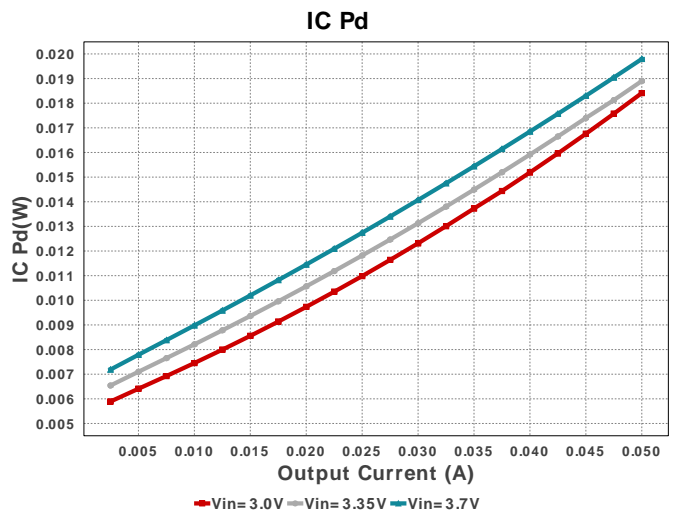
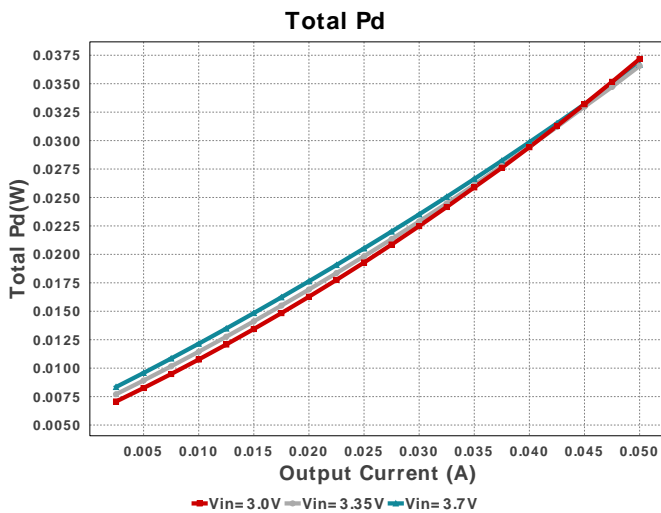
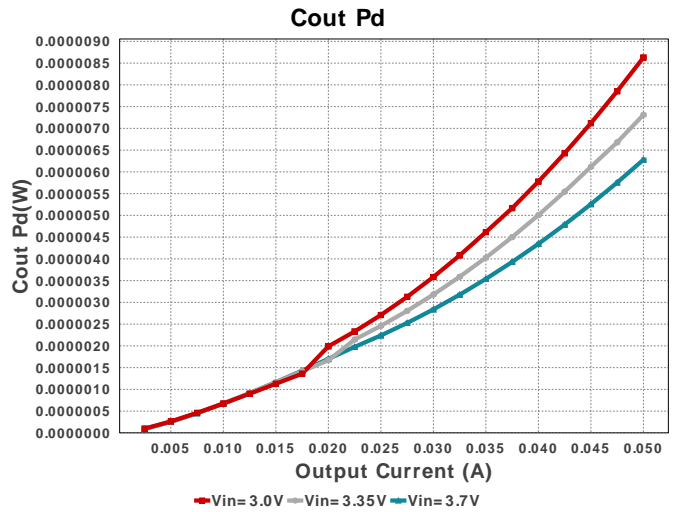
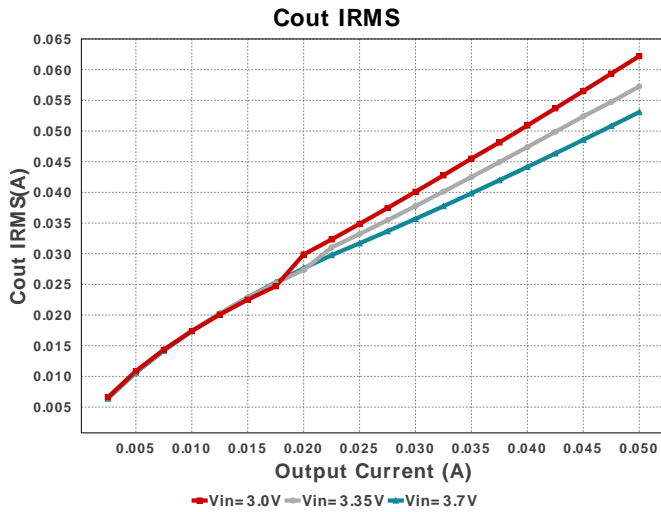



Operating Values

#	Name	Value	Category	Description
1.	BOM Count	9		Total Design BOM count
2.	Total BOM	\$2.11		Total BOM Cost
3.	Cin IRMS	28.332 mA	Capacitor	Input capacitor RMS ripple current
4.	Cin Pd	3.257 μ W	Capacitor	Input capacitor power dissipation
5.	Cout IRMS	62.216 mA	Capacitor	Output capacitor RMS ripple current
6.	Cout Pd	8.628 μ W	Capacitor	Output capacitor power dissipation
7.	D1 Tj	89.128 degC	Diode	D1 junction temperature
8.	Diode Pd	12.702 mW	Diode	Diode power dissipation
9.	IC Ipk	169.843 mA	IC	Peak switch current in IC
10.	IC Pd	18.412 mW	IC	IC power dissipation
11.	IC Tj	86.473 degC	IC	IC junction temperature

#	Name	Value	Category	Description
12.	Iin Avg	120.72 mA	IC	Average input current
13.	L Ipp	98.144 mA	Inductor	Peak-to-peak inductor ripple current
14.	L Pd	5.45 mW	Inductor	Inductor power dissipation
15.	Cin Pd	3.257 μ W	Power	Input capacitor power dissipation
16.	Cout Pd	8.628 μ W	Power	Output capacitor power dissipation
17.	Diode Pd	12.702 mW	Power	Diode power dissipation
18.	IC Pd	18.412 mW	Power	IC power dissipation
19.	L Pd	5.45 mW	Power	Inductor power dissipation
20.	Total Pd	37.172 mW	Power	Total Power Dissipation
21.	Duty Cycle	58.599 %	System	Duty cycle
22.	Efficiency	89.736 %	System Information	Steady state efficiency
23.	FootPrint	76.0 mm ²	System Information	Total Foot Print Area of BOM components
24.	Frequency	1.6 MHz	System Information	Switching frequency
25.	Iout	50.0 mA	System Information	Iout operating point
26.	Mode	CCM	System Information	Conduction Mode
27.	Pout	325.0 mW	System Information	Total output power
28.	Vin	3.0 V	System Information	Vin operating point
29.	Vout Actual	6.557 V	System Information	Vout Actual calculated based on selected voltage divider resistors
30.	Vout Tolerance	2.198 %	System Information	Vout Tolerance based on IC Tolerance (no load) and voltage divider resistors if applicable
31.	Vout p-p	378.579 μ V	System Information	Peak-to-peak output ripple voltage

Design Inputs

Name	Value	Description
Iout	50.0 m	Maximum Output Current
VinMax	3.7	Maximum input voltage
VinMin	3.0	Minimum input voltage
Vout	6.5	Output Voltage
base_pn	LM2731X	Base Product Number
source	DC	Input Source Type
Ta	85.0	Ambient temperature

WEBENCH® Assembly

Component Testing

Some published data on components in datasheets such as Capacitor ESR and Inductor DC resistance is based on conservative values that will guarantee that the components always exceed the specification. For design purposes it is usually better to work with typical values. Since this data is not always available it is a good practice to measure the Capacitance and ESR values of C_{in} and C_{out} , and the inductance and DC resistance of $L1$ before assembly of the board. Any large discrepancies in values should be electrically simulated in WEBENCH to check for instabilities and thermally simulated in WebTHERM to make sure critical temperatures are not exceeded.

Soldering Component to Board

If board assembly is done in house it is best to tack down one terminal of a component on the board then solder the other terminal. For surface mount parts with large tabs, such as the DPAK, the tab on the back of the package should be pre-tinned with solder, then tacked into place by one of the pins. To solder the tab down to the board place the iron down on the board while resting against the tab, heating both surfaces simultaneously. Apply light pressure to the top of the plastic case until the solder flows around the part and the part is flush with the PCB. If the solder is not flowing around the board you may need a higher wattage iron (generally 25W to 30W is enough).

Initial Startup of Circuit

It is best to initially power up the board by setting the input supply voltage to the lowest operating input voltage 3.0V and set the input supply's current limit to zero. With the input supply off connect up the input supply to V_{in} and GND. Connect a digital volt meter and a load if needed to set the minimum load of the design from V_{out} and GND. Turn on the input supply and slowly turn up the current limit on the input supply. If the voltage starts to rise on the input supply continue increasing the input supply current limit while watching the output voltage. If the current increases on the input supply, but the voltage remains near zero, then there may be a short or a component misplaced on the board. Power down the board and visually inspect for solder bridges and recheck the diode and capacitor polarities. Once the power supply circuit is operational then more extensive testing may include full load testing, transient load and line tests to compare with simulation results.

Load Testing

The setup is the same as the initial startup, except that an additional digital voltmeter is connected between V_{in} and GND, a load is connected between V_{out} and GND and a current meter is connected in series between V_{out} and the load. The load must be able to handle at least rated output power + 50% (7.5 watts for this design). Ideally the load is supplied in the form of a variable load test unit. It can also be done in the form of suitably large power resistors. When using an oscilloscope to measure waveforms on the prototype board, the ground leads of the oscilloscope probes should be as short as possible and the area of the loop formed by the ground lead should be kept to a minimum. This will help reduce ground lead inductance and eliminate EMI noise that is not actually present in the circuit.

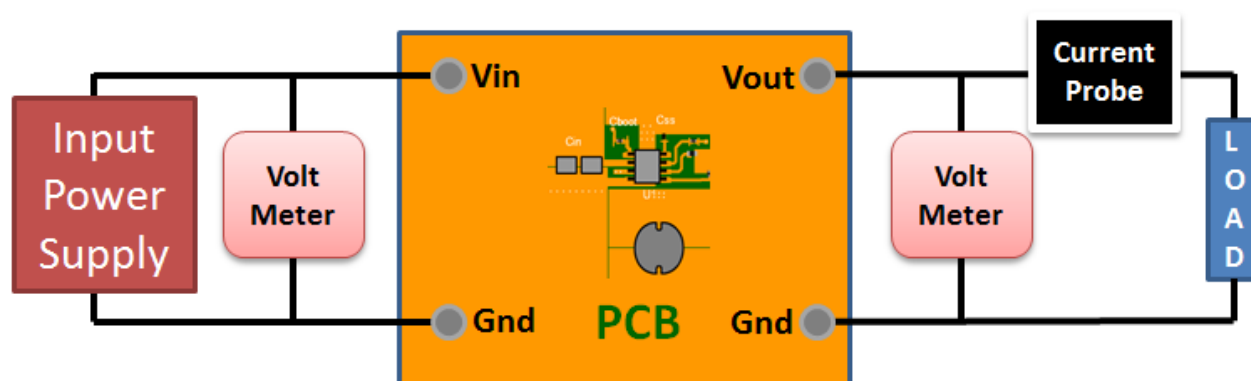

WEBENCH® Electrical Simulation Report

Design Id = 2

sim_id = 6

Simulation Type = Load Transient

VinMax = 5.5V

Iout = 0.05A

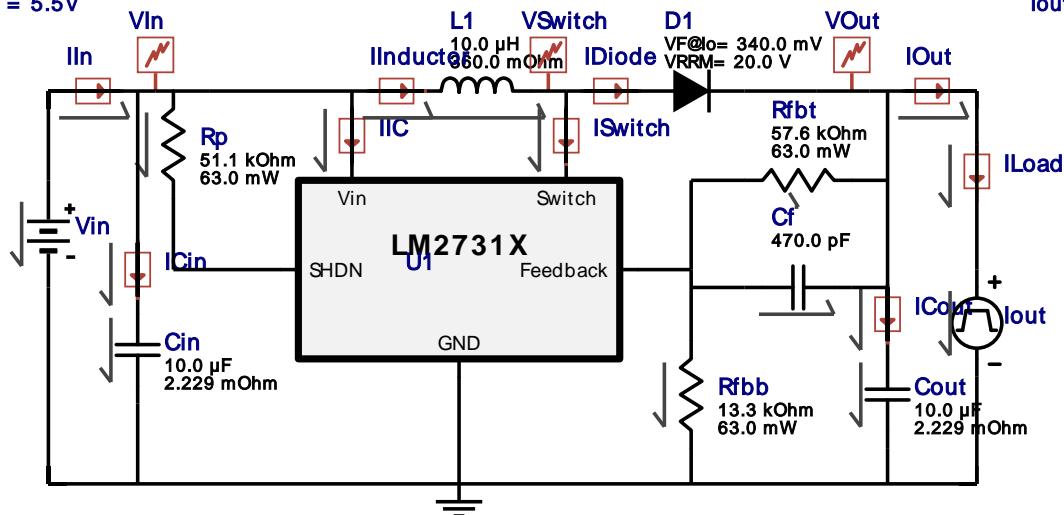

Simulation Parameters

#	Name	Parameter Name	Description	Values
1.	L1	IC	no description	-0.08049535603715172
2.	Iout	signal_type	Signal Type	PULSE
		I1	Initial Load Current	0.05 A
		I2	Minimum Load Current	0.005 A
		Td	Initial Time Delay	900u s
		Tr	Rise Time	100u s
		Tf	Fall Time	100u s
		Pw	Pulse Width	1.3m s

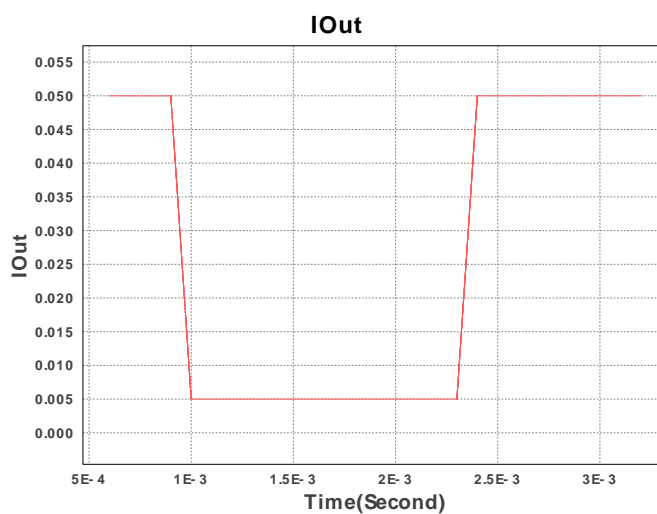
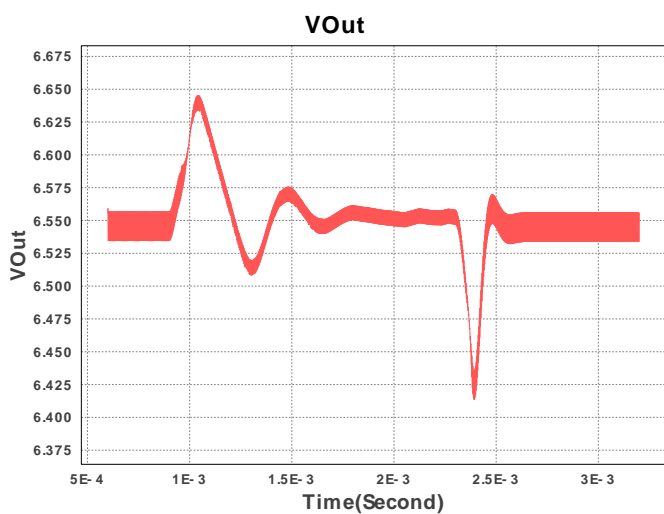

Design Id = 2
 sim_id = 7
 Simulation Type = Input Transient

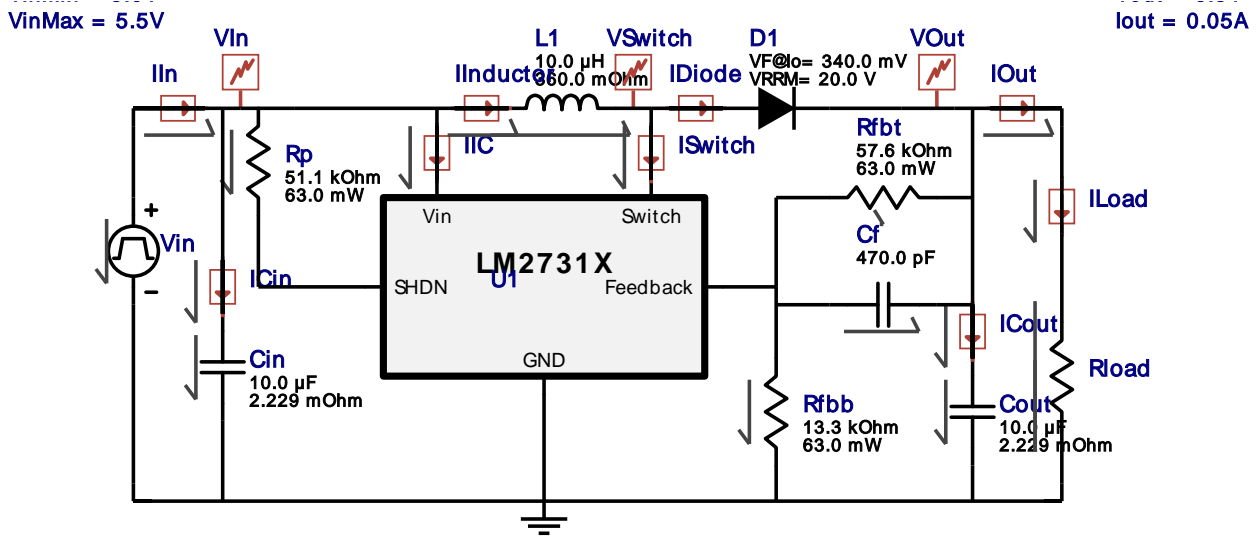

Simulation Parameters

#	Name	Parameter Name	Description	Values
1.	L1	IC	no description	-0.11403508771929827
2.	Rload	R	Load Resistance	130.0

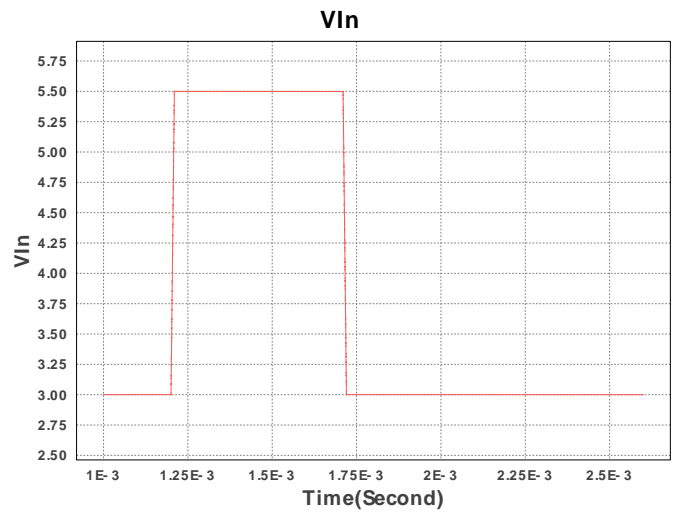
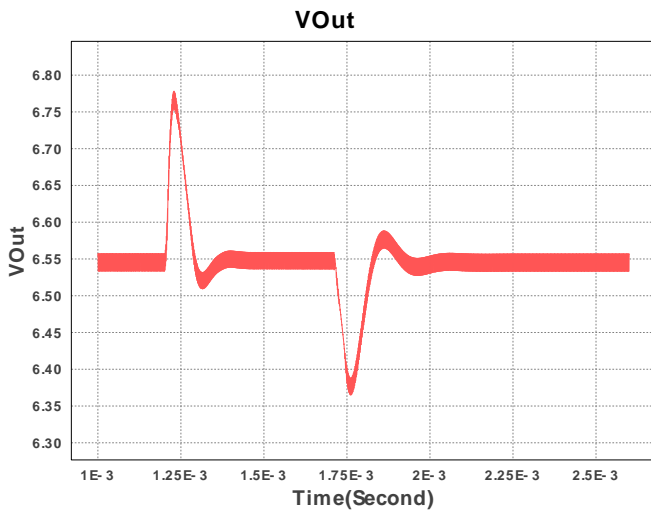

Design Id = 2

sim_id = 8

Simulation Type = Steady State

VinMax = 5.5V

Iout = 0.05A

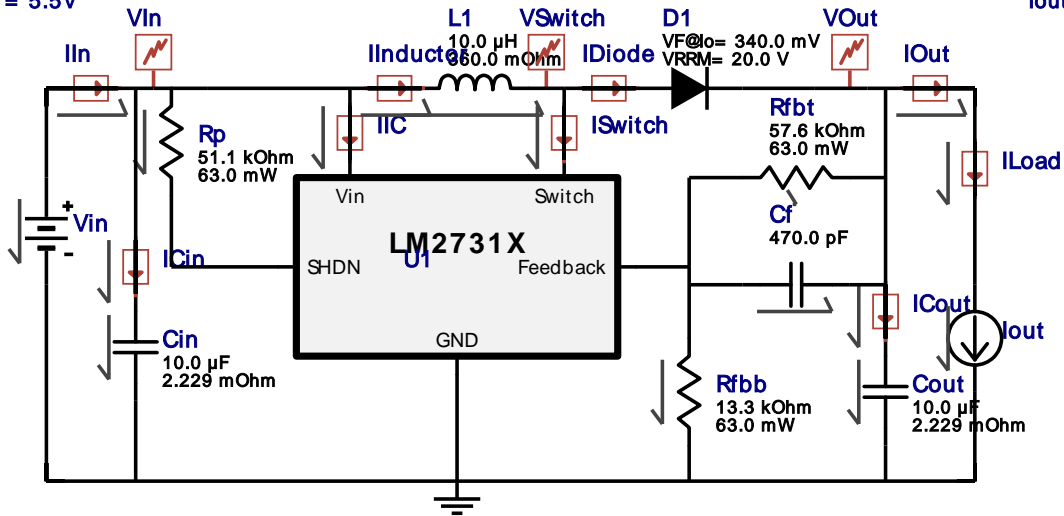

Simulation Parameters

#	Name	Parameter Name	Description	Values
1.	Cout	IC	Initial Voltage	6.5 V
2.	L1	IC	Initial Current	-0.08049535603715172 A
3.	Iout	I	Load Current	0.05 A

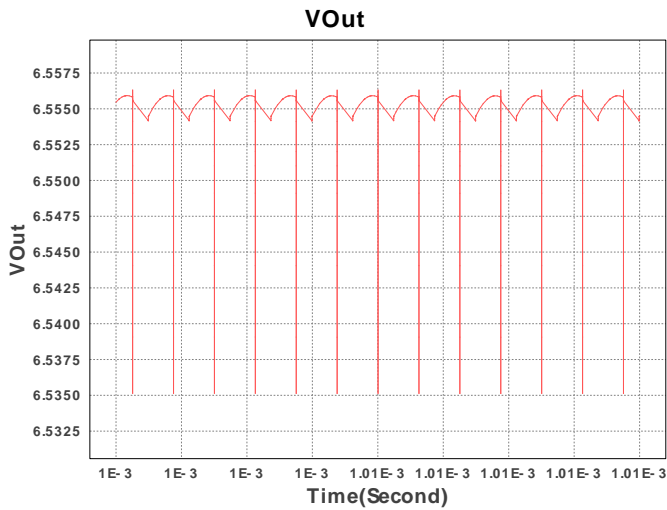

Design Id = 2
 sim_id = 11
 Simulation Type = Startup

VinMax = 3.7V

Iout = 0.05A

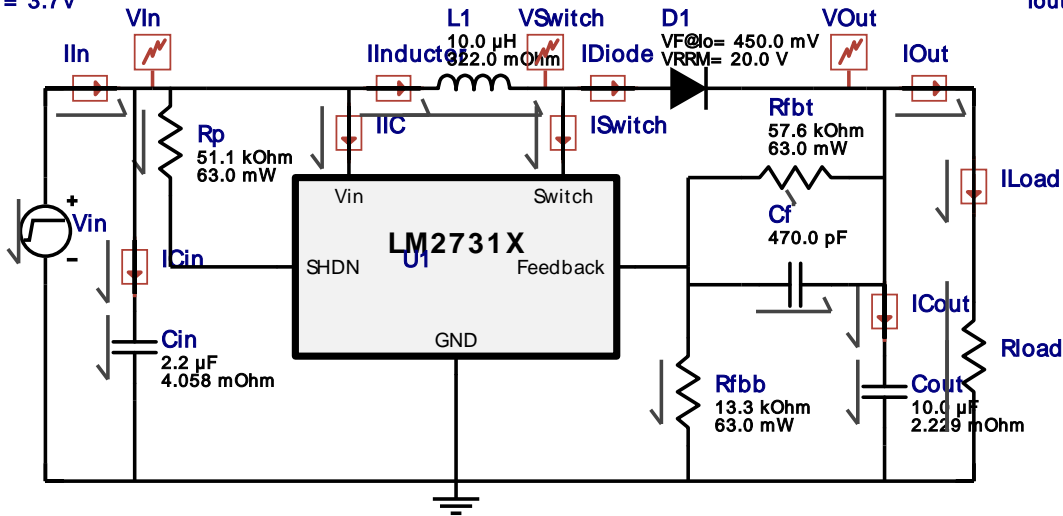

Simulation Parameters

#	Name	Parameter Name	Description	Values
1.	Rload	R	Load Resistance	130.0

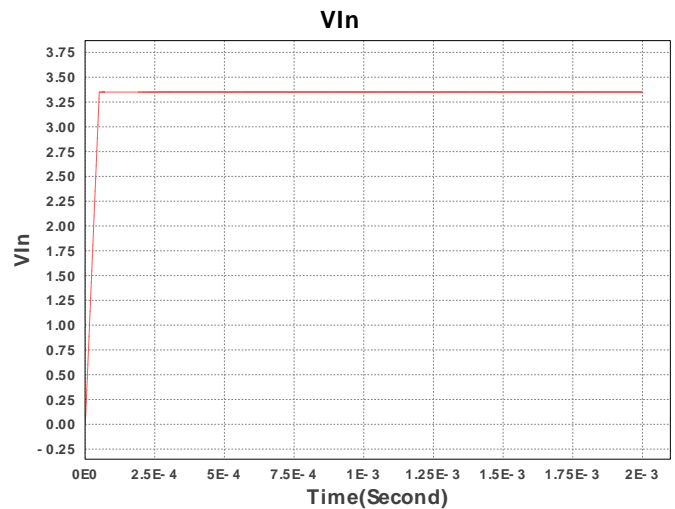
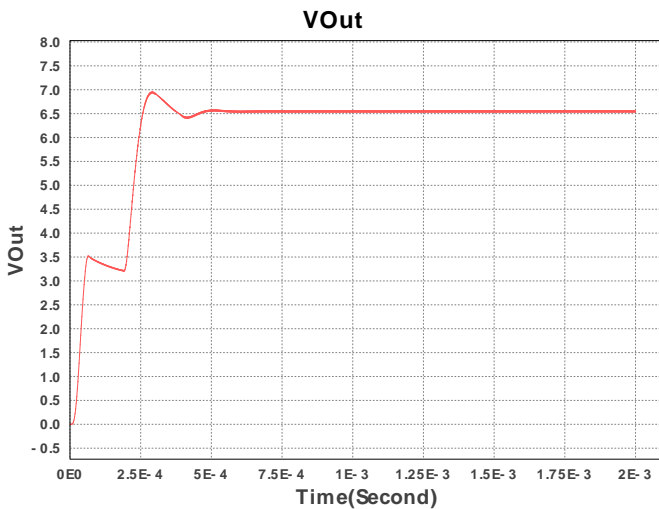

Design Assistance

1. Master key : 202DDE02F07E0483[v1]
2. **LM2731X** Product Folder : <http://www.ti.com/product/LM2731X> : contains the data sheet and other resources.

Important Notice and Disclaimer

TI provides technical and reliability data (including datasheets), design resources (including reference designs), application or other design advice, web tools, safety information, and other resources AS IS and with all faults, and disclaims all warranties. These resources are intended for skilled developers designing with TI products. You are solely responsible for (1) selecting the appropriate TI products for your application, (2) designing, validating and testing your application, and (3) ensuring your application meets applicable standards, and any other safety, security, or other requirements.

These resources are subject to change without notice. TI grants you permission to use these resources only for development of an application that uses the TI products described in the resource. Other reproduction and display of these resources is prohibited. No license is granted to any other TI intellectual property right or to any third party intellectual property right. TI disclaims responsibility for, and you will fully indemnify TI and its representatives against, any claims, damages, costs, losses, and liabilities arising out of your use of these resources.

Providing these resources does not expand or otherwise alter TI's applicable Terms of Sale or other applicable terms available either on ti.com or provided in conjunction with TI products.