

■ Vout=5V

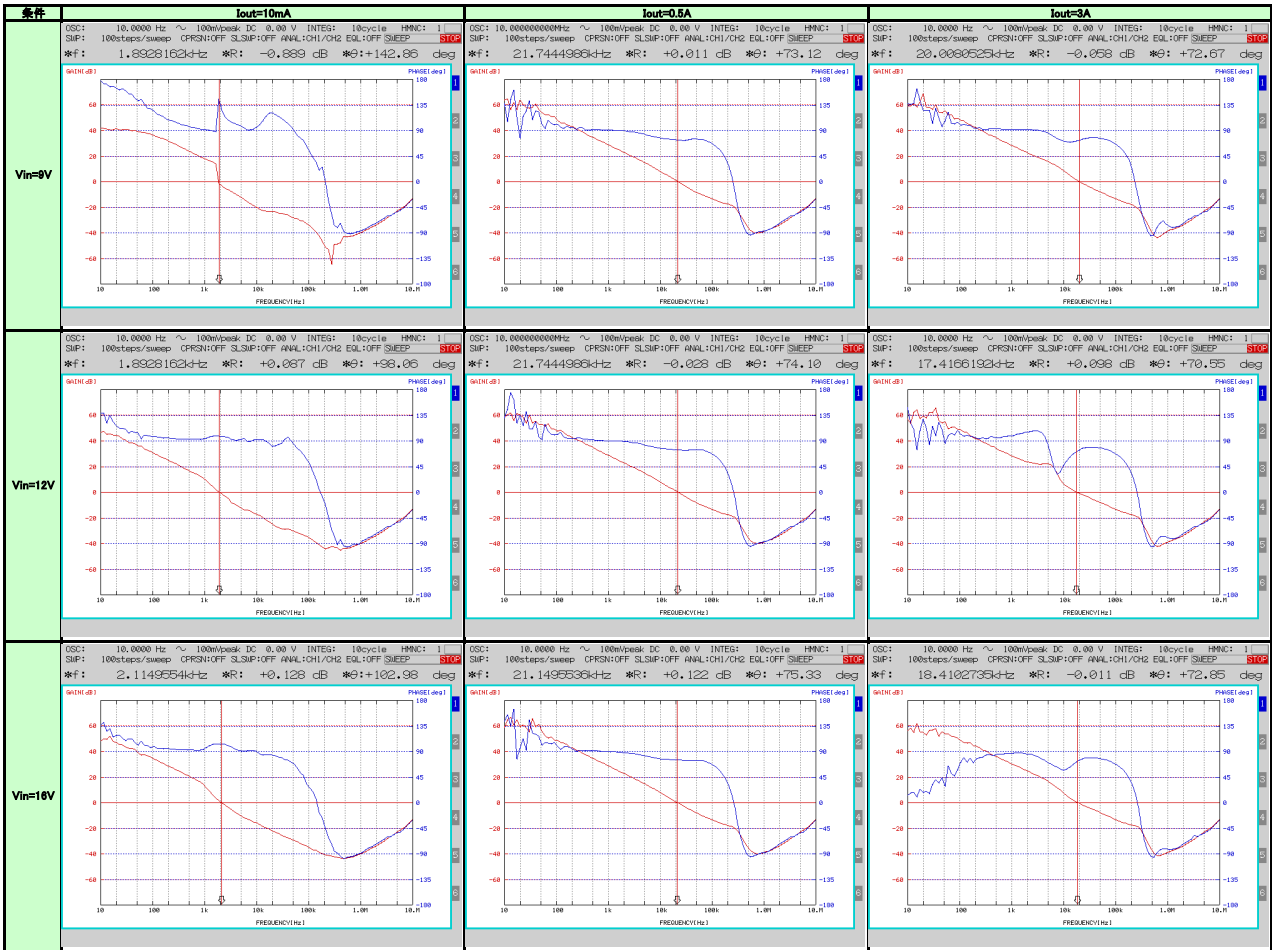

+B-V50 3A@2.1MHz

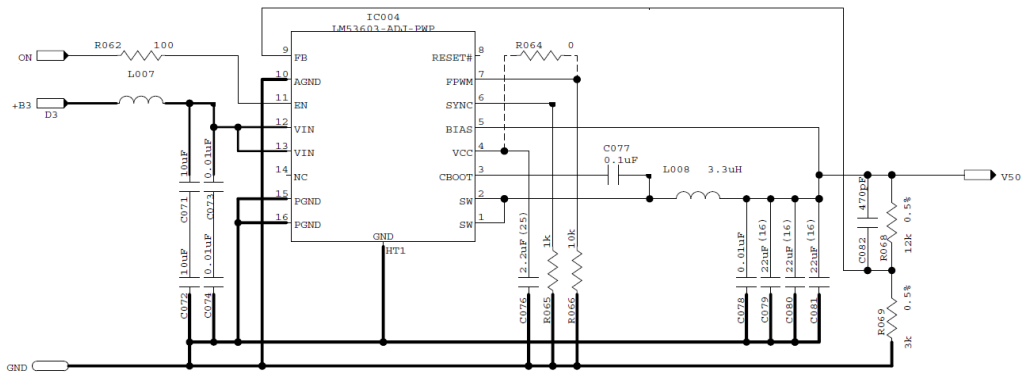

Vout=3.3V

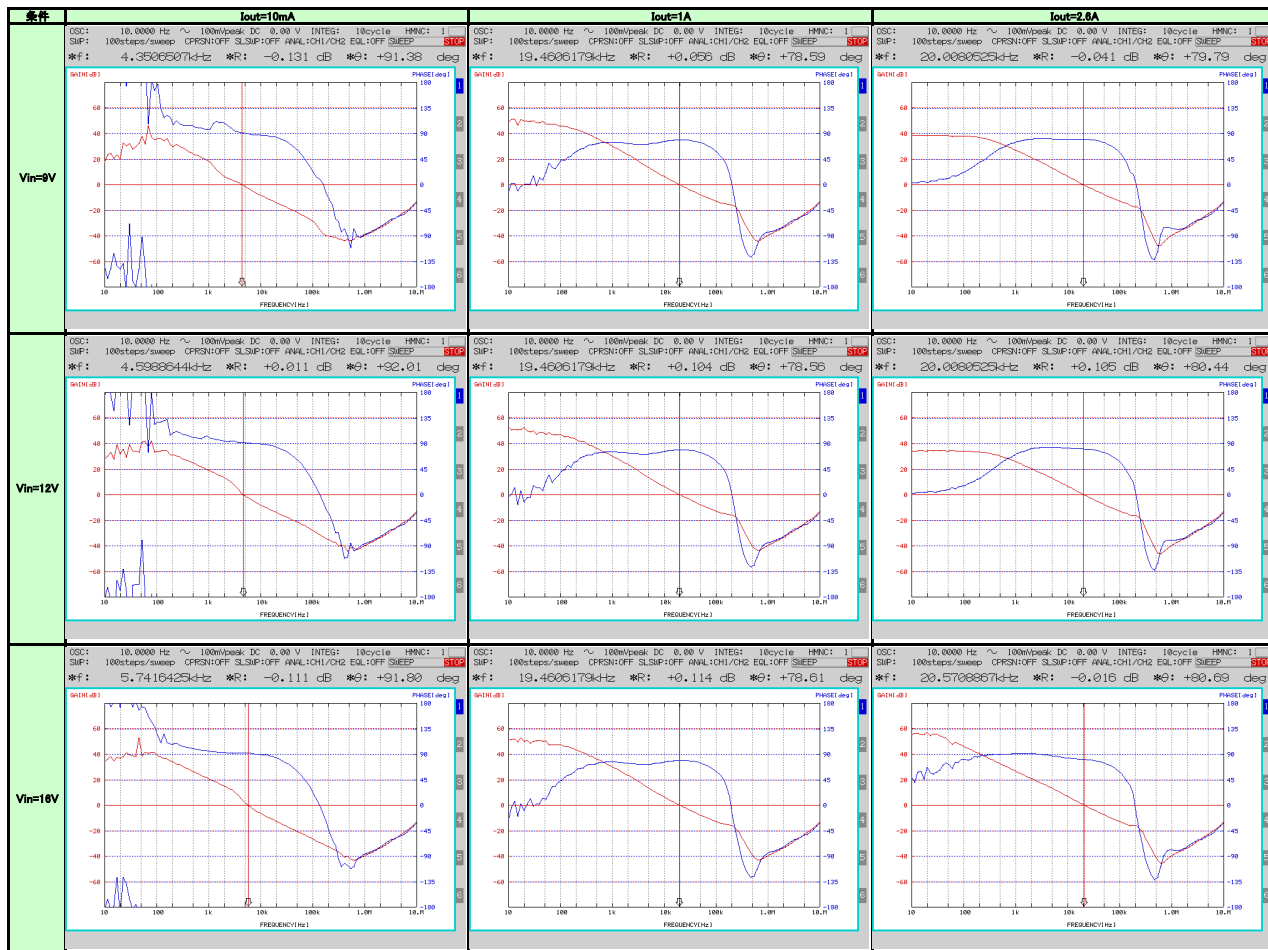

+B → V33 3A@2.1MHz

