

VMONx monitoring VMONx=0.8V

	VPRE	BUCK3	LDO1	LDO2
VCC	5V	3.3V	5V	5V
R1	115K	68K	115K	115K
R2	22K	22K	22K	22K

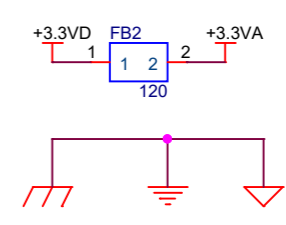
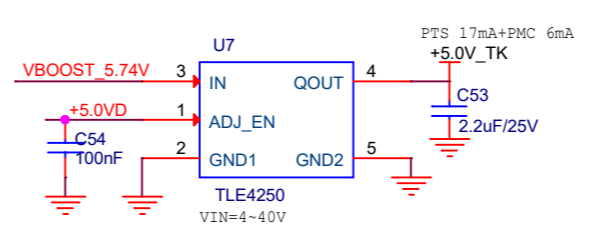
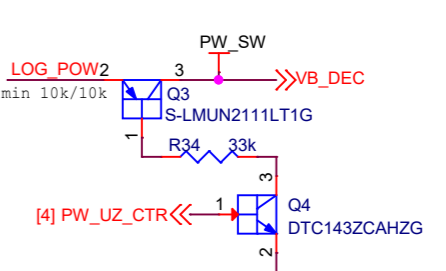
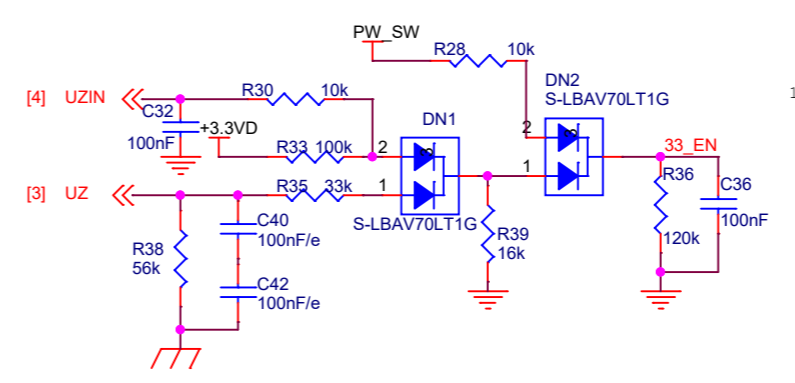

Title		<Title>
Size	B	Document Number
Date:		Tuesday, January 02, 2024
Sheet	1	of 4
Rev	<RevCode>	