

PWR & REVERSE BATT PROT

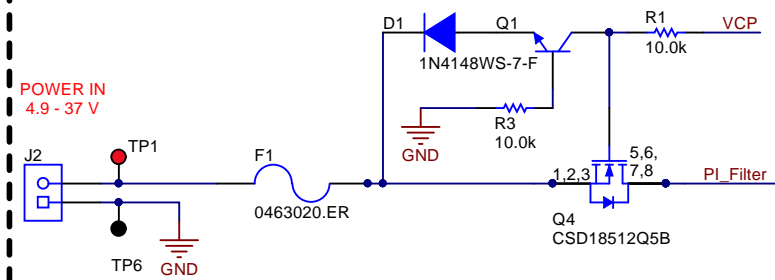

DRV8x06x-Q1 OR DRV8705x-Q1

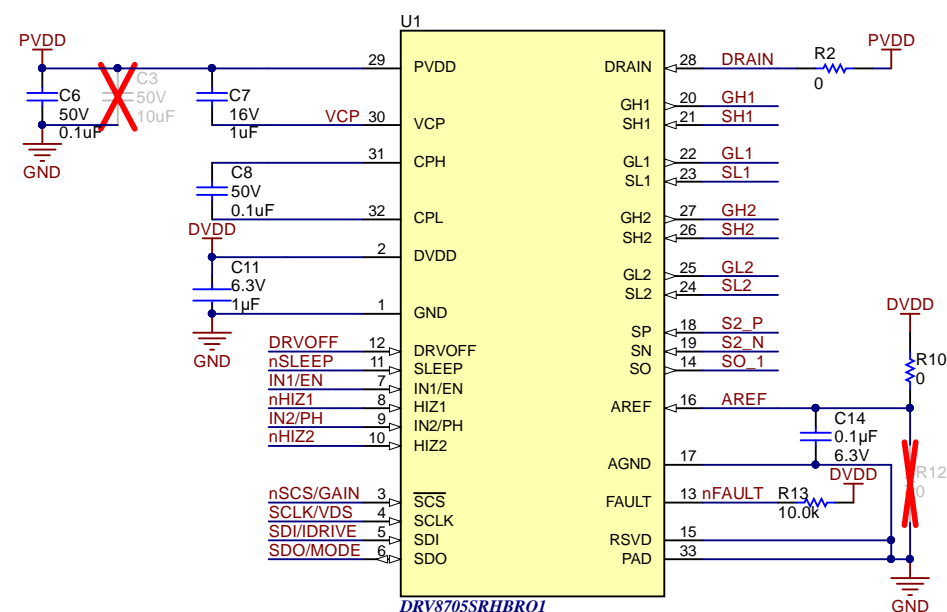

H-BRIDGE

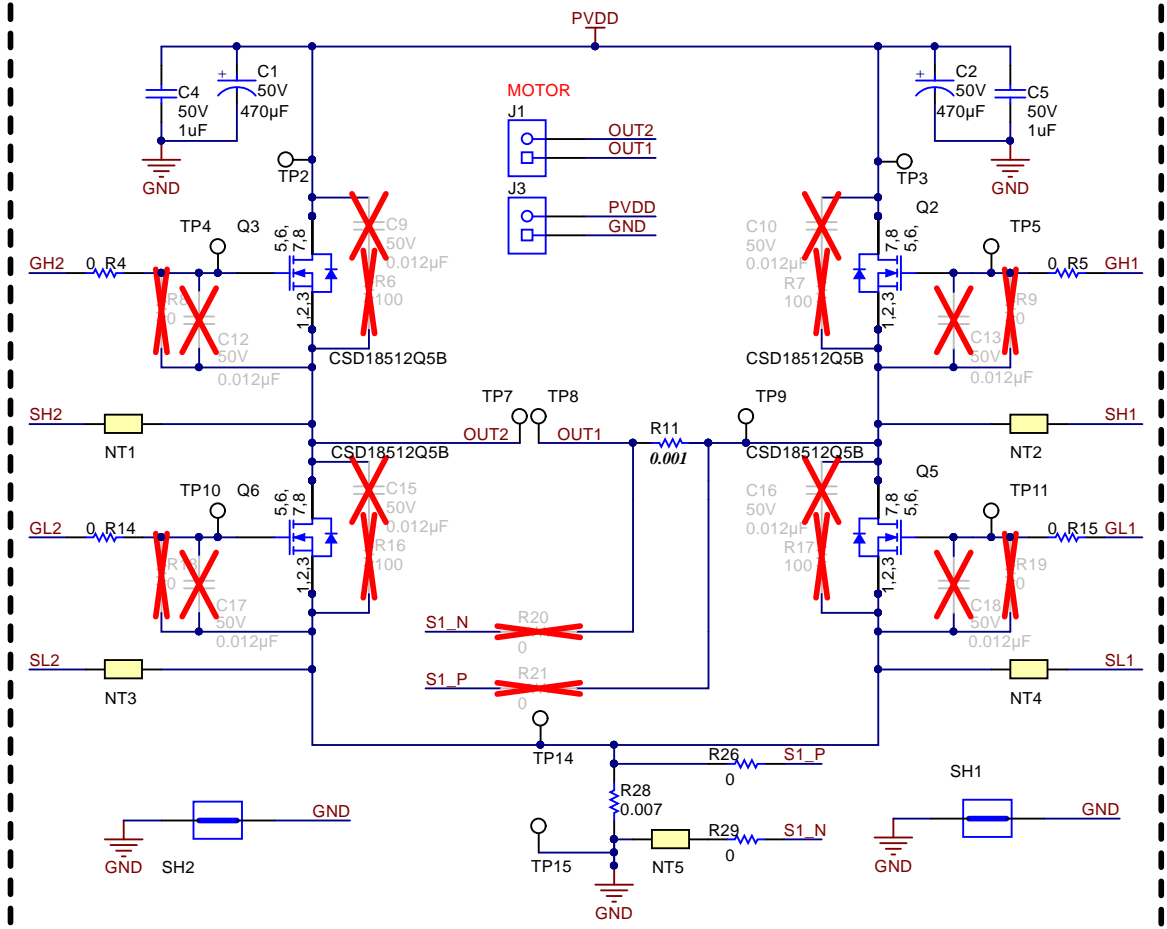

PI FILTER

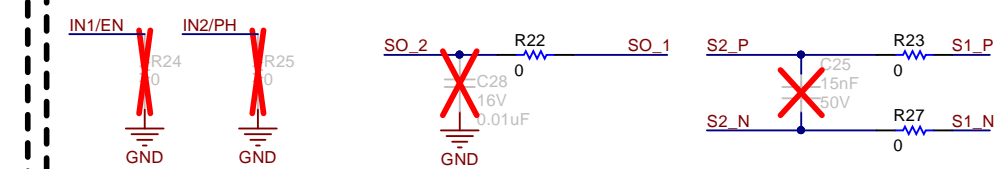
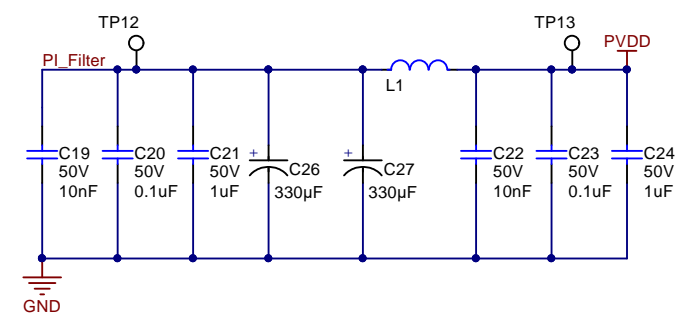

H VARIANT CONFIGURATION

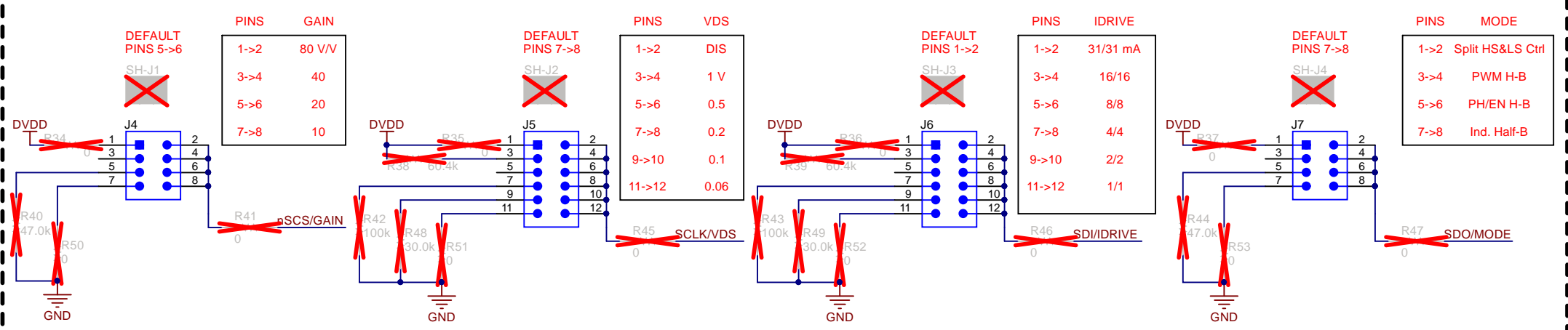

LEDS

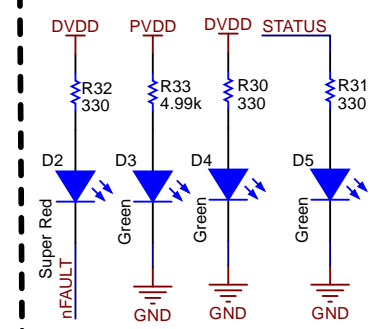

Texas Instruments and/or its licensors do not warrant the accuracy or completeness of this specification or any information contained therein. Texas Instruments and/or its licensors do not warrant that this design will meet the specifications, will be suitable for your application or fit for any particular purpose, or will operate in an implementation. Texas Instruments and/or its licensors do not warrant that the design is production worthy. You should completely validate and test your design implementation to confirm the system functionality for your application.

USB INTERFACE

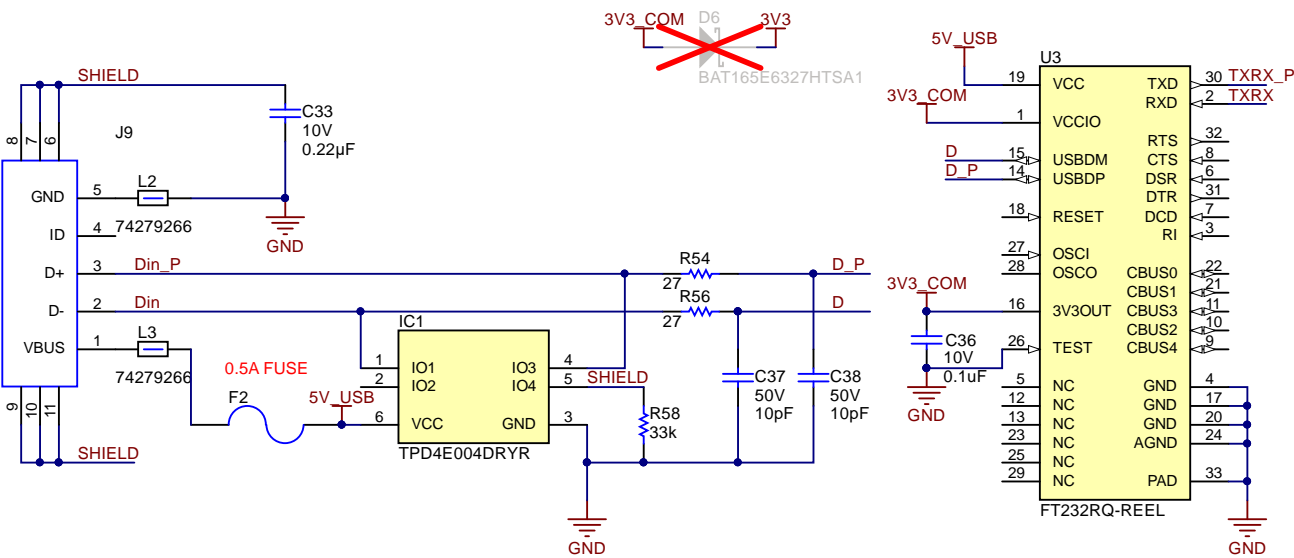

MSP430F2617

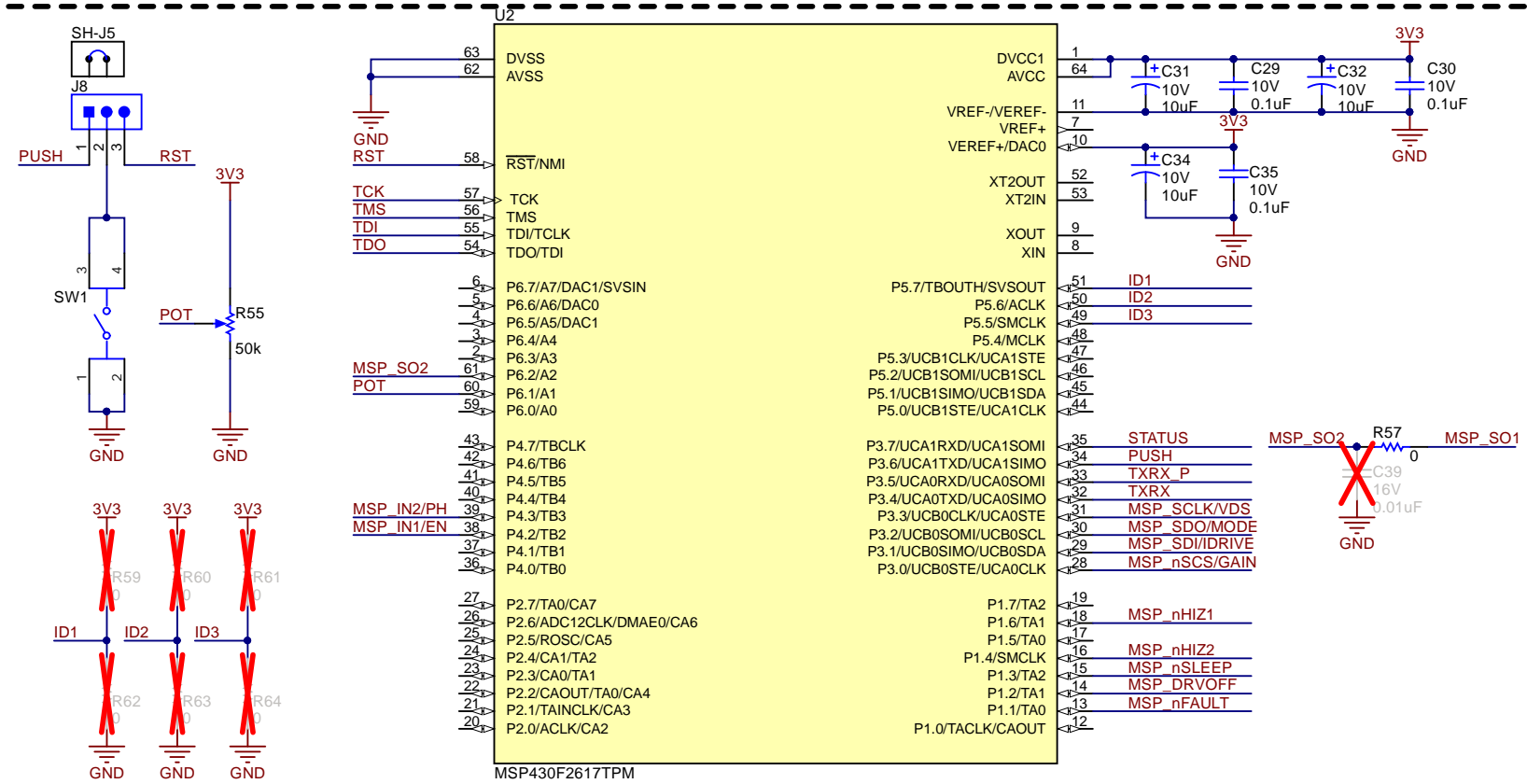

CONN's MSP430 TO DRV8x06x-Q1 OR DRV8705x-Q1

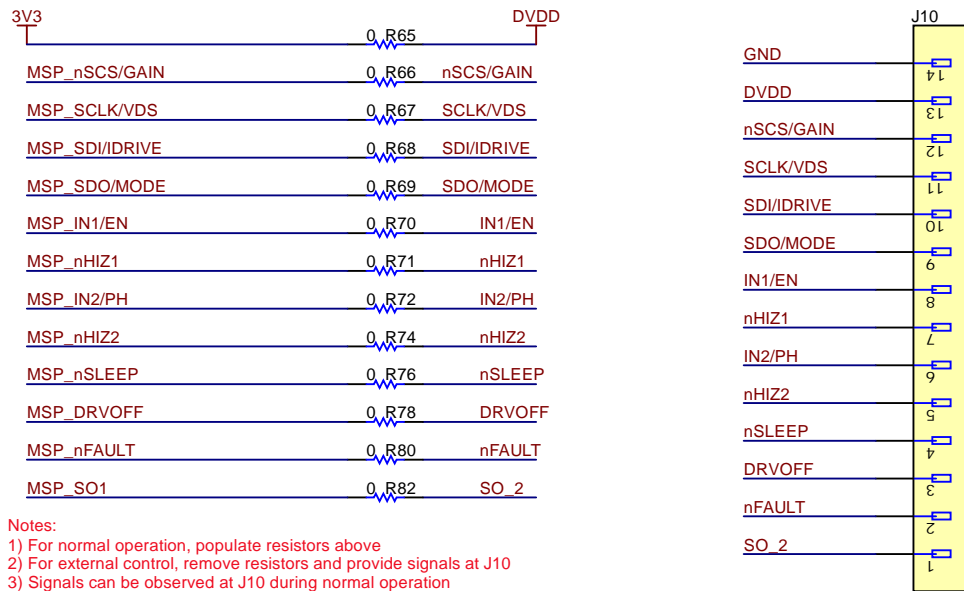

3V3 LDO

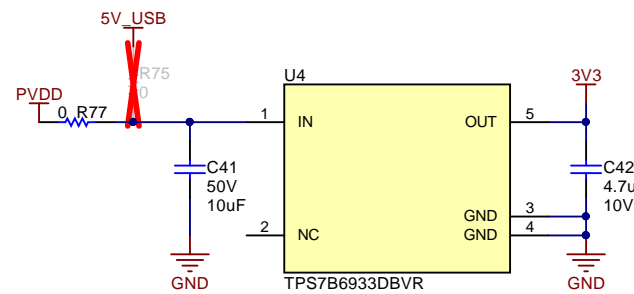

MSP-FET CONN

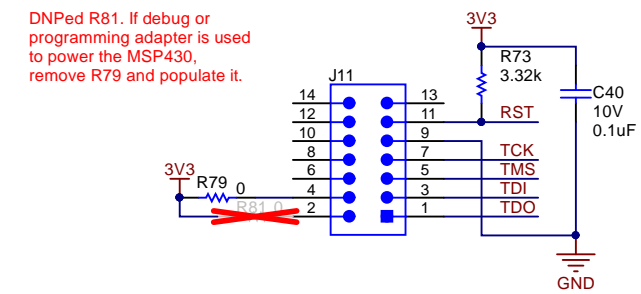

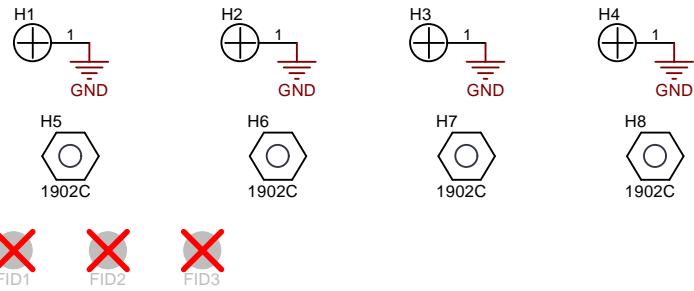

PCB Number: MD023
PCB Rev: E3

PCB LOGO
Texas Instruments

CE Mark

PCB LOGO
FCC disclaimer

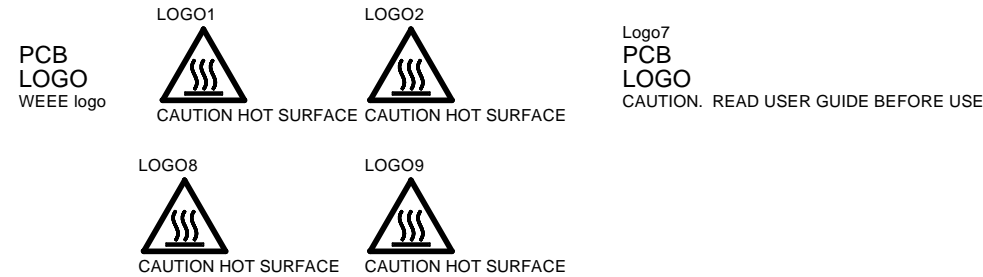

Variant/Label Table	
Variant	Label Text
001	DRV8706S-Q1EVM
003	DRV8106S-Q1EVM
005	DRV8705S-Q1EVM

H9
MECH
MechPart

LBL1
PCB Label
THT-14-423-10
Size: 0.65" x 0.20 "

ZZ1
Label Assembly Note
This Assembly Note is for PCB labels only

ZZ2
Assembly Note
These assemblies are ESD sensitive, ESD precautions shall be observed.

ZZ3
Assembly Note
These assemblies must be clean and free from flux and all contaminants. Use of no clean flux is not acceptable.

ZZ4
Assembly Note
These assemblies must comply with workmanship standards IPC-A-610 Class 2, unless otherwise specified.

Orderable: DRV8705S-Q1EVM	Designed for: Public Release	Mod. Date: 10/23/2019
TID #: N/A	Project Title: DRV8x06x-Q1EVMs & DRV8705x-Q1EVMs	
Number: MD023	Rev: E3	Sheet Title:
SVN Rev: Not in version control	Assembly Variant: 005	Sheet: 3 of 3
Drawn By:	File: MD023E3_Hardware.SchDoc	Size: B
Engineer: Hector Hernandez	Contact: http://www.ti.com/support	

Texas Instruments and/or its licensors do not warrant the accuracy or completeness of this specification or any information contained therein. Texas Instruments and/or its licensors do not warrant that this design will meet the specifications, will be suitable for your application or fit for any particular purpose, or will operate in an implementation. Texas Instruments and/or its licensors do not warrant that the design is production worthy. You should completely validate and test your design implementation to confirm the system functionality for your application.