

# MOTOR CONTROL INTERFACE TO DISPLAY BOARD

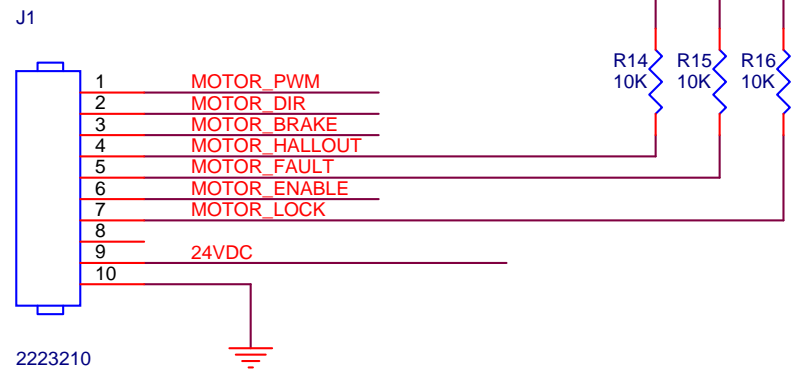

# HALL EFFECT SIGNALS

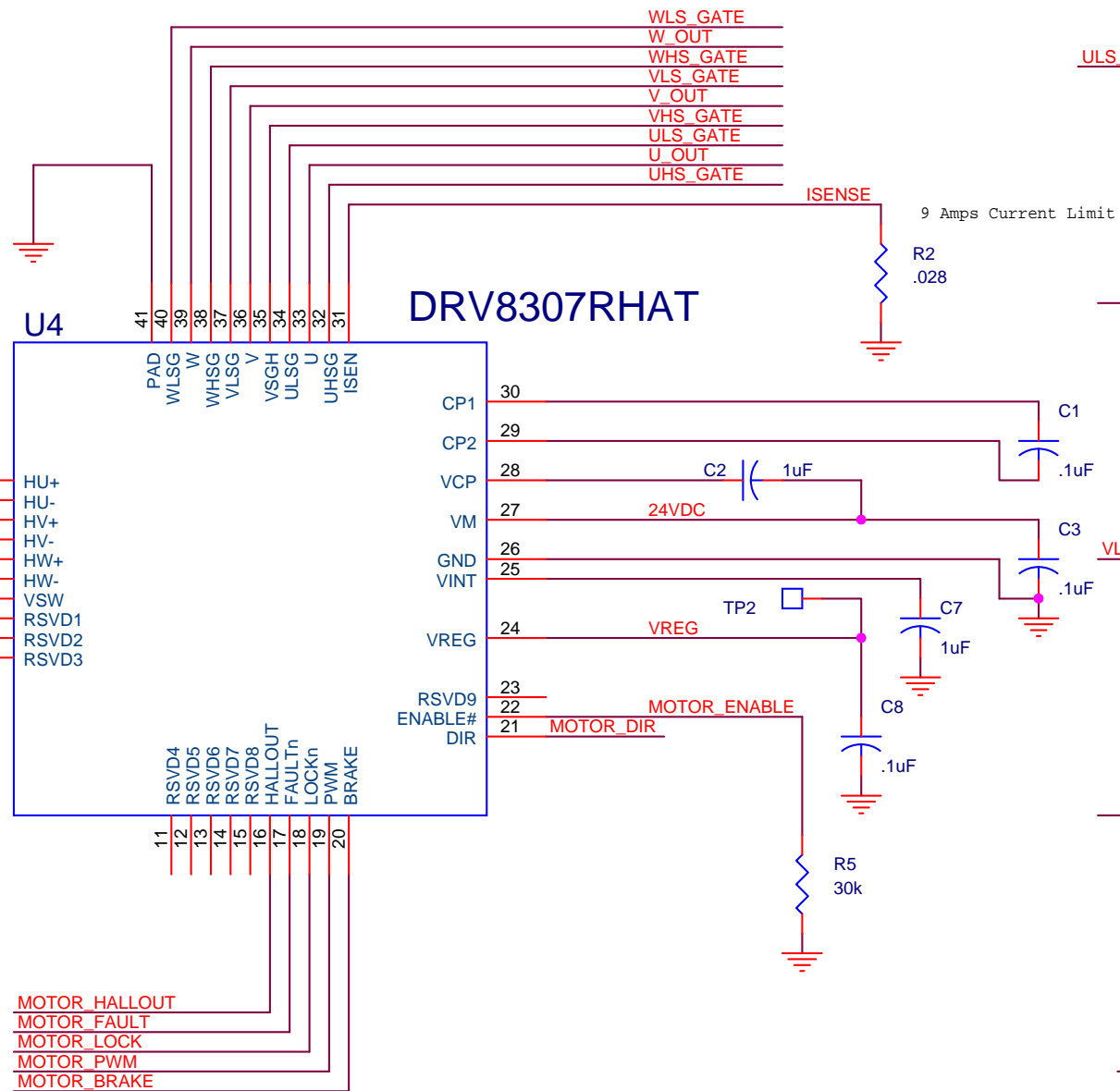
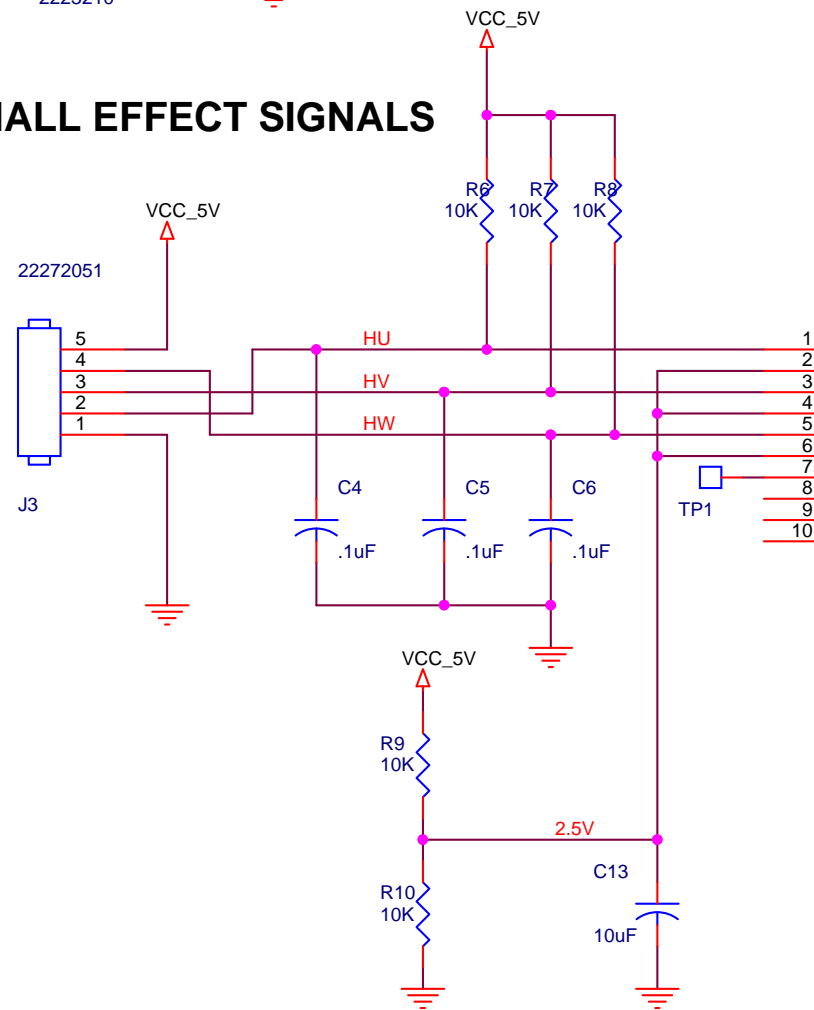

# INPUT POWER

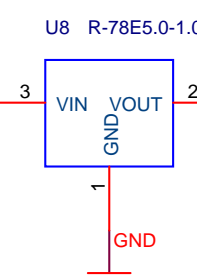
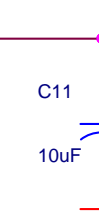
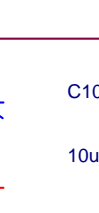
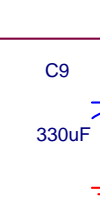
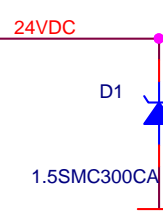
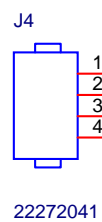

# +5V Regulator

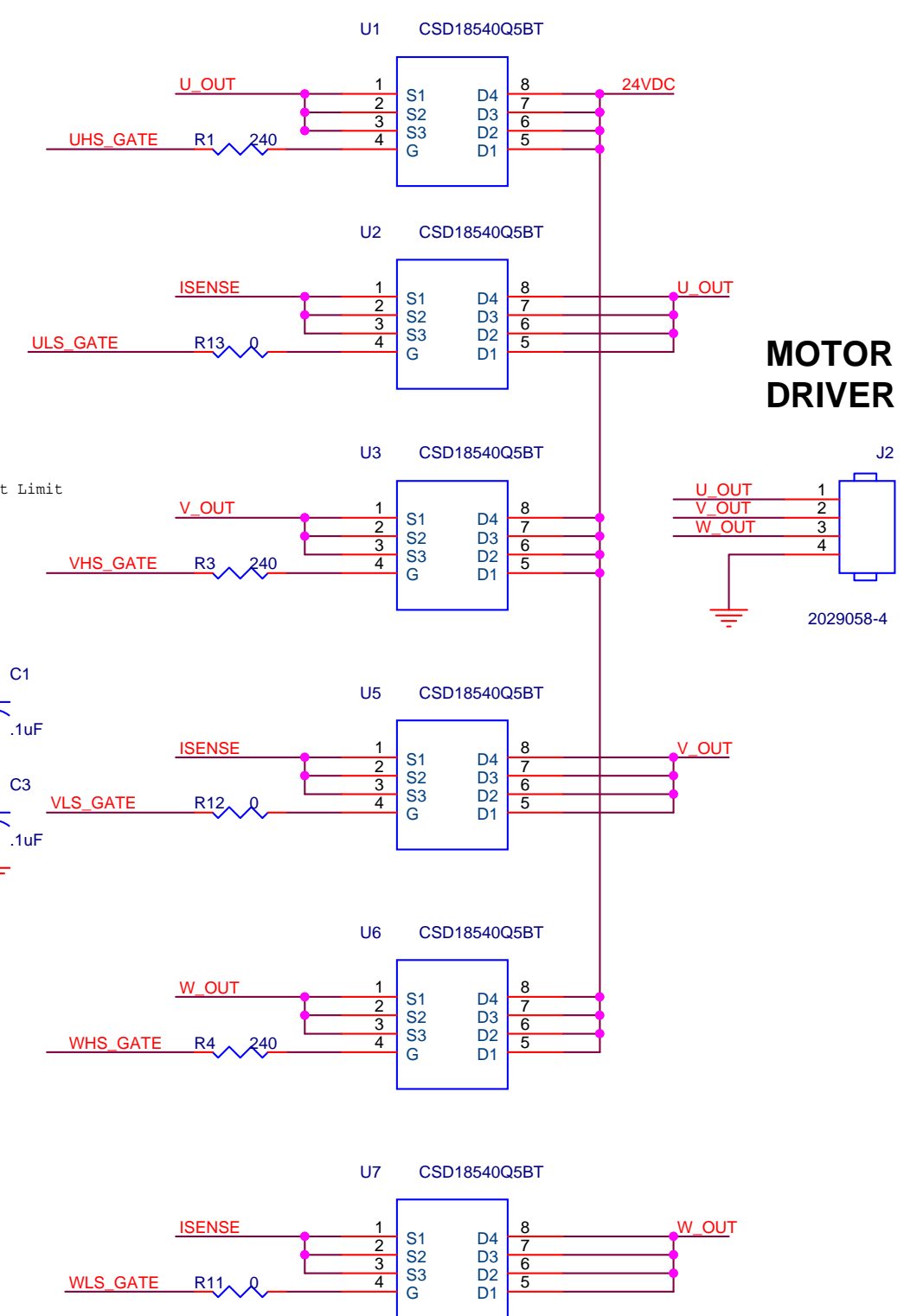

Title		
LW Scientific Motor Driver		
Size B	Document Number <Doc>	Rev B
Date:	Monday, January 30, 2017	Sheet 1 of 1