

Comparism new DRV8818 vs legacy A3977 MotorDriver

New MainBoard: Off Time is Prior to Step → leads into Jitter
 TI DRV8818

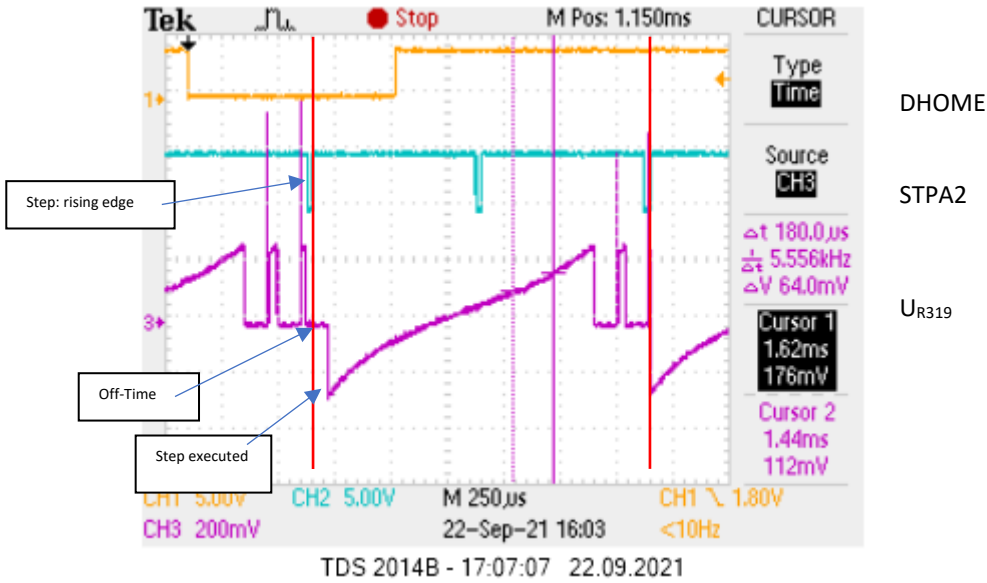

Legacy MainBoard: Step is Prior to Off Time → constant rotation
 Allegro A3977

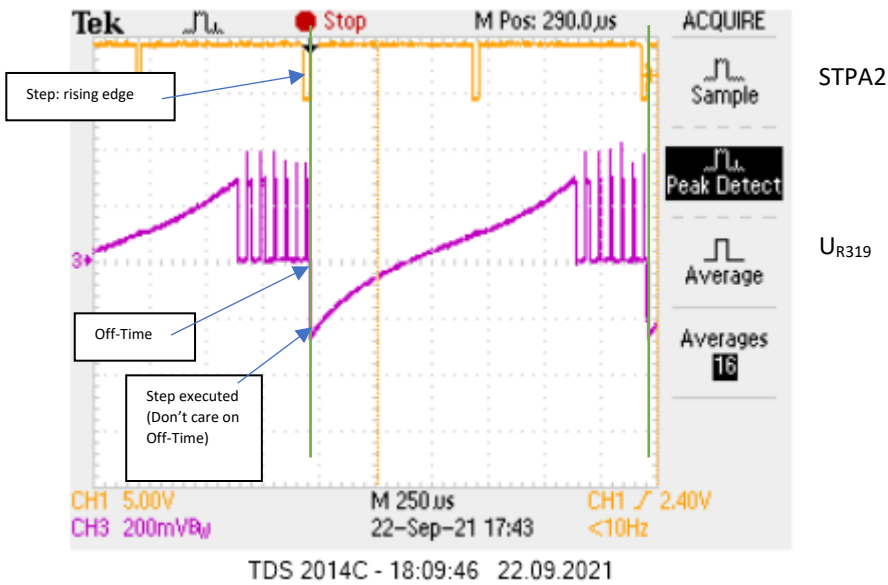

Workaround

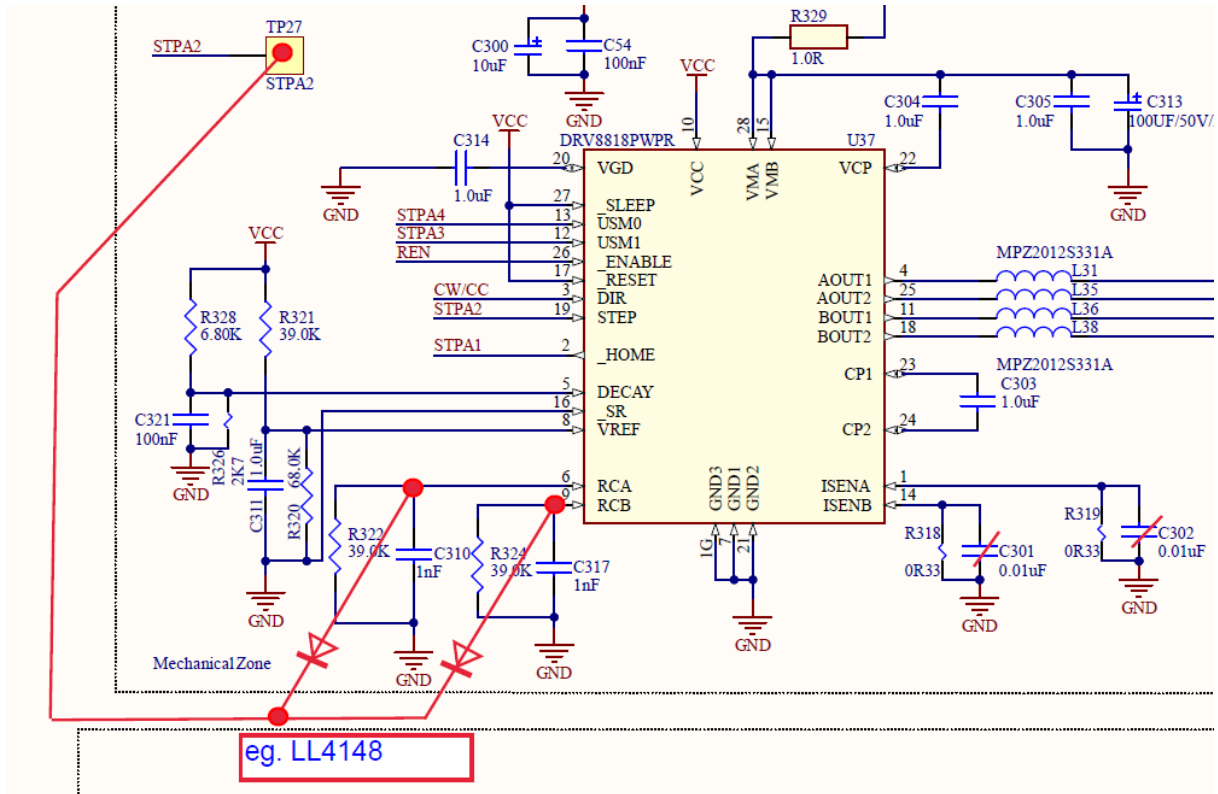

DRAFT. On my desk it works