

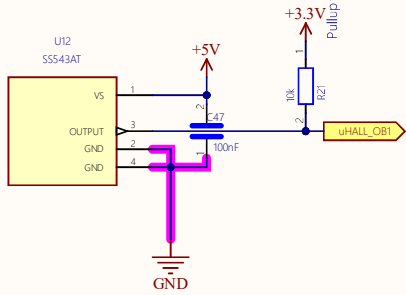

### Hall Sensors for RPM

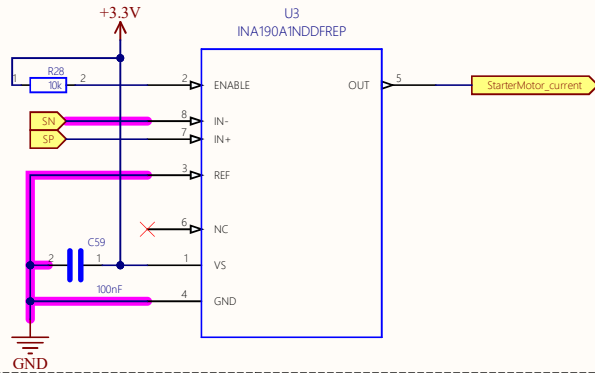

### Starter Motor Current Measurement unit



### Pressure V-limiter

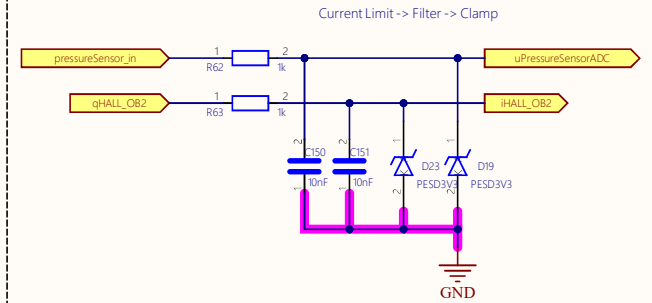

### CAN Transceivers

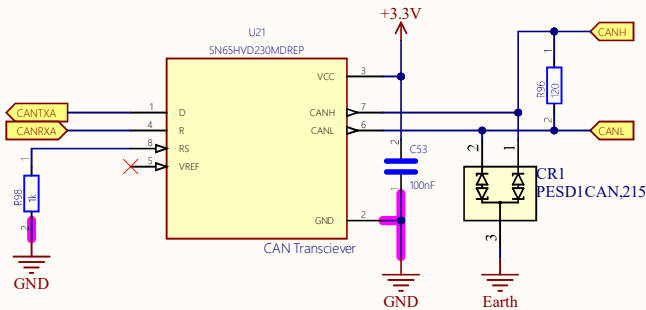

### DC Rails Voltage measurement

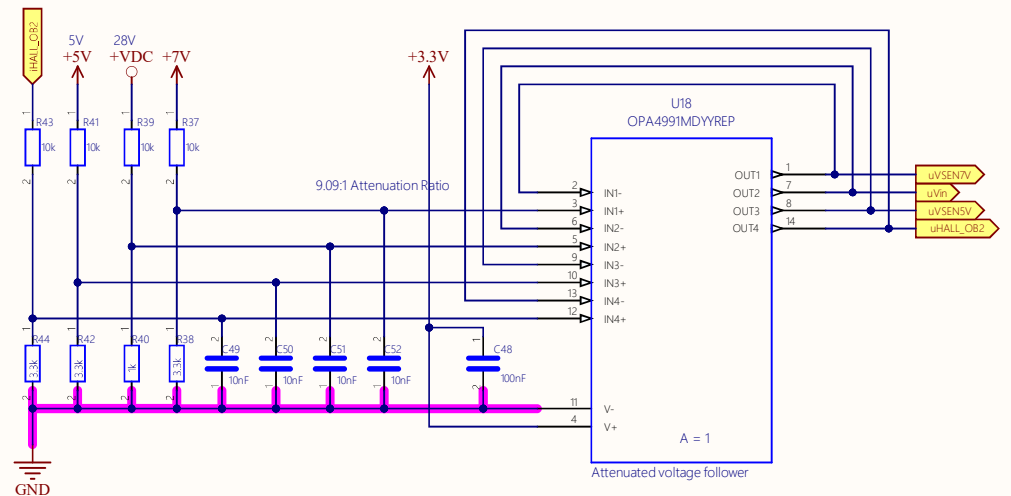

**Klok Systems**  
Excellence Delivered

Author: Anubhav Mukherjee  
Klok Systems Private Limited  
Sheet: /  
File: SensorInputs\_Altium\_sch

Engine Control Unit -- Sensors & Feedback Circuits

Title:		14-APRIL-2025	02A
Size: A4	11/20/2025	Rev:02	*