

PCIe 100M CLOCK DISTRIBUTION

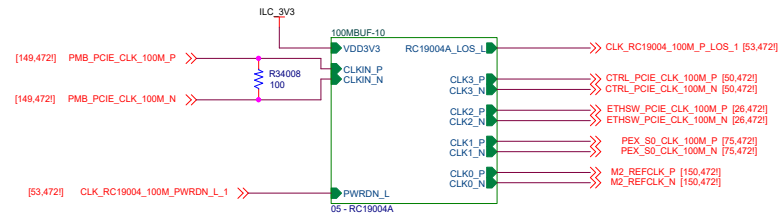

312.5M CLOCK DISTRIBUTION

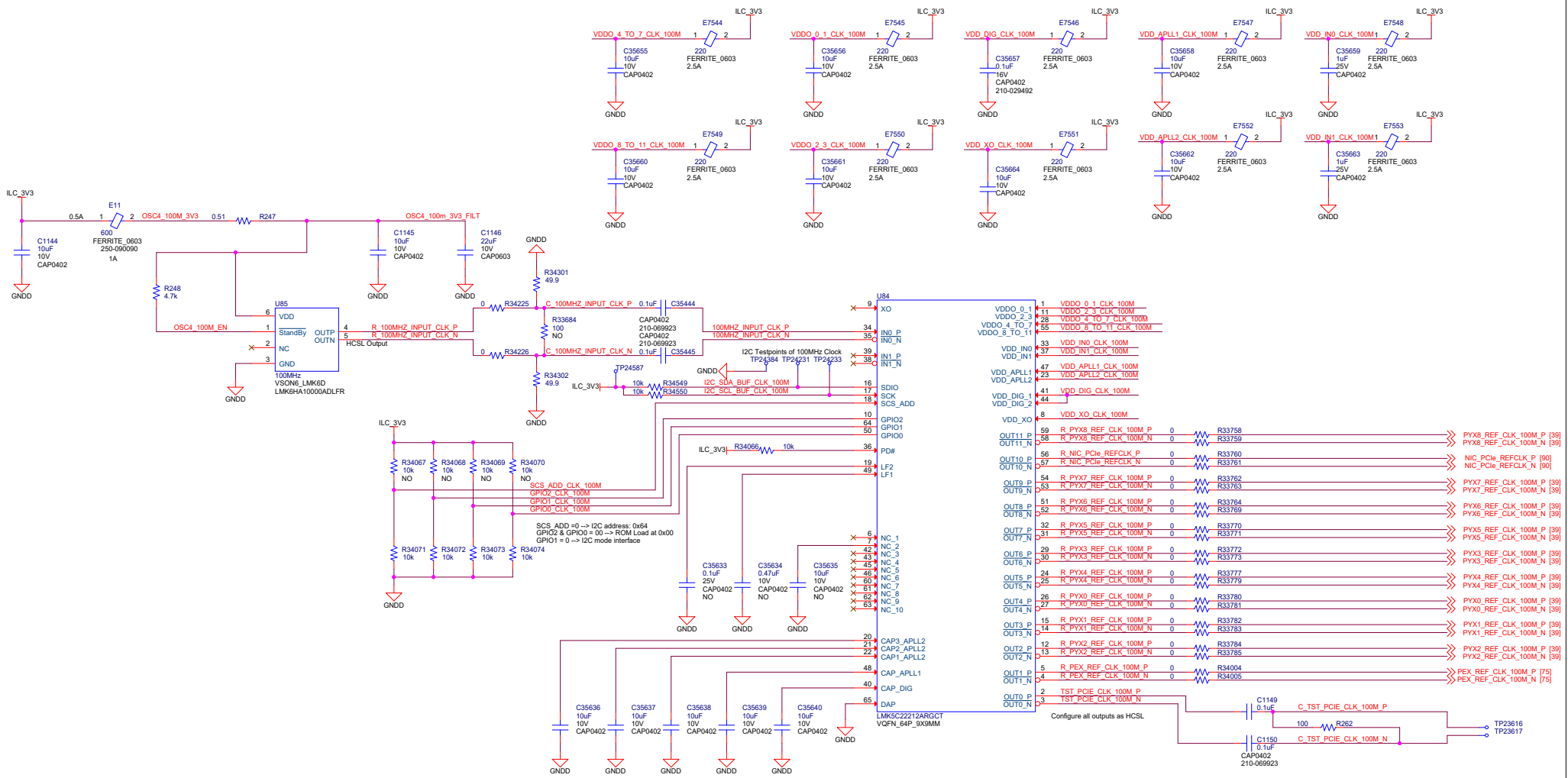
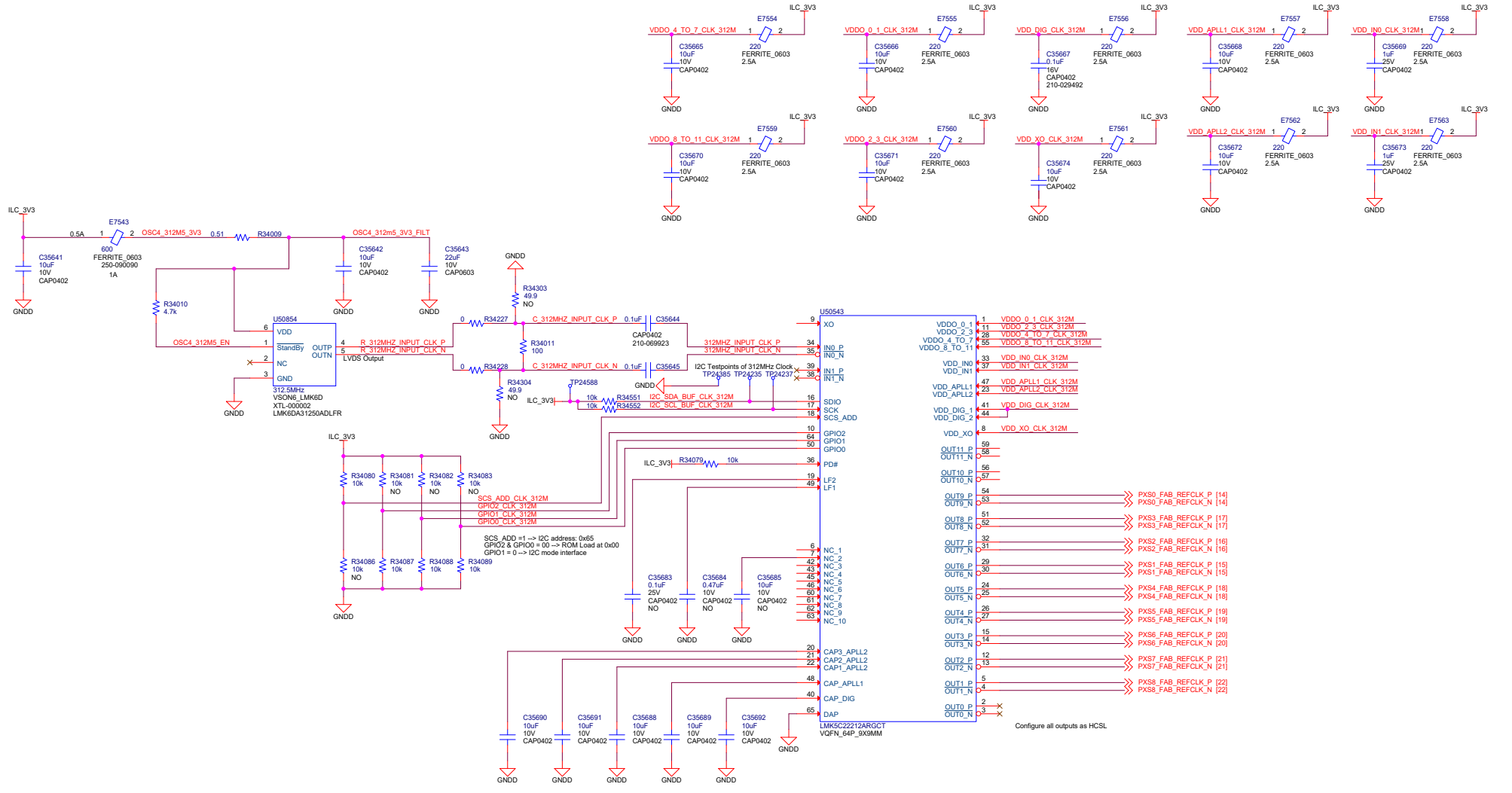

Configure all outputs as HCSL

PROJECT PYXIS TEST CARD		SECTION 312.5MHZ CLOCK	
recogni	PART NO.	SCH-186765	DATE
	CONFIDENTIAL © COPYRIGHT 2025 RECOGNI INC. ALL RIGHTS RESERVED.		REV
		01	ENG
		PAGE 38	OF 550