

NB3N511

PLL Clock Multiplier, 14 MHz - 200 MHz, 3.3 V / 5.0 V



ON Semiconductor®

www.onsemi.com

Description

The NB3N511 is a clock multiplier that will generate one of nine selectable output multiples of an input frequency via two 3-level select inputs (S0, S1). It accepts a standard fundamental mode crystal or an external reference clock signal. Phase-Locked-Loop (PLL) design techniques are used to produce a low jitter, TTL level clock output up to 200 MHz with a 50% duty cycle. An Output Enable (OE) pin is provided, and when asserted low, the clock output goes into tri-state (high impedance). The NB3N511 is commonly used in electronic systems as a cost efficient replacement for crystal oscillators.

Features

- Clock Output Frequencies up to 200 MHz
- Nine Selectable Multipliers of the Input Frequency
- Operating Range: $V_{DD} = 3.3\text{ V} \pm 10\%$ or $5.0\text{ V} \pm 5\%$
- Low Jitter Output of 25 ps One Sigma (rms)
- Zero ppm Clock Multiplication Error
- 45% - 55% Output Duty Cycle
- TTL/CMOS Output with 25 mA TTL Level Drive
- Crystal Reference Input Range of 5 - 32 MHz
- Input Clock Frequency Range of 1 - 50 MHz
- OE, Output Enable with Tri-State Output
- 8-Pin SOIC
- Industrial Temperature Range -40°C to $+85^{\circ}\text{C}$
- These are Pb-Free Devices

MARKING DIAGRAM

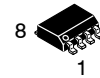

SOIC-8
D SUFFIX
CASE 751

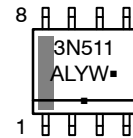

3N511 = Specific Device Code
A = Assembly Location
L = Wafer Lot
Y = Year
W = Work Week
▪ = Pb-Free Package

ORDERING INFORMATION

See detailed ordering and shipping information in the package dimensions section on page 5 of this data sheet.

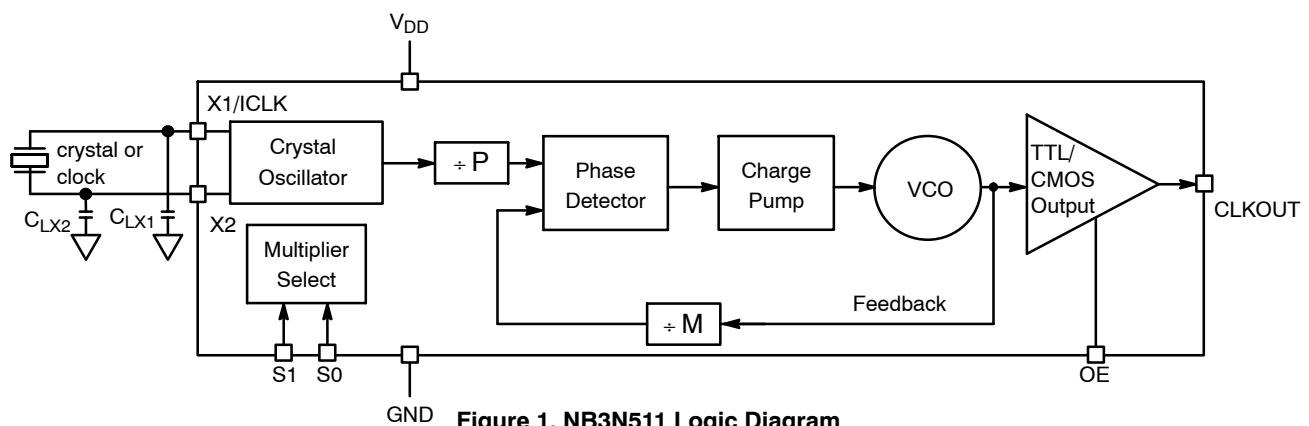

Figure 1. NB3N511 Logic Diagram

NB3N511

Table 1. CLOCK MULTIPLIER SELECT TABLE

S1*	S0*	CLKOUT Multiplier
L	L	4X Input
L	M	5.333X Input
L	H	5X Input
M	L	2.5X Input
M	M	2X Input
M	H	3.333X Input
H	L	6X Input
H	M	3X Input
H	H	8X Input

*Pins S1 and S0 default to M when open
 L = GND
 H = VDD
 M = OPEN (unconnected; will default to VDD/2)

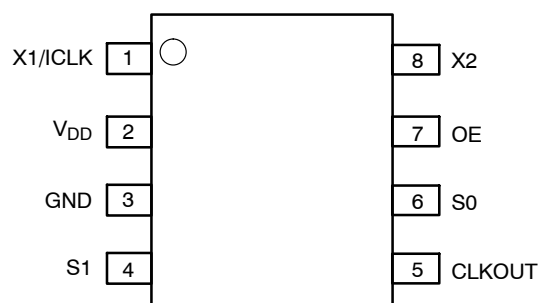

Figure 2. NB3N511 Package Pinout, 8-Pin (150 mil) SOIC (Top View)

Table 2. PIN DESCRIPTION

Pin #	Name	I/O	Description
1	X1/ICLK	Crystal or LVC MOS/LVTTL Input	Crystal or external reference clock input
2	VDD	Power supply	Positive supply voltage
3	GND	Power supply	0 V. Ground.
4	S1	Three level Input	Multiplier select pin – connect to V _{DD} , GND or float
5	CLKOUT	LVC MOS/LVTTL Output	Clock output
6	S0	Three level Input	Multiplier select pin – connect to V _{DD} , GND or float
7	OE	LVC MOS/LVTTL Input	Output Enable. CLKOUT is high impedance when OE is low. Internal pullup
8	X2	Crystal	Crystal input – Leave open when providing an external clock reference

Table 3. COMMON OUTPUT FREQUENCY EXAMPLES

Output Frequency (MHz)	Input Frequency (MHz)	S1, S0
20	10	M, M
24	12	M, M
30	10	H, M
32	16	M, M
33.33	16.66	M, M
37.5	15	M, L
40	10	L, L
48	12	L, L
50	20	M, L
60	10	H, L
64	16	L, L

Table 4. COMMON OUTPUT FREQUENCY EXAMPLES

Output Frequency (MHz)	Input Frequency (MHz)	S1, S0
66.66	20	M, H
72	12	H, L
75	25	H, M
80	10	H, H
83.33	25	M, H
90	15	H, L
100	20	L, H
120	15	H, H
125	25	L, H
133.3	25	L, M
150	25	H, L

NB3N511

Table 4. ATTRIBUTES

Characteristics		Value
ESD Protection	Human Body Model	> 1 kV
	Machine Model	> 150 V
	Charged Device Model	> 1 kV
RPU – OE Input Pull-up Resistor		270 kΩ
Moisture Sensitivity (Note 1)	SOIC-8	Level 1
Flammability Rating	Oxygen Index: 28 to 34	UL 94 V 0 @ 0.125 in
Transistor Count		9555
Meets or exceeds JEDEC Spec EIA/JESD78 IC Latchup Test		

1. For additional information, see Application Note AND8003/D.

Table 5. MAXIMUM RATINGS

Symbol	Parameter	Condition 1	Condition 2	Rating	Unit
V_{DD}	Positive Power Supply	GND = 0 V		7	V
V_{IO}	Input and Output Voltages			$-0.5\text{ V} \leq V_{IO} \leq V_{DD} + 0.5$	V
T_A	Operating Temperature Range			-40 to +85	°C
T_{stg}	Storage Temperature Range			-65 to +150	°C
θ_{JA}	Thermal Resistance (Junction-to-Ambient)	0 lfpm	SOIC-8	190	°C/W
		500 lfpm	SOIC-8	130	
θ_{JC}	Thermal Resistance (Junction-to-Case)	(Note 2)	SOIC-8	41 to 44	°C/W
T_{sol}	Wave Solder	Pb-Free		265	°C

Stresses exceeding those listed in the Maximum Ratings table may damage the device. If any of these limits are exceeded, device functionality should not be assumed, damage may occur and reliability may be affected.

2. JEDEC standard multilayer board – 2S2P (2 signal, 2 power) with 8 filled thermal vias under exposed pad.

NB3N511

Table 6. DC CHARACTERISTICS $V_{DD} = 3.3\text{ V} \pm 10\%$ or $5.0\text{ V} \pm 5\%$ unless otherwise noted, $GND = 0\text{ V}$, $T_A = -40^\circ\text{C}$ to $+85^\circ\text{C}$

Symbol	Characteristic	Min	Typ	Max	Unit
V_{DD}	Operating Voltage $V_{DD} = 5\text{ V}$ $V_{DD} = 3.3\text{ V}$	4.75 3.0		5.25 3.6	V
I_{DD}	Power Supply Current – Inputs and outputs open, CLKOUT operating at 100 MHz (with 20 MHz crystal) $V_{DD} = 5\text{ V}$ $V_{DD} = 3.3\text{ V}$		9 8		mA
V_{OH}	Output HIGH Voltage $I_{OH} = -4\text{ mA}$ CMOS High	$V_{DD} - 0.4$			V
V_{OH}	Output HIGH Voltage $I_{OH} = -25\text{ mA}$ TTL High	2.4			V
V_{OL}	Output LOW Voltage $I_{OL} = 25\text{ mA}$			0.4	V
V_{IH}	Input HIGH Voltage, ICLK only (pin 1) $V_{DD} = 5\text{ V}$ $V_{DD} = 3.3\text{ V}$	$(V_{DD}/2) + 1$ $(V_{DD}/2) + 0.7$			V
V_{IL}	Input LOW Voltage, ICLK only (pin 1) $V_{DD} = 5\text{ V}$ $V_{DD} = 3.3\text{ V}$			$(V_{DD}/2) - 1$ $(V_{DD}/2) - 0.7$	V
V_{IH}	Input HIGH Voltage, S0, S1	$V_{DD} - 0.5$			V
V_{IL}	Input LOW Voltage, S0, S1			0.5	V
V_{IH}	Input HIGH Voltage, OE (pin 7)	2.0			V
V_{IL}	Input LOW Voltage, OE (pin 7)			0.8	V
C_{in}	Input Capacitance, S0, S1 and OE		4		pF
I_{SC}	Output Short Circuit Current, CLKOUT		± 70		mA
	Nominal Output Impedance		20		Ω

Table 7. AC CHARACTERISTICS $V_{DD} = 3.3\text{ V} \pm 10\%$ or $5.0\text{ V} \pm 5\%$ unless otherwise noted, $GND = 0\text{ V}$, $T_A = -40^\circ\text{C}$ to $+85^\circ\text{C}$

Symbol	Characteristic	Min	Typ	Max	Unit
f_{Xtal}	Crystal Input Frequency (Note 3)	5		32	MHz
f_{CLKIN}	Clock Input Frequency	1		50	MHz
f_{OUT}	Output Frequency Range $f_{OUTMIN} \leq f_{IN} \times \text{Multiplier} \leq f_{OUTMAX}$ $V_{DD} = 4.25\text{ to }5.25\text{ V} (5.0\text{ V} \pm 5\%)$ $V_{DD} = 3.0\text{ to }3.6\text{ V} (3.3\text{ V} \pm 10\%)$	4 4		200 200	MHz
DC	Output Clock Duty Cycle at 1.5 V	45	50	55	%
OE_H	Output enable time, OE high to output on		50		ns
OE_L	Output disable time, OE low to tri-state		50		ns
$t_{jitter (rms)}$	Period Jitter (rms, 1 σ)		25		ps
$t_{jitter (pk-to-pk)}$	Total Period Jitter, (peak-to-peak)		± 70		ps
t_r/t_f	Output rise/fall time (0.8 V to 2.0 V) (measured with 15 pF load)		1	1.5	ns

3. The crystal should be fundamental mode, parallel resonant. Do not use third overtone. For exact tuning when using a crystal, capacitors should be connected from pins X1/CLK to GND and X2 to GND. The value of these capacitors is given by the following equation, where C_L is the specified crystal load capacitance: Crystal capacitance (pF) = $(C_L - 12) \times 2$. So, for a crystal with 16 pF load capacitance, use two 8 pF capacitors.

APPLICATIONS INFORMATION

High Frequency CMOS/TTL Oscillators

The NB3N511, along with a low frequency fundamental mode crystal, can build a high frequency TTL output oscillator. For example, a 20 MHz crystal connected to the NB3N511 with the 5X output selected (S1 = L, S0 = H) produces an 100 MHz CMOS/TTL output clock.

Decoupling and External Components

The NB3N511 requires a 0.01 μF decoupling capacitor to be connected between V_{DD} and GND on pins 2 and 3. It must be connected close to the NB3N511 to minimize lead inductance. Control input pins can be connected to device pins V_{DD} or GND, or to the V_{DD} and GND planes on the board.

Series Termination Resistor

A 33 Ω terminating resistor can be used next to the CLK pin for trace lengths over one inch.

Crystal Information

The crystal used should be a fundamental mode (do not use third overtone), parallel resonant. Crystal load capacitors should be connected from pins X1 to ground and X2 to ground to optimize the frequency accuracy, See Figure 1.

The total on chip capacitance is approximately 12 pF. A parallel resonant, fundamental mode crystal should be used. The device crystal connections should include pads for

small capacitors from X1 to ground and from X2 to ground. These capacitors are used to adjust the stray capacitance of the board to match the nominally required crystal load capacitance. Because load capacitance can only be increased in this trimming process, it is important to keep stray capacitance to a minimum by using very short PCB traces (and no vias) between the crystal and device. Crystal capacitors, if needed, must be connected from each of the pins X1 and X2 to ground. The value (in pF) of these crystal caps should equal $(C_L - 12 \text{ pF}) * 2$. In this equation, C_L = crystal load capacitance in pF. Example: For a crystal with a 16 pF load capacitance, each crystal capacitor would be 8 pF $[(16 - 12) * 2 = 8]$.

Table 8. RECOMMENDED CRYSTAL PARAMETERS

Parameter	Value
Crystal Cut	Fundamental AT Cut
Resonance	Parallel Resonance
Load Capacitance	18 pF
Operating Range	-40 to +85°C
Shunt Capacitance	5 pF Max
Equivalent Series Resistance (ESR)	50 Ω Max
Correlation Drive Level	1.0 mW Max

ORDERING INFORMATION

Device	Package	Shipping†
NB3N511DG	SOIC-8 (Pb-Free)	98 Units / Rail
NB3N511DR2G	SOIC-8 (Pb-Free)	2500 / Tape & Reel

†For information on tape and reel specifications, including part orientation and tape sizes, please refer to our Tape and Reel Packaging Specifications Brochure, BRD8011/D.

MECHANICAL CASE OUTLINE PACKAGE DIMENSIONS

ON Semiconductor®



SCALE 1:1

SOIC-8 NB
CASE 751-07
ISSUE AK

DATE 16 FEB 2011



- NOTES:
1. DIMENSIONING AND TOLERANCING PER ANSI Y14.5M, 1982.
 2. CONTROLLING DIMENSION: MILLIMETER.
 3. DIMENSION A AND B DO NOT INCLUDE MOLD PROTRUSION.
 4. MAXIMUM MOLD PROTRUSION 0.15 (0.006) PER SIDE.
 5. DIMENSION D DOES NOT INCLUDE DAMBAR PROTRUSION. ALLOWABLE DAMBAR PROTRUSION SHALL BE 0.127 (0.005) TOTAL IN EXCESS OF THE D DIMENSION AT MAXIMUM MATERIAL CONDITION.
 6. 751-01 THRU 751-06 ARE OBSOLETE. NEW STANDARD IS 751-07.

DIM	MILLIMETERS		INCHES	
	MIN	MAX	MIN	MAX
A	4.80	5.00	0.189	0.197
B	3.80	4.00	0.150	0.157
C	1.35	1.75	0.053	0.069
D	0.33	0.51	0.013	0.020
G	1.27 BSC		0.050 BSC	
H	0.10	0.25	0.004	0.010
J	0.19	0.25	0.007	0.010
K	0.40	1.27	0.016	0.050
M	0°	8°	0°	8°
N	0.25	0.50	0.010	0.020
S	5.80	6.20	0.228	0.244

SOLDERING FOOTPRINT*



*For additional information on our Pb-Free strategy and soldering details, please download the ON Semiconductor Soldering and Mounting Techniques Reference Manual, SOLDERRM/D.

GENERIC MARKING DIAGRAM*

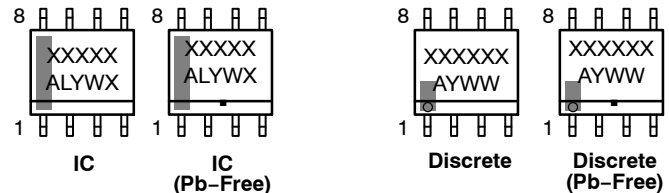

XXXXXX = Specific Device Code
 A = Assembly Location
 L = Wafer Lot
 Y = Year
 W = Work Week
 ■ = Pb-Free Package

XXXXXX = Specific Device Code
 A = Assembly Location
 Y = Year
 WW = Work Week
 ■ = Pb-Free Package

*This information is generic. Please refer to device data sheet for actual part marking. Pb-Free indicator, "G" or microdot "•", may or may not be present. Some products may not follow the Generic Marking.

STYLES ON PAGE 2

DOCUMENT NUMBER:	98ASB42564B	Electronic versions are uncontrolled except when accessed directly from the Document Repository. Printed versions are uncontrolled except when stamped "CONTROLLED COPY" in red.
DESCRIPTION:	SOIC-8 NB	PAGE 1 OF 2

ON Semiconductor and ON are trademarks of Semiconductor Components Industries, LLC dba ON Semiconductor or its subsidiaries in the United States and/or other countries. ON Semiconductor reserves the right to make changes without further notice to any products herein. ON Semiconductor makes no warranty, representation or guarantee regarding the suitability of its products for any particular purpose, nor does ON Semiconductor assume any liability arising out of the application or use of any product or circuit, and specifically disclaims any and all liability, including without limitation special, consequential or incidental damages. ON Semiconductor does not convey any license under its patent rights nor the rights of others.

SOIC-8 NB
CASE 751-07
ISSUE AK

DATE 16 FEB 2011

- | | | | |
|--|---|---|---|
| <p>STYLE 1:
 PIN 1. EMITTER
 2. COLLECTOR
 3. COLLECTOR
 4. EMITTER
 5. EMITTER
 6. BASE
 7. BASE
 8. EMITTER</p> | <p>STYLE 2:
 PIN 1. COLLECTOR, DIE, #1
 2. COLLECTOR, #1
 3. COLLECTOR, #2
 4. COLLECTOR, #2
 5. BASE, #2
 6. EMITTER, #2
 7. BASE, #1
 8. EMITTER, #1</p> | <p>STYLE 3:
 PIN 1. DRAIN, DIE #1
 2. DRAIN, #1
 3. DRAIN, #2
 4. DRAIN, #2
 5. GATE, #2
 6. SOURCE, #2
 7. GATE, #1
 8. SOURCE, #1</p> | <p>STYLE 4:
 PIN 1. ANODE
 2. ANODE
 3. ANODE
 4. ANODE
 5. ANODE
 6. ANODE
 7. ANODE
 8. COMMON CATHODE</p> |
| <p>STYLE 5:
 PIN 1. DRAIN
 2. DRAIN
 3. DRAIN
 4. DRAIN
 5. GATE
 6. GATE
 7. SOURCE
 8. SOURCE</p> | <p>STYLE 6:
 PIN 1. SOURCE
 2. DRAIN
 3. DRAIN
 4. SOURCE
 5. SOURCE
 6. GATE
 7. GATE
 8. SOURCE</p> | <p>STYLE 7:
 PIN 1. INPUT
 2. EXTERNAL BYPASS
 3. THIRD STAGE SOURCE
 4. GROUND
 5. DRAIN
 6. GATE 3
 7. SECOND STAGE Vd
 8. FIRST STAGE Vd</p> | <p>STYLE 8:
 PIN 1. COLLECTOR, DIE #1
 2. BASE, #1
 3. BASE, #2
 4. COLLECTOR, #2
 5. COLLECTOR, #2
 6. EMITTER, #2
 7. EMITTER, #1
 8. COLLECTOR, #1</p> |
| <p>STYLE 9:
 PIN 1. EMITTER, COMMON
 2. COLLECTOR, DIE #1
 3. COLLECTOR, DIE #2
 4. EMITTER, COMMON
 5. EMITTER, COMMON
 6. BASE, DIE #2
 7. BASE, DIE #1
 8. EMITTER, COMMON</p> | <p>STYLE 10:
 PIN 1. GROUND
 2. BIAS 1
 3. OUTPUT
 4. GROUND
 5. GROUND
 6. BIAS 2
 7. INPUT
 8. GROUND</p> | <p>STYLE 11:
 PIN 1. SOURCE 1
 2. GATE 1
 3. SOURCE 2
 4. GATE 2
 5. DRAIN 2
 6. DRAIN 2
 7. DRAIN 1
 8. DRAIN 1</p> | <p>STYLE 12:
 PIN 1. SOURCE
 2. SOURCE
 3. SOURCE
 4. GATE
 5. DRAIN
 6. DRAIN
 7. DRAIN
 8. DRAIN</p> |
| <p>STYLE 13:
 PIN 1. N.C.
 2. SOURCE
 3. SOURCE
 4. GATE
 5. DRAIN
 6. DRAIN
 7. DRAIN
 8. DRAIN</p> | <p>STYLE 14:
 PIN 1. N-SOURCE
 2. N-GATE
 3. P-SOURCE
 4. P-GATE
 5. P-DRAIN
 6. P-DRAIN
 7. N-DRAIN
 8. N-DRAIN</p> | <p>STYLE 15:
 PIN 1. ANODE 1
 2. ANODE 1
 3. ANODE 1
 4. ANODE 1
 5. CATHODE, COMMON
 6. CATHODE, COMMON
 7. CATHODE, COMMON
 8. CATHODE, COMMON</p> | <p>STYLE 16:
 PIN 1. EMITTER, DIE #1
 2. BASE, DIE #1
 3. EMITTER, DIE #2
 4. BASE, DIE #2
 5. COLLECTOR, DIE #2
 6. COLLECTOR, DIE #2
 7. COLLECTOR, DIE #1
 8. COLLECTOR, DIE #1</p> |
| <p>STYLE 17:
 PIN 1. VCC
 2. V2OUT
 3. V1OUT
 4. TXE
 5. RXE
 6. VEE
 7. GND
 8. ACC</p> | <p>STYLE 18:
 PIN 1. ANODE
 2. ANODE
 3. SOURCE
 4. GATE
 5. DRAIN
 6. DRAIN
 7. CATHODE
 8. CATHODE</p> | <p>STYLE 19:
 PIN 1. SOURCE 1
 2. GATE 1
 3. SOURCE 2
 4. GATE 2
 5. DRAIN 2
 6. MIRROR 2
 7. DRAIN 1
 8. MIRROR 1</p> | <p>STYLE 20:
 PIN 1. SOURCE (N)
 2. GATE (N)
 3. SOURCE (P)
 4. GATE (P)
 5. DRAIN
 6. DRAIN
 7. DRAIN
 8. DRAIN</p> |
| <p>STYLE 21:
 PIN 1. CATHODE 1
 2. CATHODE 2
 3. CATHODE 3
 4. CATHODE 4
 5. CATHODE 5
 6. COMMON ANODE
 7. COMMON ANODE
 8. CATHODE 6</p> | <p>STYLE 22:
 PIN 1. I/O LINE 1
 2. COMMON CATHODE/VCC
 3. COMMON CATHODE/VCC
 4. I/O LINE 3
 5. COMMON ANODE/GND
 6. I/O LINE 4
 7. I/O LINE 5
 8. COMMON ANODE/GND</p> | <p>STYLE 23:
 PIN 1. LINE 1 IN
 2. COMMON ANODE/GND
 3. COMMON ANODE/GND
 4. LINE 2 IN
 5. LINE 2 OUT
 6. COMMON ANODE/GND
 7. COMMON ANODE/GND
 8. LINE 1 OUT</p> | <p>STYLE 24:
 PIN 1. BASE
 2. EMITTER
 3. COLLECTOR/ANODE
 4. COLLECTOR/ANODE
 5. CATHODE
 6. CATHODE
 7. COLLECTOR/ANODE
 8. COLLECTOR/ANODE</p> |
| <p>STYLE 25:
 PIN 1. VIN
 2. N/C
 3. REXT
 4. GND
 5. IOUT
 6. IOUT
 7. IOUT
 8. IOUT</p> | <p>STYLE 26:
 PIN 1. GND
 2. dv/dt
 3. ENABLE
 4. ILIMIT
 5. SOURCE
 6. SOURCE
 7. SOURCE
 8. VCC</p> | <p>STYLE 27:
 PIN 1. ILIMIT
 2. OVLO
 3. UVLO
 4. INPUT+
 5. SOURCE
 6. SOURCE
 7. SOURCE
 8. DRAIN</p> | <p>STYLE 28:
 PIN 1. SW_TO_GND
 2. DASIC OFF
 3. DASIC_SW_DET
 4. GND
 5. V_MON
 6. VBULK
 7. VBULK
 8. VIN</p> |
| <p>STYLE 29:
 PIN 1. BASE, DIE #1
 2. EMITTER, #1
 3. BASE, #2
 4. EMITTER, #2
 5. COLLECTOR, #2
 6. COLLECTOR, #2
 7. COLLECTOR, #1
 8. COLLECTOR, #1</p> | <p>STYLE 30:
 PIN 1. DRAIN 1
 2. DRAIN 1
 3. GATE 2
 4. SOURCE 2
 5. SOURCE 1/DRAIN 2
 6. SOURCE 1/DRAIN 2
 7. SOURCE 1/DRAIN 2
 8. GATE 1</p> | | |

DOCUMENT NUMBER:	98ASB42564B	Electronic versions are uncontrolled except when accessed directly from the Document Repository. Printed versions are uncontrolled except when stamped "CONTROLLED COPY" in red.
DESCRIPTION:	SOIC-8 NB	PAGE 2 OF 2

ON Semiconductor and  are trademarks of Semiconductor Components Industries, LLC dba ON Semiconductor or its subsidiaries in the United States and/or other countries. ON Semiconductor reserves the right to make changes without further notice to any products herein. ON Semiconductor makes no warranty, representation or guarantee regarding the suitability of its products for any particular purpose, nor does ON Semiconductor assume any liability arising out of the application or use of any product or circuit, and specifically disclaims any and all liability, including without limitation special, consequential or incidental damages. ON Semiconductor does not convey any license under its patent rights nor the rights of others.

ON Semiconductor and  are trademarks of Semiconductor Components Industries, LLC dba ON Semiconductor or its subsidiaries in the United States and/or other countries. ON Semiconductor owns the rights to a number of patents, trademarks, copyrights, trade secrets, and other intellectual property. A listing of ON Semiconductor's product/patent coverage may be accessed at www.onsemi.com/site/pdf/Patent-Marking.pdf. ON Semiconductor reserves the right to make changes without further notice to any products herein. ON Semiconductor makes no warranty, representation or guarantee regarding the suitability of its products for any particular purpose, nor does ON Semiconductor assume any liability arising out of the application or use of any product or circuit, and specifically disclaims any and all liability, including without limitation special, consequential or incidental damages. Buyer is responsible for its products and applications using ON Semiconductor products, including compliance with all laws, regulations and safety requirements or standards, regardless of any support or applications information provided by ON Semiconductor. "Typical" parameters which may be provided in ON Semiconductor data sheets and/or specifications can and do vary in different applications and actual performance may vary over time. All operating parameters, including "Typicals" must be validated for each customer application by customer's technical experts. ON Semiconductor does not convey any license under its patent rights nor the rights of others. ON Semiconductor products are not designed, intended, or authorized for use as a critical component in life support systems or any FDA Class 3 medical devices or medical devices with a same or similar classification in a foreign jurisdiction or any devices intended for implantation in the human body. Should Buyer purchase or use ON Semiconductor products for any such unintended or unauthorized application, Buyer shall indemnify and hold ON Semiconductor and its officers, employees, subsidiaries, affiliates, and distributors harmless against all claims, costs, damages, and expenses, and reasonable attorney fees arising out of, directly or indirectly, any claim of personal injury or death associated with such unintended or unauthorized use, even if such claim alleges that ON Semiconductor was negligent regarding the design or manufacture of the part. ON Semiconductor is an Equal Opportunity/Affirmative Action Employer. This literature is subject to all applicable copyright laws and is not for resale in any manner.

PUBLICATION ORDERING INFORMATION

LITERATURE FULFILLMENT:

Email Requests to: orderlit@onsemi.com

ON Semiconductor Website: www.onsemi.com

TECHNICAL SUPPORT

North American Technical Support:
Voice Mail: 1 800-282-9855 Toll Free USA/Canada
Phone: 011 421 33 790 2910

Europe, Middle East and Africa Technical Support:

Phone: 00421 33 790 2910

For additional information, please contact your local Sales Representative

Mouser Electronics

Authorized Distributor

Click to View Pricing, Inventory, Delivery & Lifecycle Information:

[onsemi:](#)

[NB3N511DG](#) [NB3N511DR2G](#)