

Clocks

July 2023

LMK04828

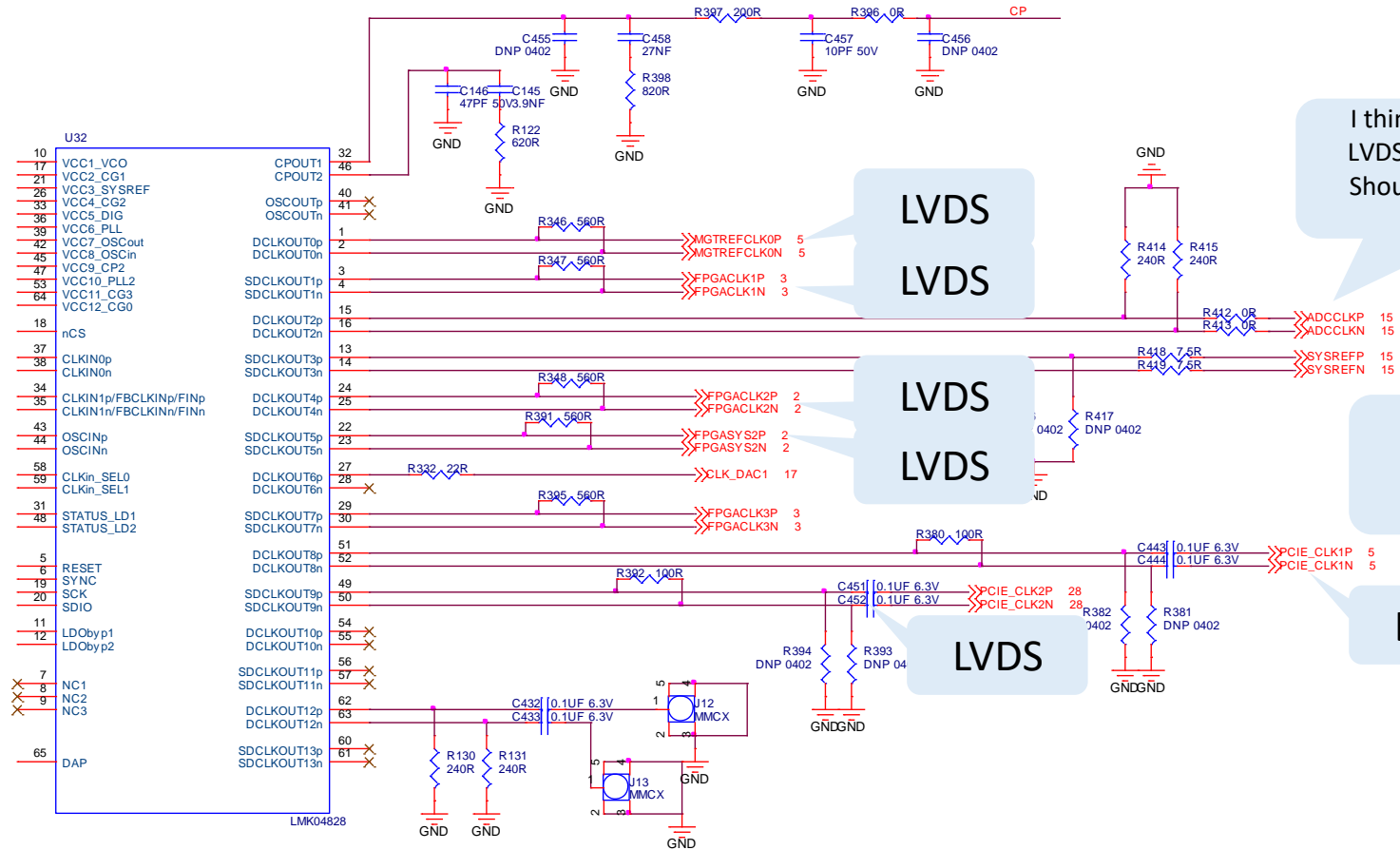

I think I need to change to LVDS (see Slide 5 for ADC). Should I remove R414 and R415?

I think I need to change to LVDS (see Slide 5 for ADC). Should I replace R418 and R419 with 0 Ohm?

LVDS

XC7K70T-1FBG484I (Xilinx FPGA)

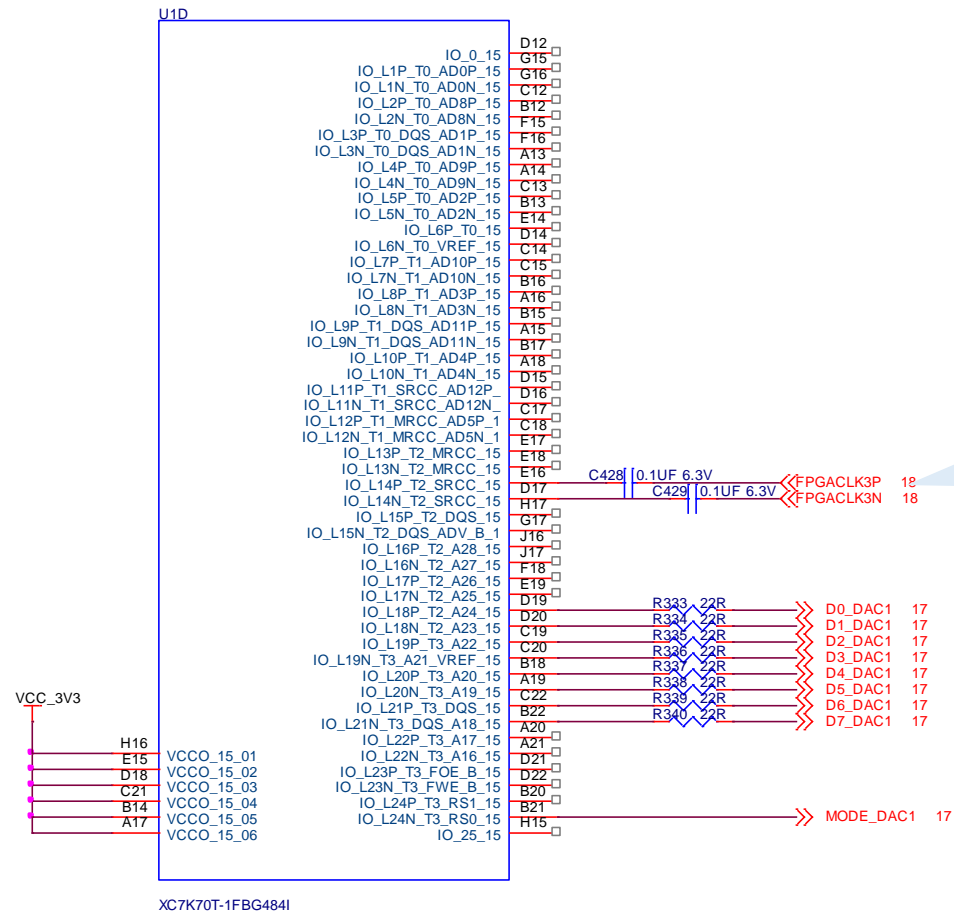

LVDS

XC7K70T-1FBG484I (Xilinx FPGA)

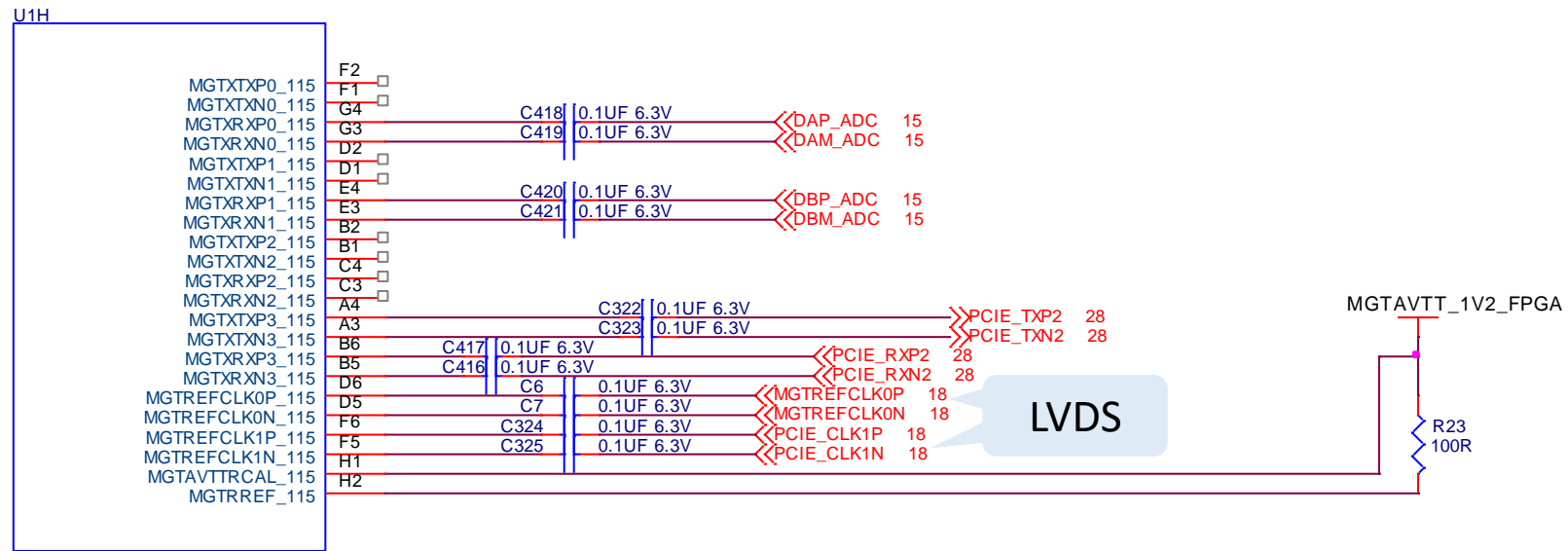

XC7K70T-1FBG484I

ADC32J25IRGZT

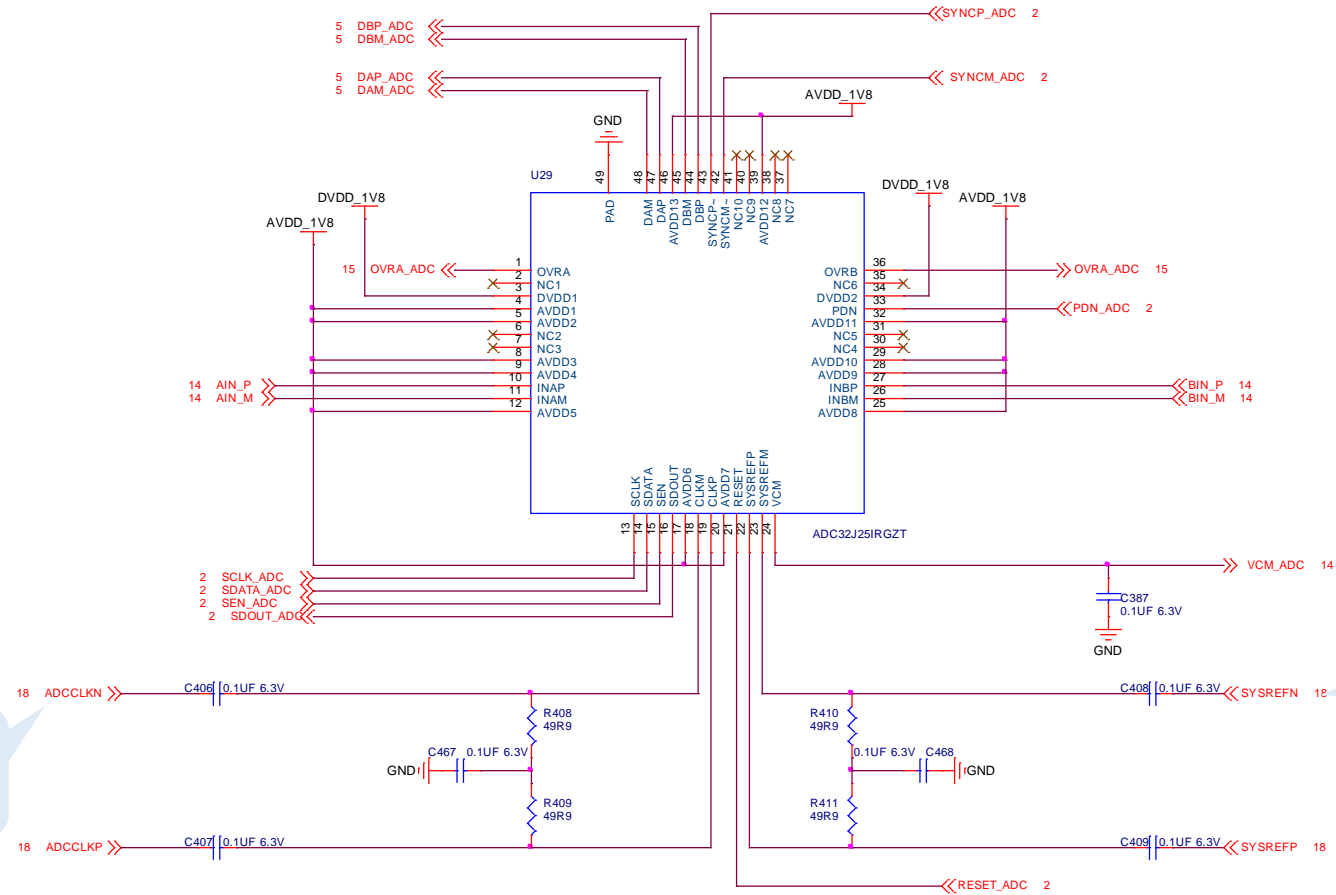

Does this assume LVDS?

Does this assume LVDS?