



Nemko Test Report: 10238472RUS1

Applicant: Texas Instruments, Inc
12500 TI Blvd
Dallas, TX 75243
USA

**Equipment Under Test:
(E.U.T.)** CC256x QFN EM

FCC ID#: Z64-CC256xEM
IC ID# 4511-CC256xEM

In Accordance With: **FCC Part 15, Subpart C, 15.247 and
Industry Canada RSS-210, Issue 8**

Tested By: Nemko USA Inc.
802 N. Kealy
Lewisville, Texas 75057-3136

TESTED BY: 

David Light, Senior Wireless Engineer **DATE:** 04 April 2013

APPROVED BY: 

Michael Cantwell **DATE:** 5-Apr-2013

Total Number of Pages: 83

Table of Contents

SECTION 1.	SUMMARY OF TEST RESULTS	3
SECTION 2.	EQUIPMENT UNDER TEST (E.U.T.)	5
SECTION 3.	CHANNEL SEPARATION	7
SECTION 4.	TIME OF OCCUPANCY	18
SECTION 5.	PEAK POWER OUTPUT	22
SECTION 6.	SPURIOUS EMISSIONS (ANTENNA CONDUCTED)	36
SECTION 7.	SPURIOUS EMISSIONS (RADIATED)	53
SECTION 8.	POWERLINE CONDUCTED EMISSIONS	62
SECTION 9.	PEAK POWER SPECTRAL DENSITY	64
SECTION 10.	OCCUPIED BANDWIDTH	68
SECTION 11.	TEST EQUIPMENT LIST	73
ANNEX A - TEST DETAILS		74
ANNEX B - TEST DIAGRAMS		83

EQUIPMENT: CC256x QFN EM

PROJECT NO.:10238472RUS1

Section 1. Summary of Test Results

Manufacturer: Texas Instruments, Inc.

Model No.: CC256x QFN EM

Serial No.: 2825200002 (Radiated) and 2825200002 (Conducted)

General: **All measurements are traceable to national standards.**

These tests were conducted on a sample of the equipment for the purpose of demonstrating compliance with Part 15, Subpart C, Paragraph 15.247 and Industry Canada RSS-210, Issue 8 for operation in the band 2400 to 2483.5 MHz. Radiated tests were conducted in accordance with ANSI C63.4-2003. Radiated emissions are made on an open area test site. A description of the test facility is on file with the FCC and Industry Canada.

- | | | | |
|-------------------------------------|----------------------------|-------------------------------------|---------------------|
| <input checked="" type="checkbox"/> | New Submission | <input checked="" type="checkbox"/> | Production Unit |
| <input type="checkbox"/> | Class II Permissive Change | <input type="checkbox"/> | Pre-Production Unit |

THIS TEST REPORT RELATES ONLY TO THE ITEM(S) TESTED.

THE FOLLOWING DEVIATIONS FROM, ADDITIONS TO, OR EXCLUSIONS FROM THE TEST SPECIFICATIONS HAVE BEEN MADE.

See " Summary of Test Data".



This report must not be used to claim product certification, approval, or endorsement by NVLAP, NIST, or any agency of the Federal Government. Nemko USA, Inc. is a NVLAP accredited laboratory.

Nemko USA Inc. authorizes the above named company to reproduce this report provided it is reproduced in its entirety and for use by the company's employees only.

Any use which a third party makes of this report, or any reliance on or decisions to be made based on it, are the responsibility of such third parties. Nemko USA Inc. accepts no responsibility for damages, if any, suffered by any third party as a result of decisions made or actions based on this report. This report applies only to the items tested.

Summary Of Test Data

NAME OF TEST	PARA. NO.	RESULT
Powerline Conducted Emissions	15.207(a) / RSS-Gen 7.2.4	Complies
Channel Separation	15.247(a)(1) / RSS-210 A8.1(b)	Complies
Time of Occupancy	15.247(a)(1) / RSS-210 A8.1(d)	Complies
20 dB Occupied Bandwidth	15.247(a)(1) / RSS-210 A8.1(a)	Complies
Peak Power Output	15.247(b) / RSS-210 A8.4	Complies
Spurious Emissions(Antenna Conducted)	15.247(d) / RSS-210 A8.5	Complies
Spurious Emissions (Radiated)	15.247(d) / RSS-Gen 7.2.2	Complies
6 dB Occupied Bandwidth	15.247(a)(2) / RSS-210 A8.2	Complies
Peak Power Spectral Density	15.247(e) / RSS-210 A8.2(b)	Complies

Footnotes:

Section 2. Equipment Under Test (E.U.T.)

General Equipment Information

Frequency Band: 902 – 928 MHz
 2400 – 2483.5 MHz
 5725 – 5850 MHz

Operating Frequency Range: 2402 to 2480 MHz

Number of Channels: 79

Channel Spacing: 1 MHz

User Frequency Adjustment: Software controlled

Description of EUT

The CC256x QFN EM is a Bluetooth evaluation module.

System Diagram

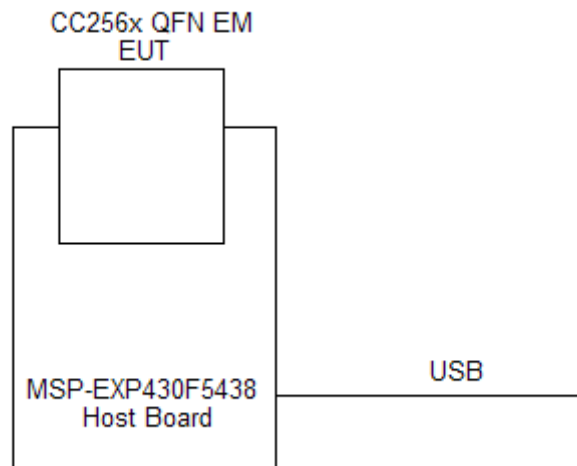

EQUIPMENT: CC256x QFN EM

PROJECT NO.:10238472RUS1

Section 3. Channel Separation

NAME OF TEST: Channel Separation	PARA. NO.: 15.247(a)(1) A8.1(b)
TESTED BY: David Light	DATE: 29 January 2013

Test Results: Complies.

Measurement Data: See 20 dB BW plot
Measured 20 dB bandwidth: 1.383 MHz Max
Channel Separation: 1 MHz

Equipment Used: 1036-1082-1472

Measurement Uncertainty: 1×10^{-7} ppm

Temperature: 22 °C

Relative Humidity: 60 %

Test Data – Channel Separation

 Ref Lvl 20 dBm
Delta 1 [T1] -0.02 dB
-1.00000000 MHz
RBW 100 kHz
VBW 100 kHz
SWT 5 ms
RF Att 20 dB
Unit dBm

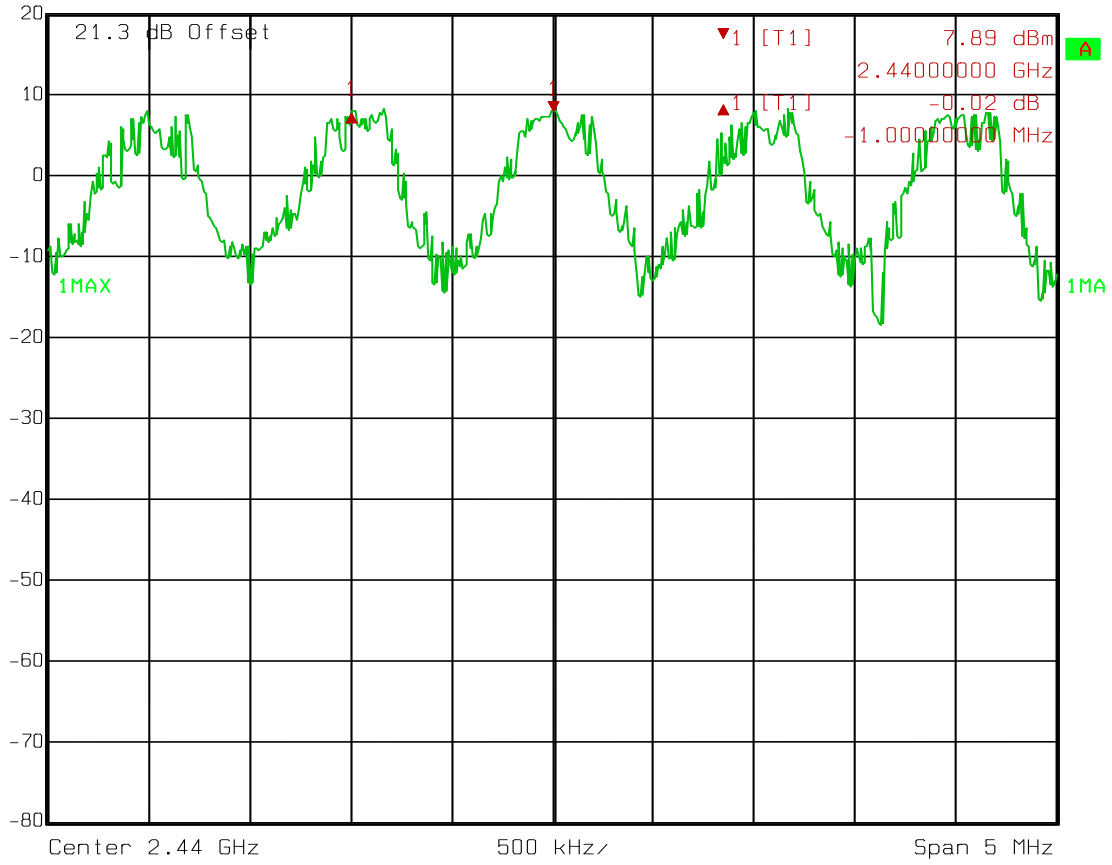

Date: 29.JAN.2013 11:29:57

Test Data – 20 dB Bandwidth

Occupied Bandwidth

Low Channel

GFSK



Ref Lvl	Delta 1 [T1]	RBW	10 kHz	RF Att	20 dB
20 dBm	-2.55 dB	VBW	10 kHz		
	931.86372745 kHz	SWT	125 ms	Unit	dBm

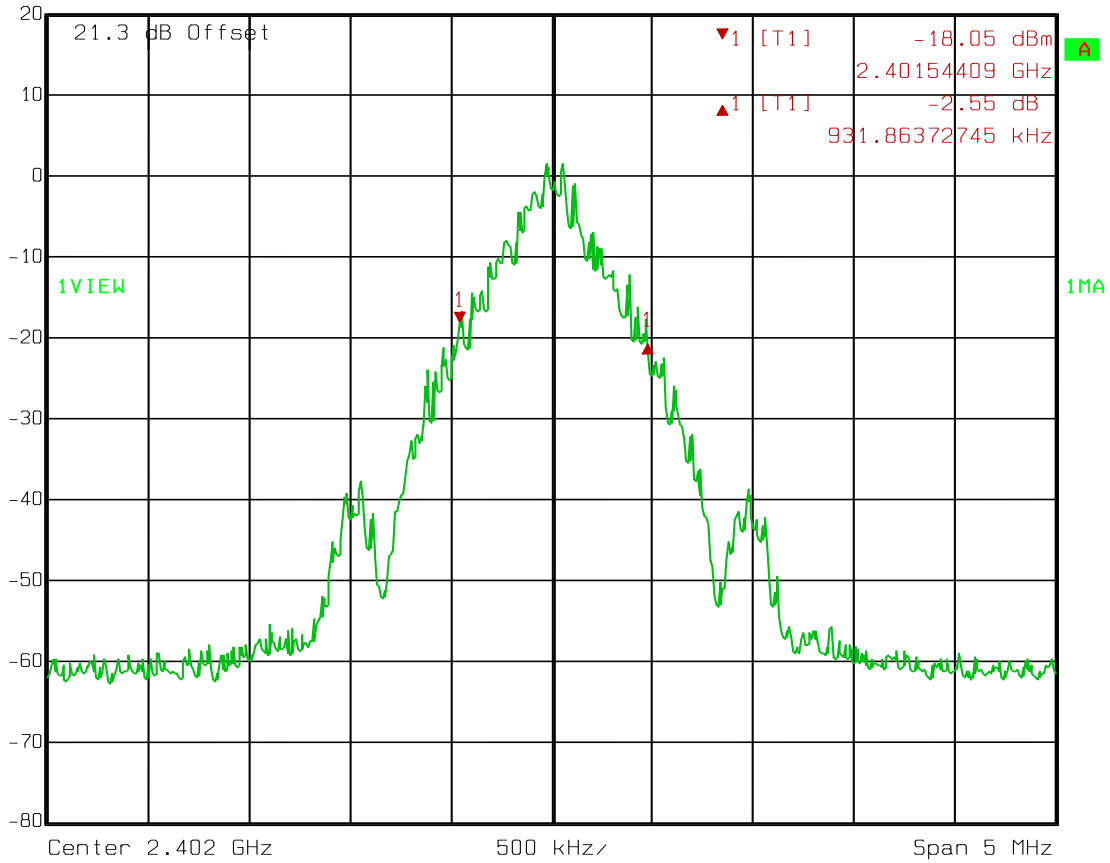

Date: 29.JAN.2013 11:03:51

Test Data – 20 dB Bandwidth

Occupied Bandwidth
Mid Channel
GFSK



Ref Lvl	Delta 1 [T1]	RBW	10 kHz	RF Att	20 dB
20 dBm	0.99 dB	VBW	10 kHz		
	921.84368738 kHz	SWT	125 ms	Unit	dBm

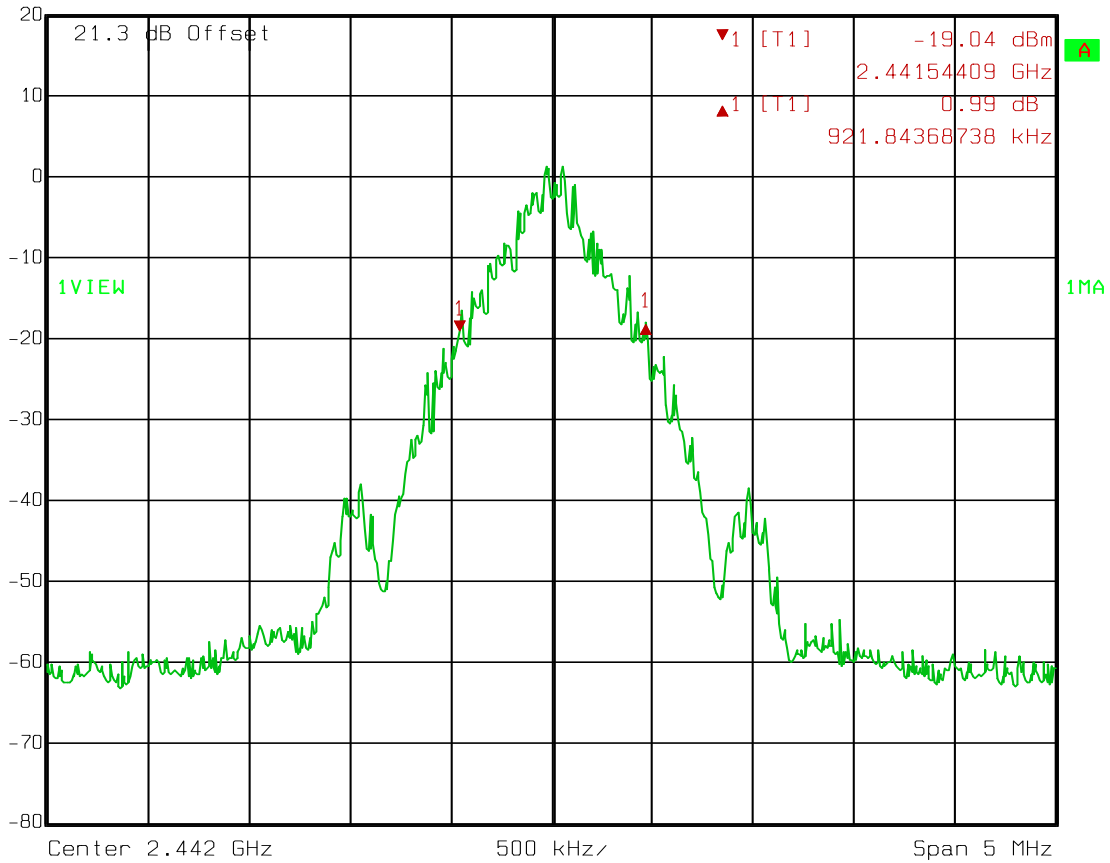

Date: 29.JAN.2013 11:02:31

Test Data – 20 dB Bandwidth

Occupied Bandwidth
High Channel
GFSK

	Delta 1 [T1]	RBW	10 kHz	RF Att	20 dB
	Ref Lvl	2.24 dB	VBW	10 kHz	
	20 dBm	931.86372745 kHz	SWT	125 ms	Unit dBm

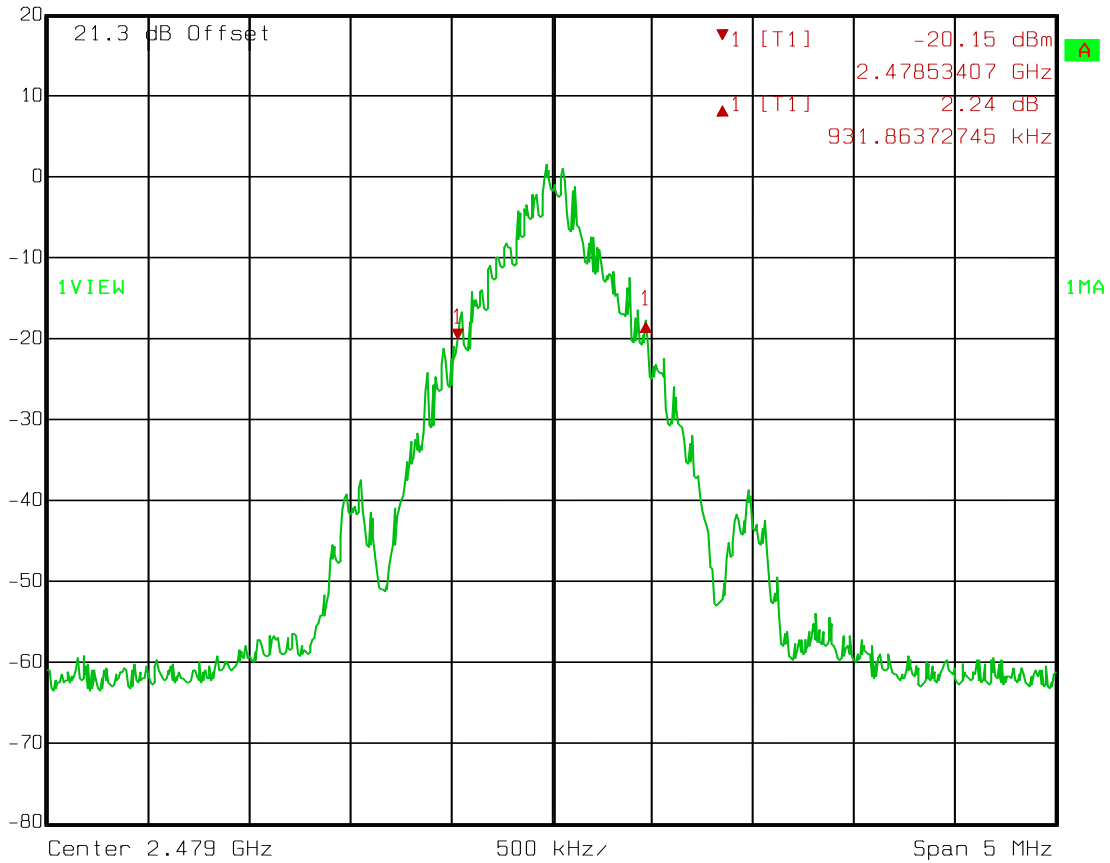

Date: 29.JAN.2013 11:04:47

Test Data – 20 dB Bandwidth

Occupied Bandwidth
Low Channel
EDR2

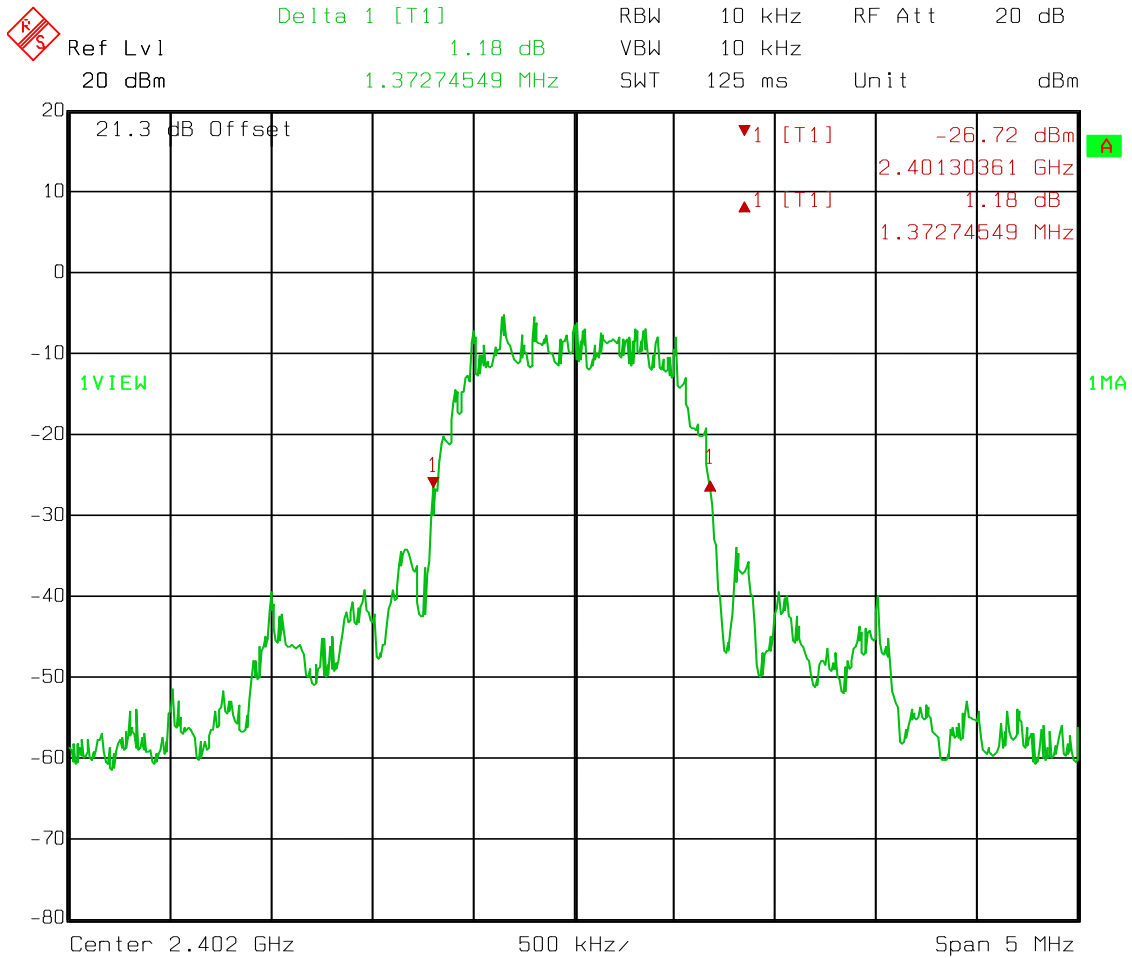

Date: 29.JAN.2013 11:08:06

Test Data – 20 dB Bandwidth

Occupied Bandwidth
Mid Channel
EDR2

	Delta 1 [T1]	RBW	10 kHz	RF Att	20 dB
	Ref Lvl	0.50 dB	VBW	10 kHz	
	20 dBm	1.37274549 MHz	SWT	125 ms	Unit dBm

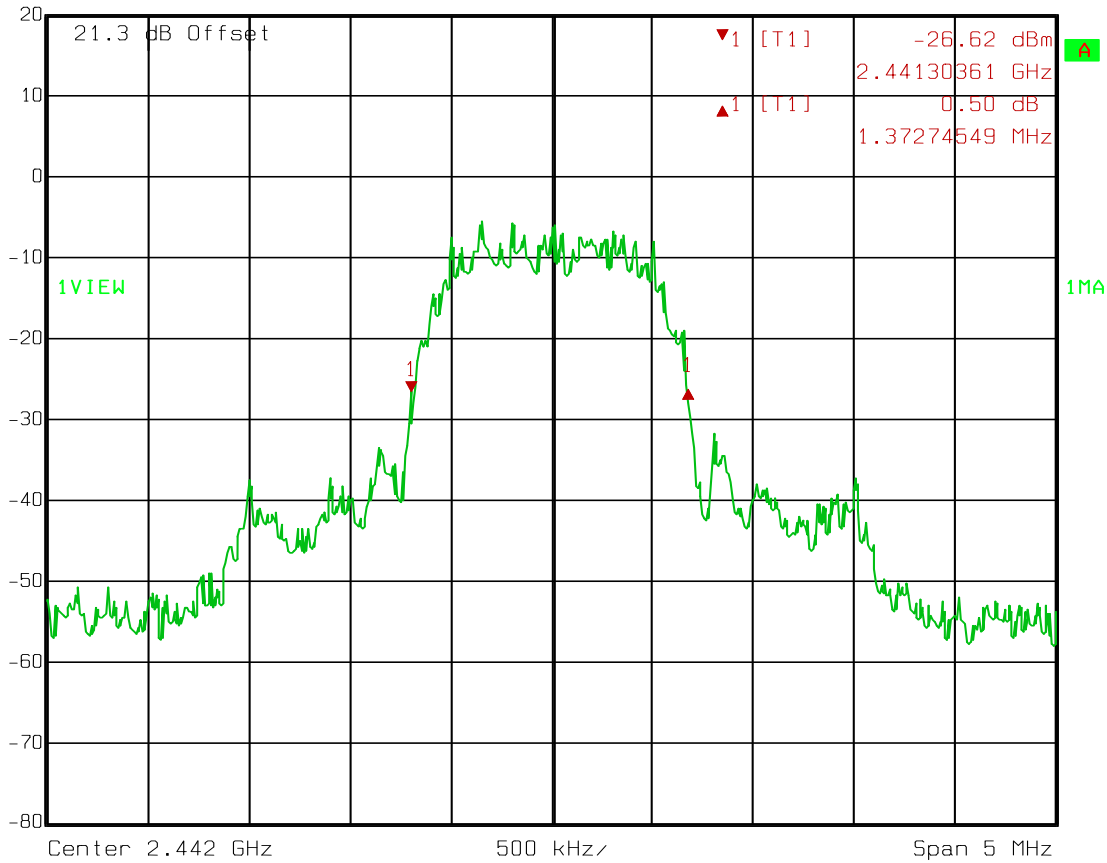

Date: 29.JAN.2013 11:06:55

Test Data – 20 dB Bandwidth

Occupied Bandwidth
High Channel
EDR2

ES	Delta 1 [T1]	RBW	10 kHz	RF Att	20 dB
	Ref Lvl	-1.36 dB	VBW	10 kHz	
	20 dBm	1.36272545 MHz	SWT	125 ms	Unit dBm

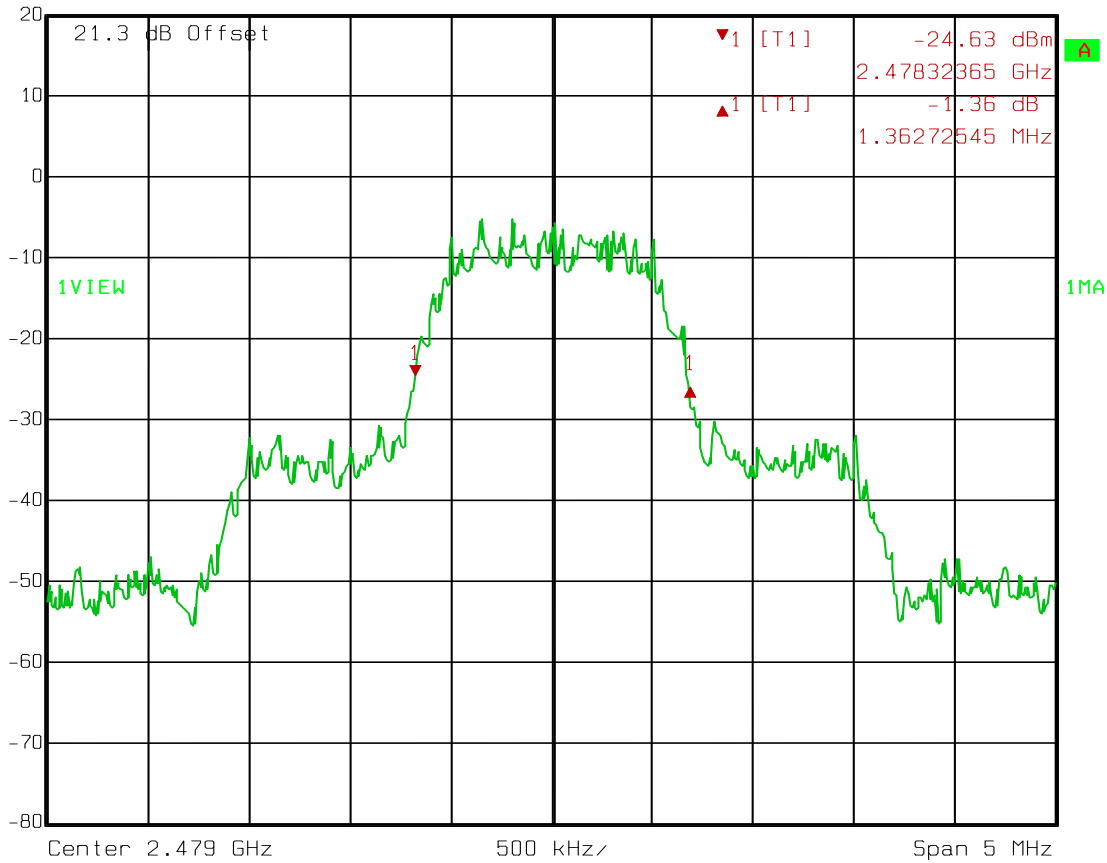

Date: 29.JAN.2013 11:06:01

Test Data – 20 dB Bandwidth

Occupied Bandwidth
Low Channel
EDR3

ES	Delta 1 [T1]	RBW	10 kHz	RF Att	20 dB
	Ref Lvl	0.38 dB	VBW	10 kHz	
	20 dBm	1.37274549 MHz	SWT	125 ms	Unit dBm

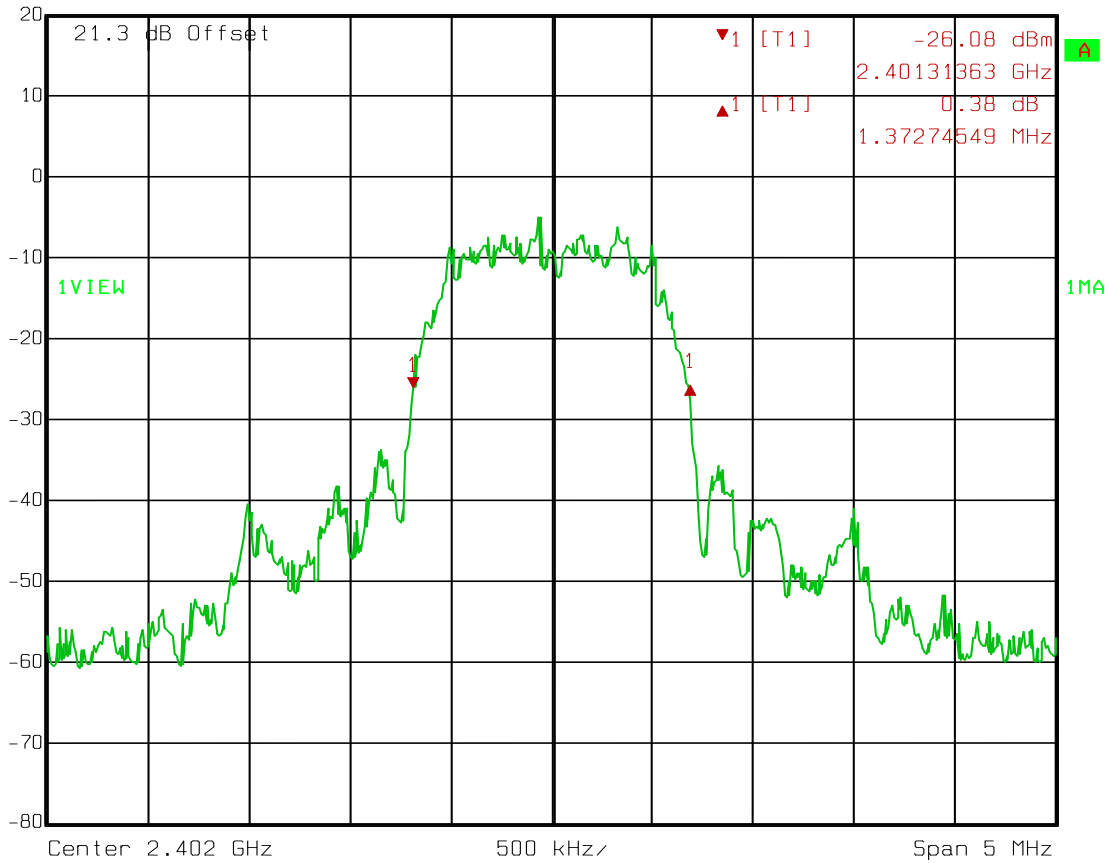

Date: 29.JAN.2013 11:09:17

Test Data – 20 dB Bandwidth

Occupied Bandwidth
Mid Channel
EDR3

	Delta 1 [T1]	RBW	10 kHz	RF Att	20 dB
	Ref Lvl	-0.78 dB	VBW	10 kHz	
	20 dBm	1.36272545 MHz	SWT	125 ms	Unit dBm

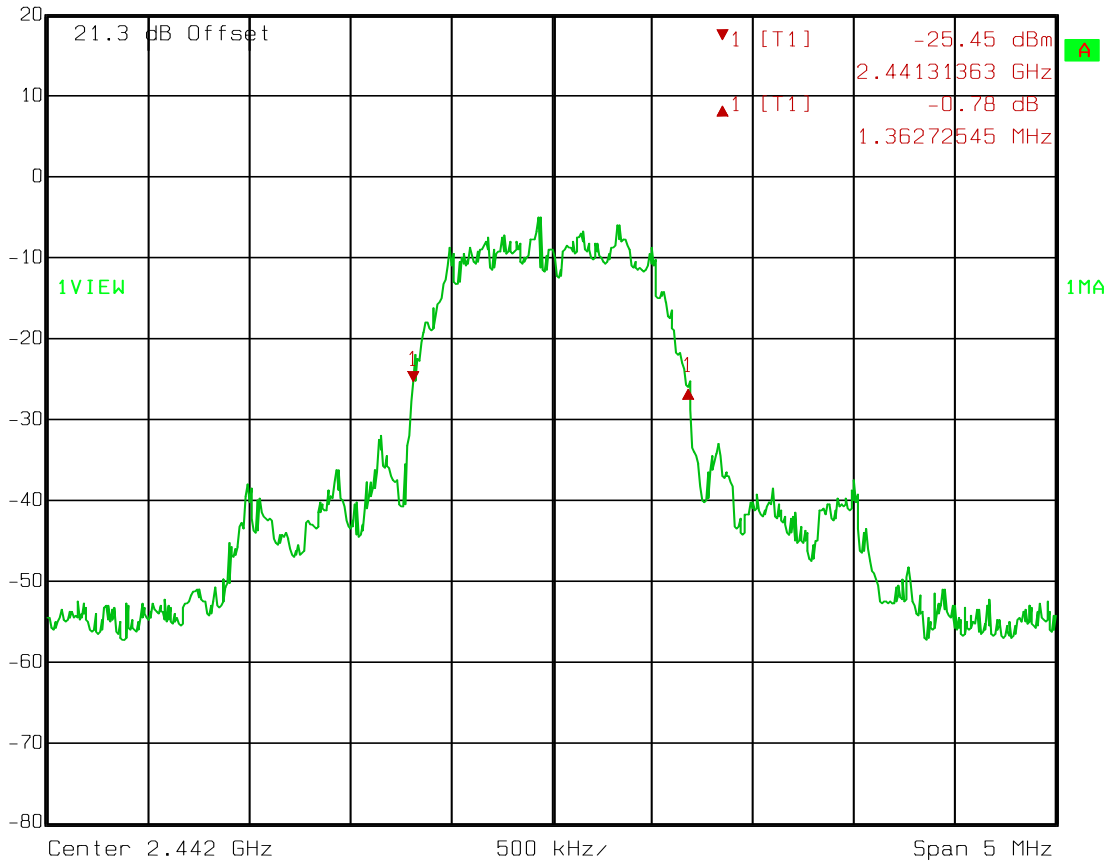

Date: 29.JAN.2013 11:10:05

Test Data – 20 dB Bandwidth

Occupied Bandwidth
High Channel
EDR3

	Delta 1 [T1]	RBW	10 kHz	RF Att	20 dB
	Ref Lvl	2.93 dB	VBW	10 kHz	
	20 dBm	1.38276553 MHz	SWT	125 ms	Unit dBm

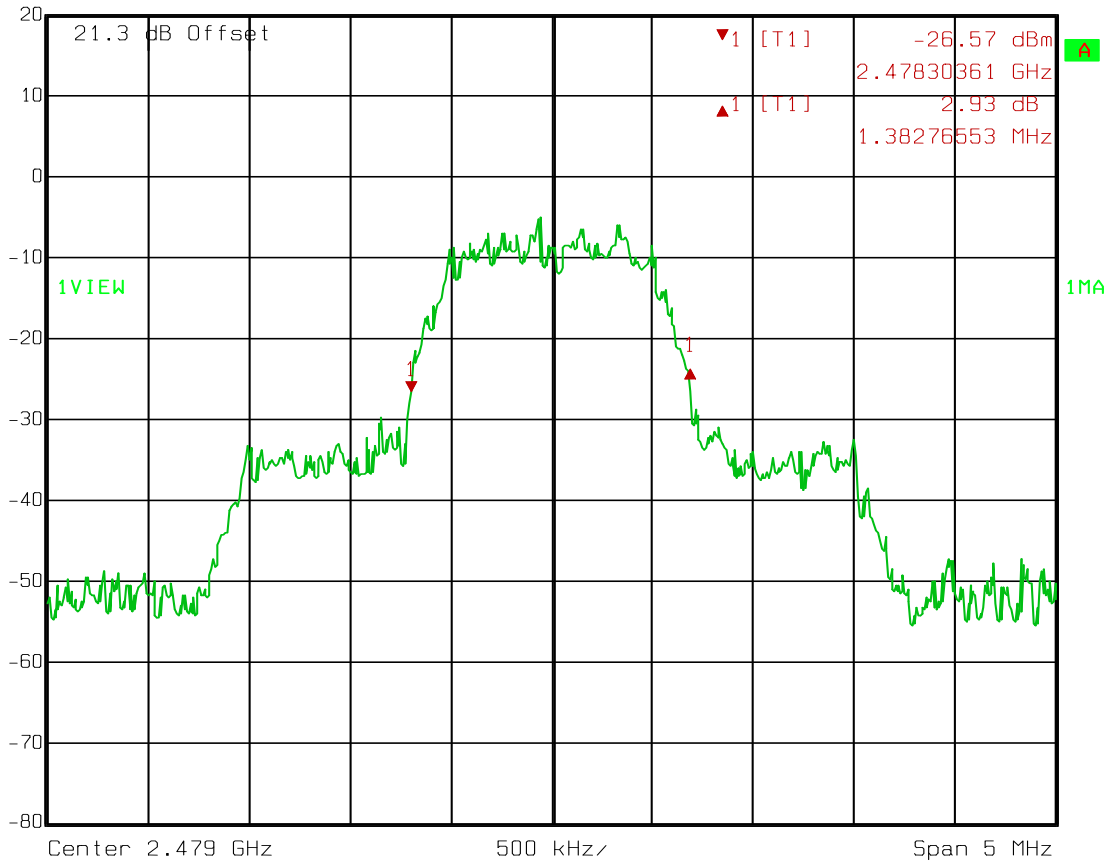

Date: 29.JAN.2013 11:10:57

EQUIPMENT: CC256x QFN EM

PROJECT NO.:10238472RUS1

Section 4. Time of Occupancy

NAME OF TEST: Time of Occupancy	PARA. NO.: 15.247(a)(1) A8.1(d)
TESTED BY: David Light	DATE: 29 January 2013

Test Results: Complies.

Measurement Data:

Maximum Dwell Time On Any Channel: 32 ms per 31.6 seconds

Equipment Used: 1036-1082-1472

Measurement Uncertainty: 1X10⁻⁷ppm

Temperature: 22 °C

Relative Humidity: 60 %

Test Data – Time of Occupancy

Pulse Width

	Delta 1 [T1]	RBW	100 kHz	RF Att	20 dB
	Ref Lvl	-16.00 dB	VBW	100 kHz	
	20 dBm	324.649299 μ s	SWT	1 ms	Unit

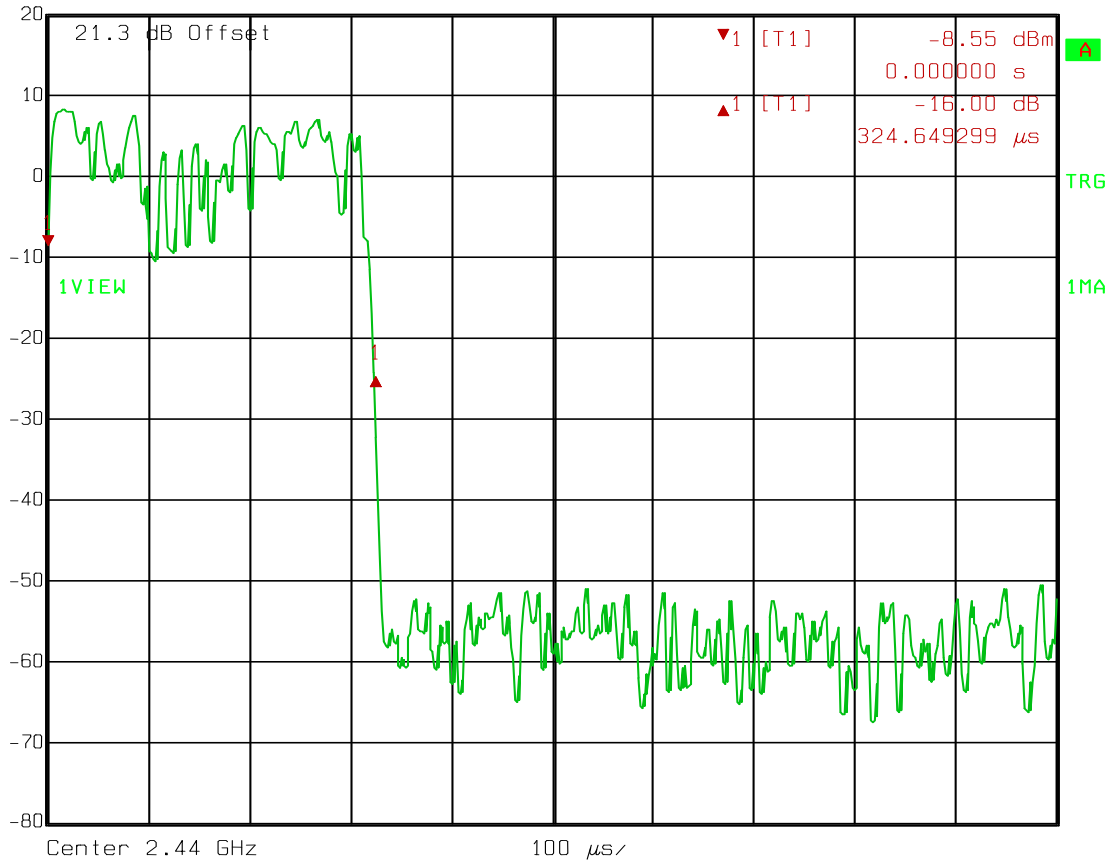

Date: 29.JAN.2013 11:34:01

Test Data – Time of Occupancy

Number of hops

0.4 seconds within a period of 0.4 seconds multiplied by the number of hopping channels employed

$$0.4 * 79 = 31.6 \text{ seconds}$$

$$0.000325 \text{ seconds} * 98 \text{ hops} = 0.032 \text{ seconds}$$

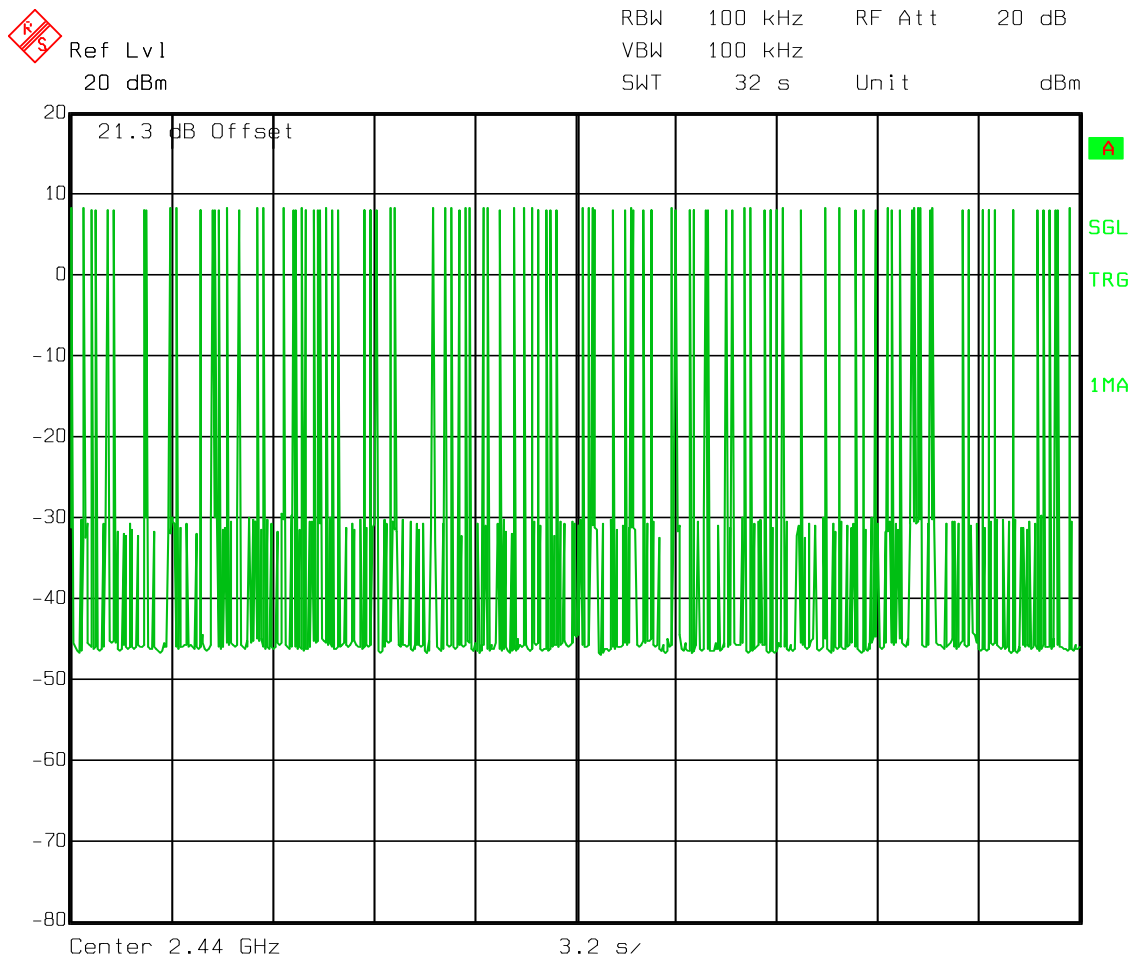

Test Data – Time of Occupancy

Number of hopping channels = 79

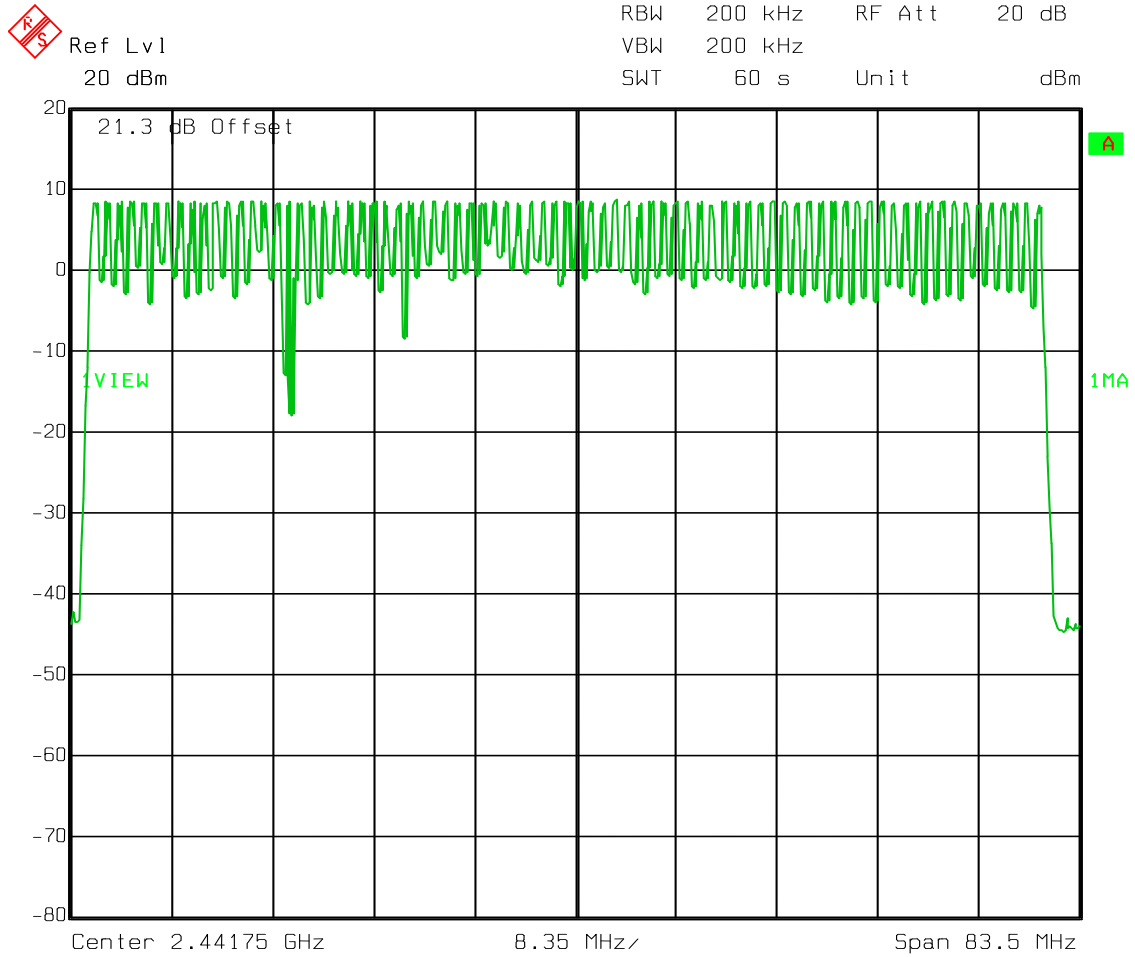

Date: 30.JAN.2013 13:16:05

Section 5. Peak Power Output

NAME OF TEST: Peak Power Output	PARA. NO.: 15.247 (b) A8.4
TESTED BY: David Light	DATE: 29 January 2013

Test Results: Complies.

Measurement Data: See attached plots.

Detachable antenna? Yes No
If yes, state the type of non-standard connector used:

Frequency (MHz)	Peak Power (dBm)	Peak Power (mW)	Antenna Type	Gain (dBi)	E.I.R.P. (dBm)	E.I.R.P. (mW)
2402 GFSK	8.3	6.8	Inverted F	3.3	11.6	14.5
2442 GFSK	8.2	6.6	Inverted F	3.3	11.5	14.1
2480 GFSK	8.1	6.5	Inverted F	3.3	11.4	13.8
2402 EDR2	8.1	6.5	Inverted F	3.3	11.4	13.8
2442 EDR2	8.1	6.5	Inverted F	3.3	11.4	13.8
2480 EDR2	8.1	6.5	Inverted F	3.3	11.4	13.8
2402 EDR3	8.8	7.6	Inverted F	3.3	12.1	16.2
2442 EDR3	8.8	7.6	Inverted F	3.3	12.1	16.2
2480 EDR3	8.5	7.1	Inverted F	3.3	11.8	15.1
2402 Bluetooth Low Energy	8.3	6.8	Inverted F	3.3	11.6	14.5
2442 Bluetooth Low Energy	8.4	6.9	Inverted F	3.3	11.7	14.8
2480 Bluetooth Low Energy	8.2	6.6	Inverted F	3.3	11.5	14.1
Maximum EIRP (mW): 16.2						

EQUIPMENT: CC256x QFN EM

PROJECT NO.:10238472RUS1

- This device was tested at +/- 15% input power per 15.31(e), with no variation in output power.
- For battery powered equipment, the device was tested with a fresh battery per 15.31(e).
- The device was tested on three channels per 15.31(l).
- This test was performed radiated.

Equipment Used: 1036-1082-1472

Measurement Uncertainty: 1.7 dB

Temperature: °C

Relative Humidity: %

Test Data

Power
Low Channel
GFSK

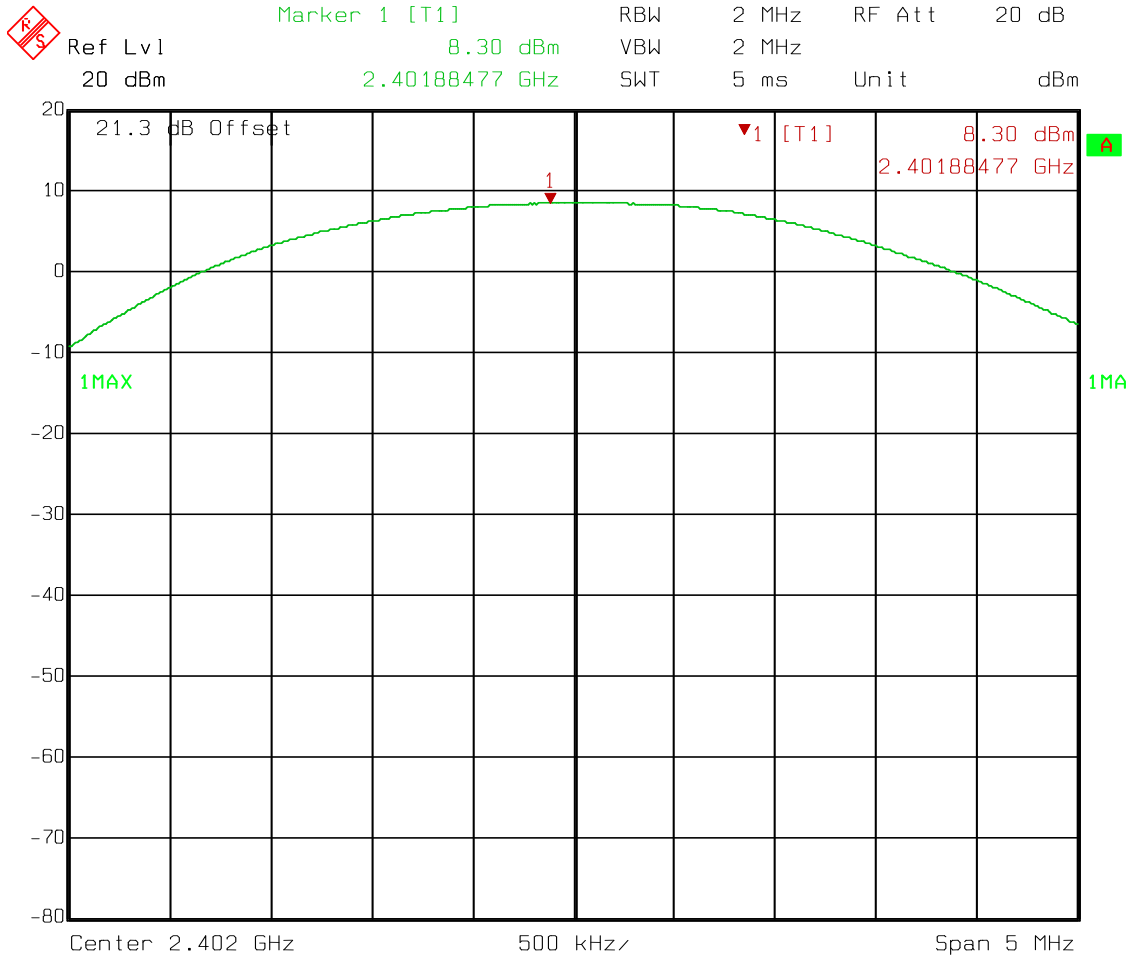

Date: 29.JAN.2013 10:34:48

Test Data

Power
Mid Channel
GFSK



Ref Lvl 20 dBm
Marker 1 [T1] 8.20 dBm 2.44216433 GHz
RBW 2 MHz RF Att 20 dB
VBW 2 MHz
SWT 5 ms Unit dBm

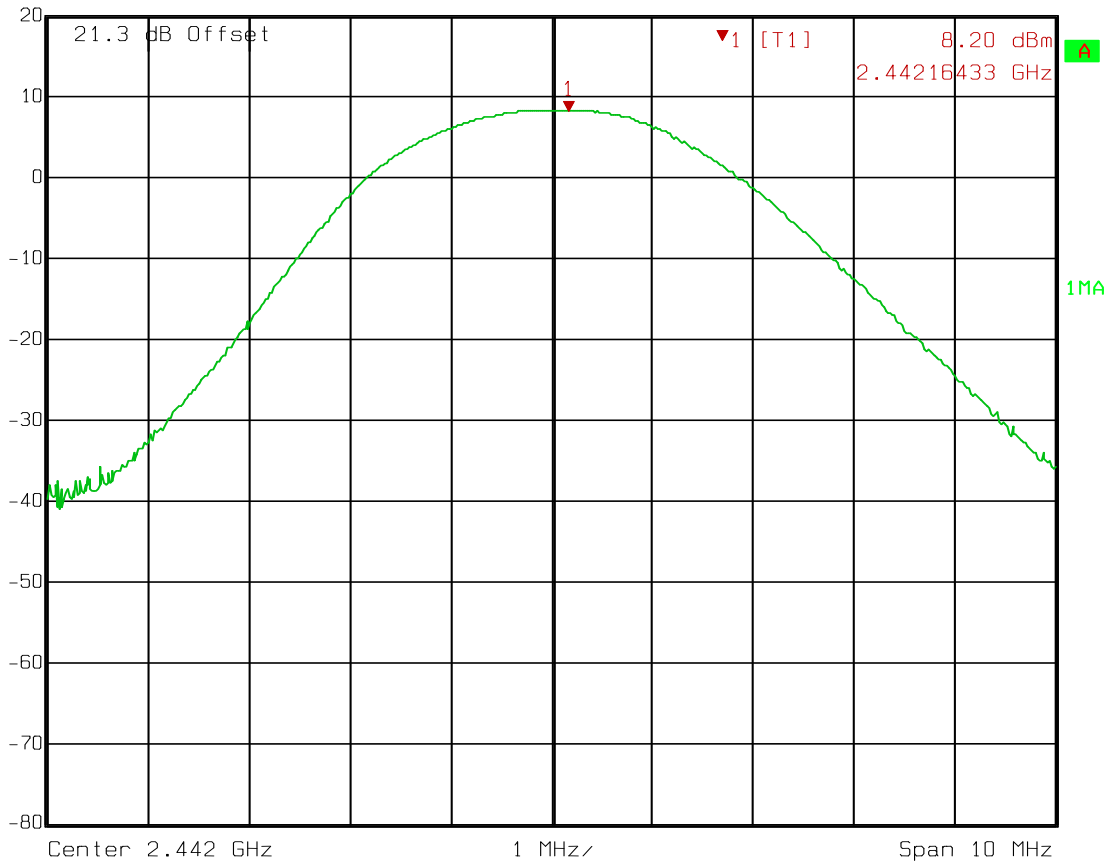

Date: 29.JAN.2013 10:44:16

Test Data

Power
Upper Channel
GFSK

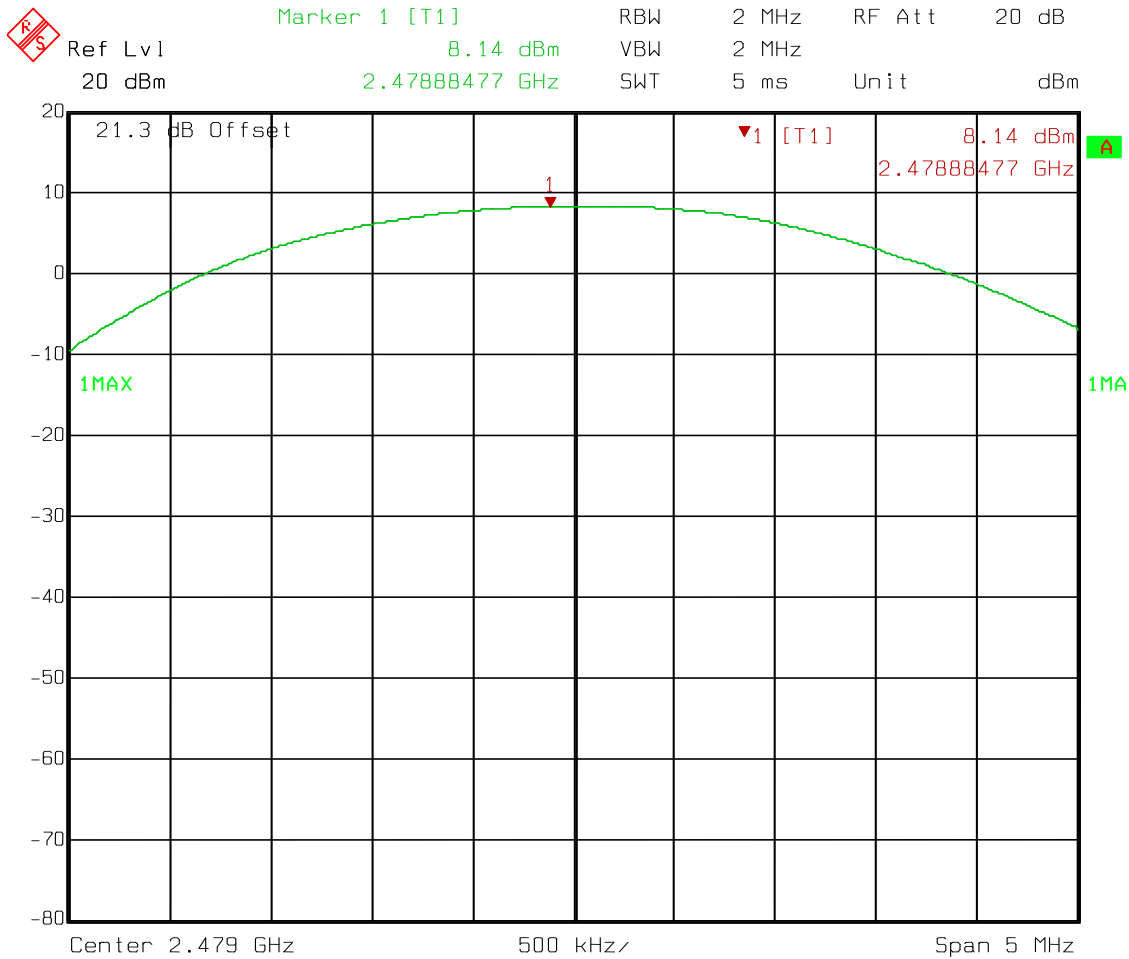

Date: 29.JAN.2013 10:40:07

Test Data

Power
Low Channel
EDR2



Marker 1 [T1] RBW 2 MHz RF Att 20 dB
8.09 dBm VBW 2 MHz
2.40192986 GHz SWT 5 ms Unit dBm

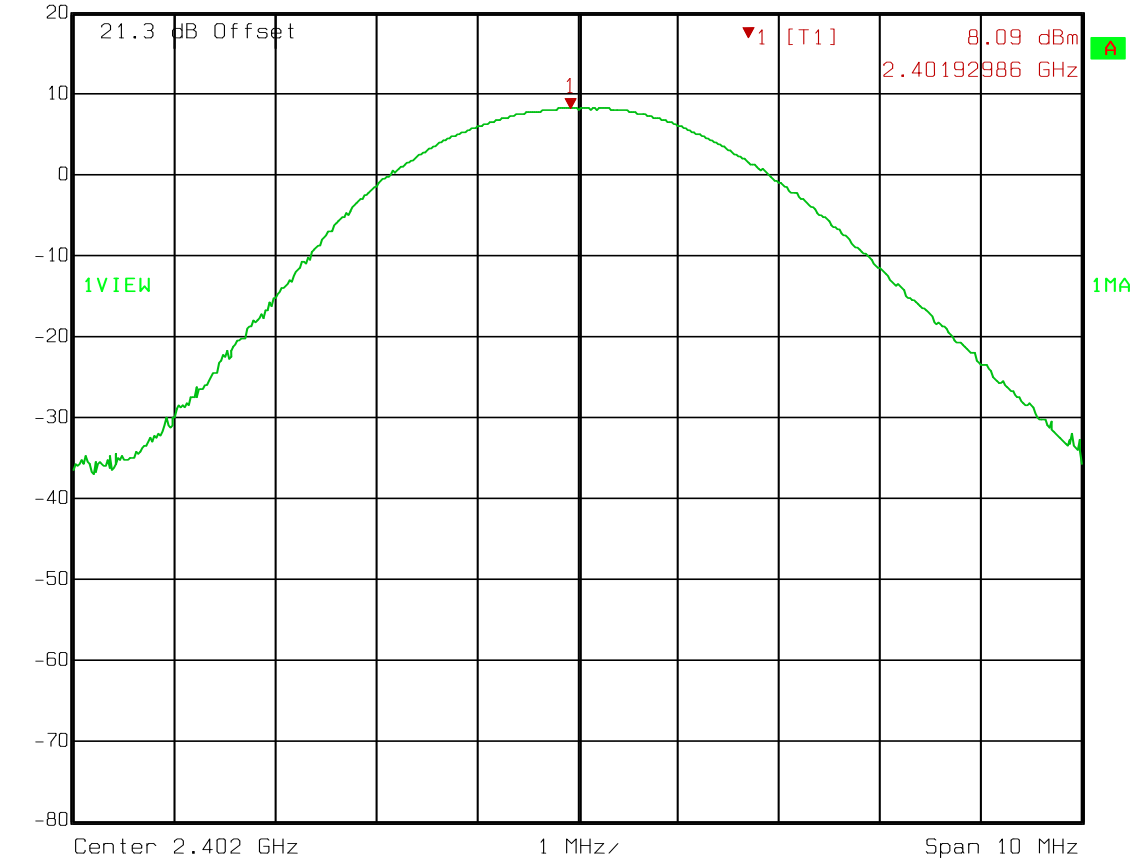

Date: 29.JAN.2013 10:48:31

Test Data

Power
Mid Channel
EDR2

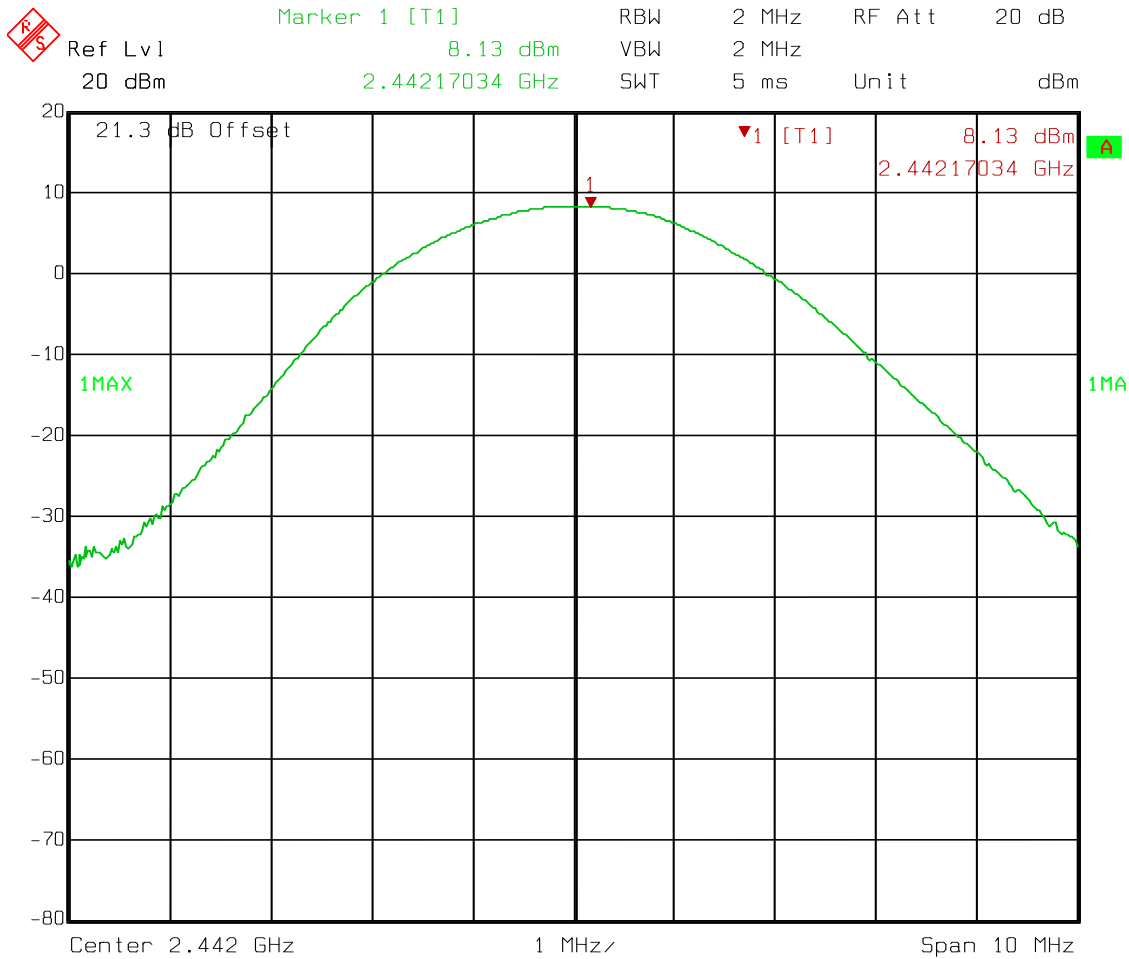

Date: 29.JAN.2013 10:49:12

Test Data

Power
Upper Channel
EDR2



Marker 1 [T1] RBW 2 MHz RF Att 20 dB
8.06 dBm VBW 2 MHz
2.47917034 GHz SWT 5 ms Unit dBm
Ref Lvl 20 dBm

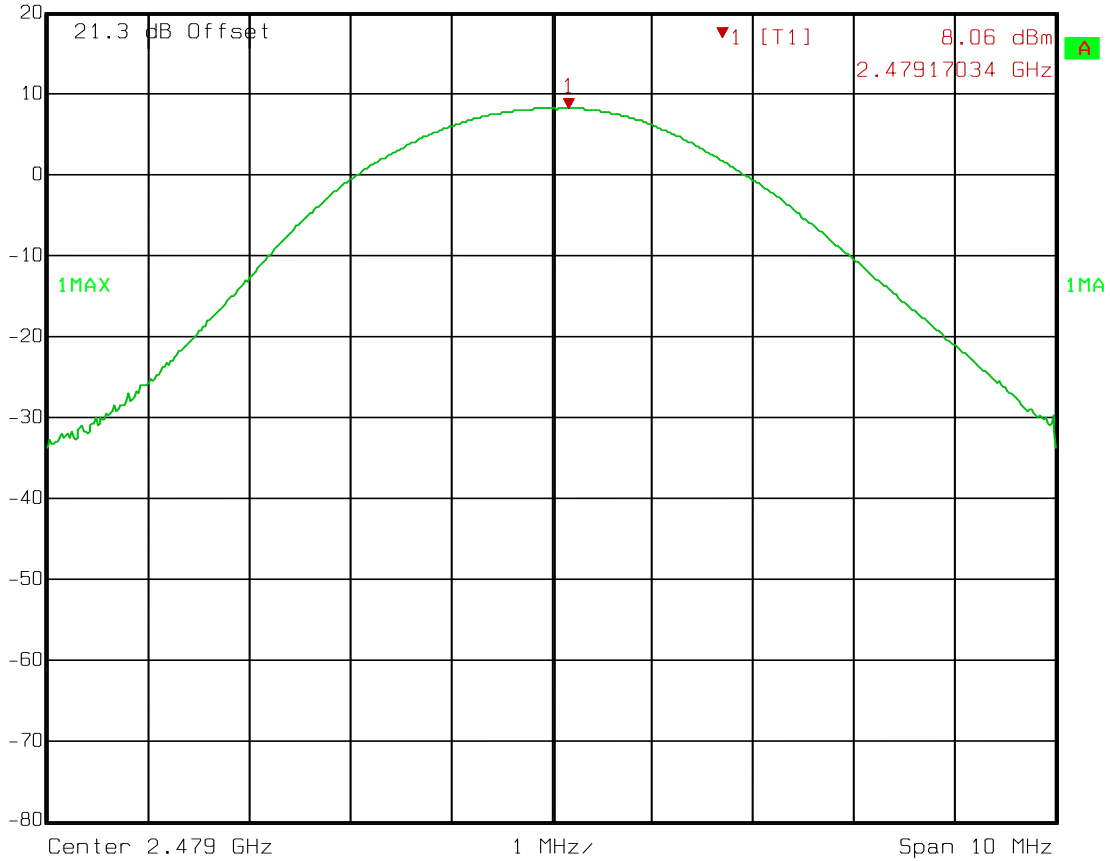

Date: 29.JAN.2013 10:50:02

Test Data

Power
Low Channel
EDR3



Marker 1 [T1] RBW 2 MHz RF Att 20 dB
8.78 dBm VBW 2 MHz
2.40205010 GHz SWT 5 ms Unit dBm
Ref Lvl 20 dBm

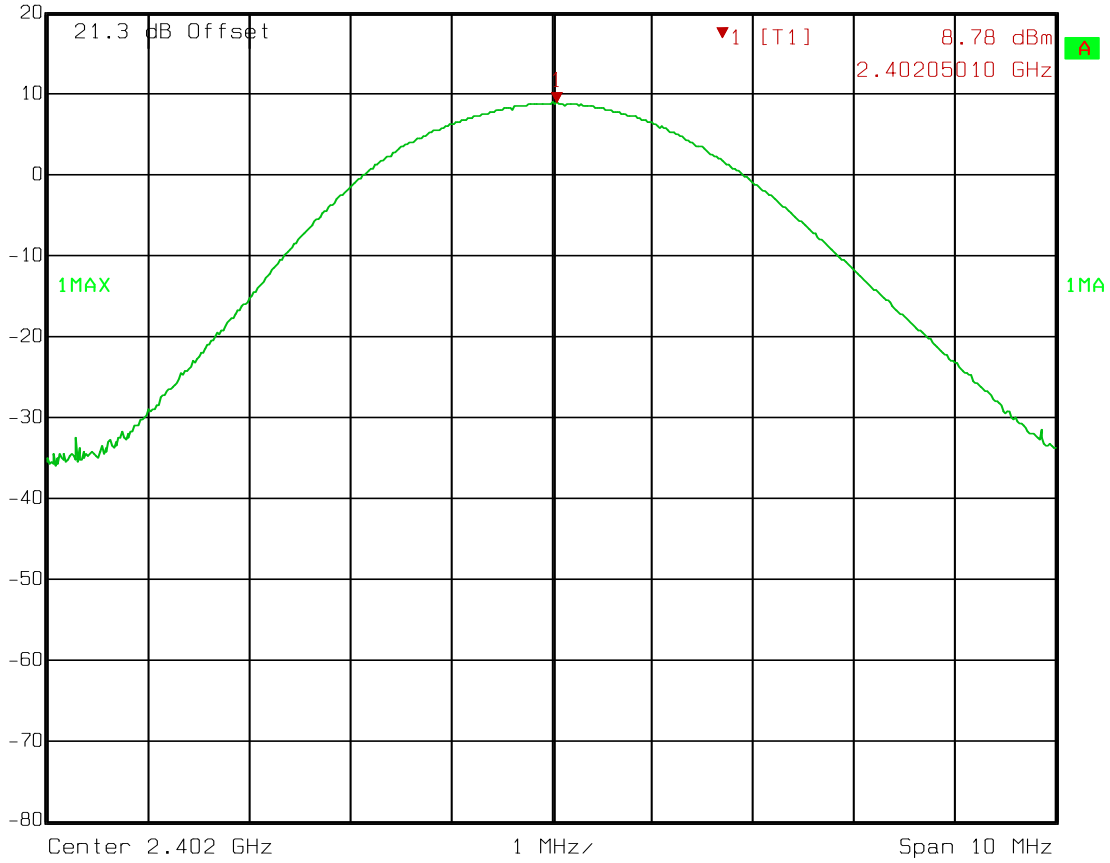

Date: 29.JAN.2013 10:50:43

Test Data

Power
Mid Channel
EDR3



Marker 1 [T1] RBW 2 MHz RF Att 20 dB
8.77 dBm VBW 2 MHz
2.44205010 GHz SWT 5 ms Unit dBm
Ref Lvl 20 dBm

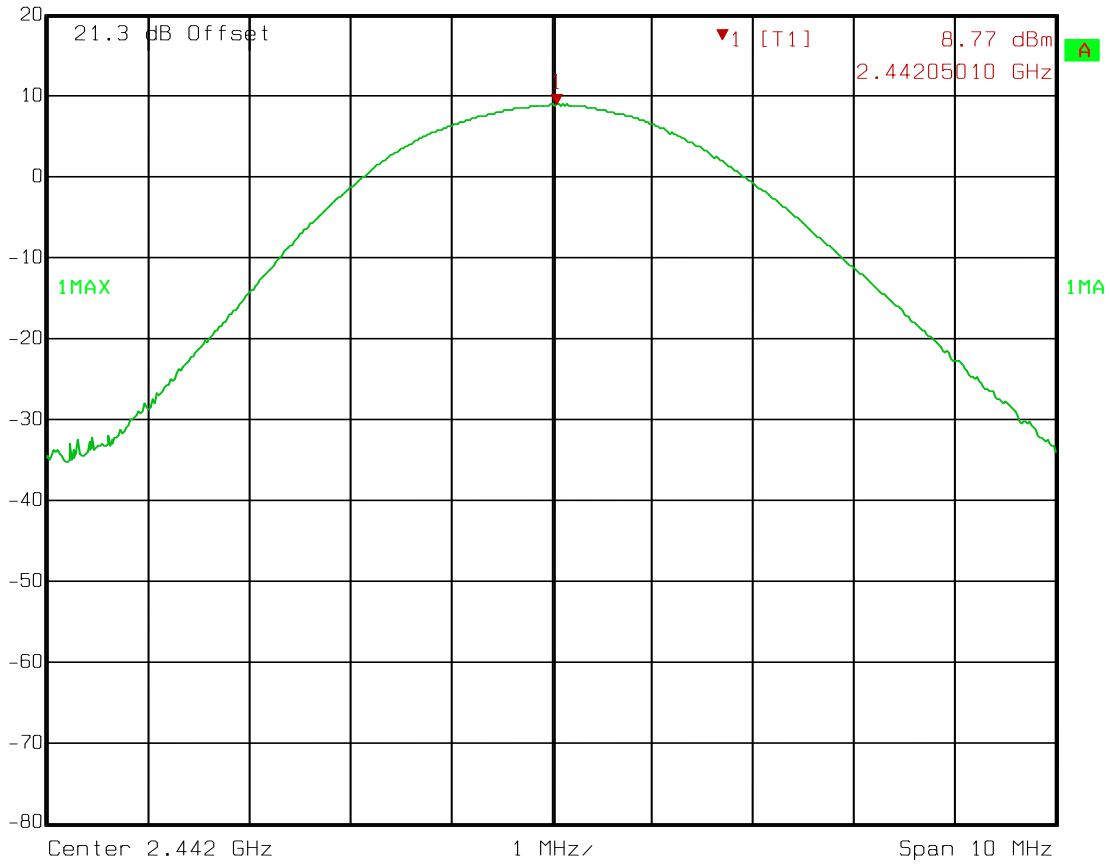

Date: 29.JAN.2013 10:51:18

Test Data

Power
Upper Channel
EDR3



Marker 1 [T1] RBW 2 MHz RF Att 20 dB
8.45 dBm VBW 2 MHz
2.47907014 GHz SWT 5 ms Unit dBm
Ref Lvl 20 dBm

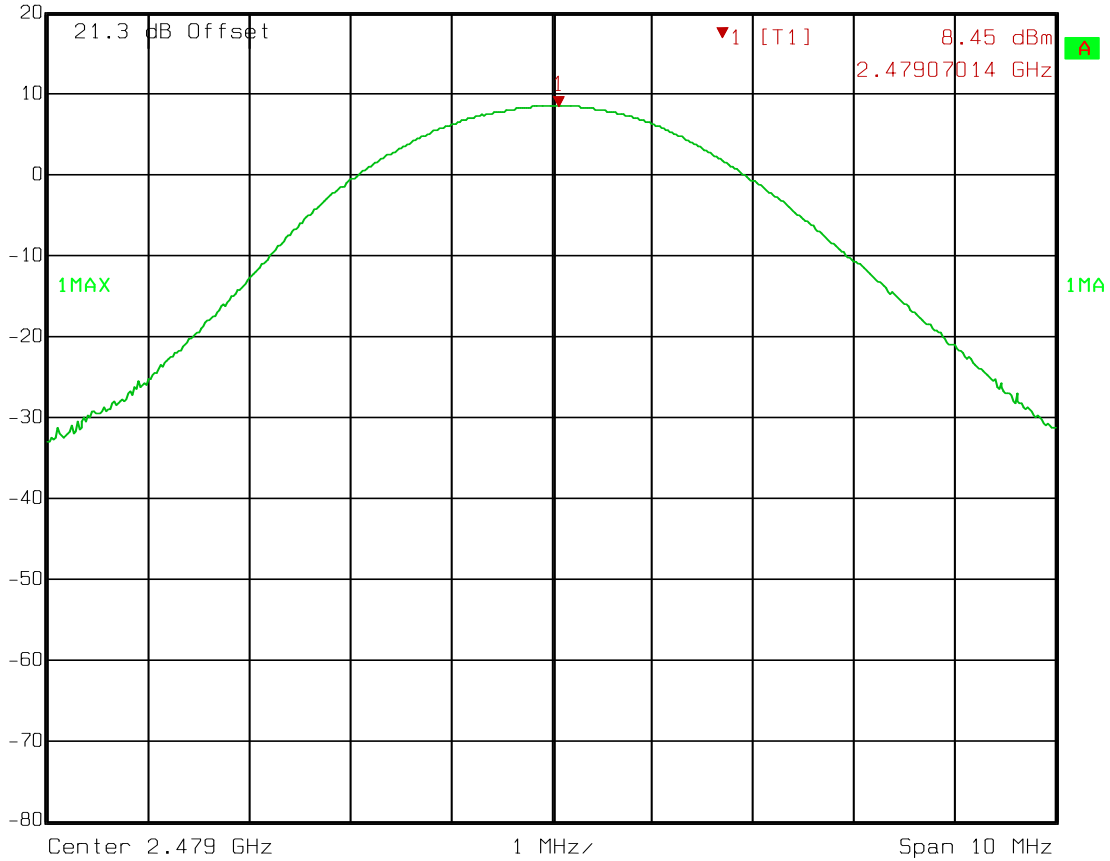

Date: 29.JAN.2013 10:51:51

Test Data

Power
Low Channel



Marker 1 [T1] RBW 3 MHz RF Att 20 dB
8.27 dBm VBW 10 MHz
20 dBm 0.000000 s SWT 5 ms Unit dBm

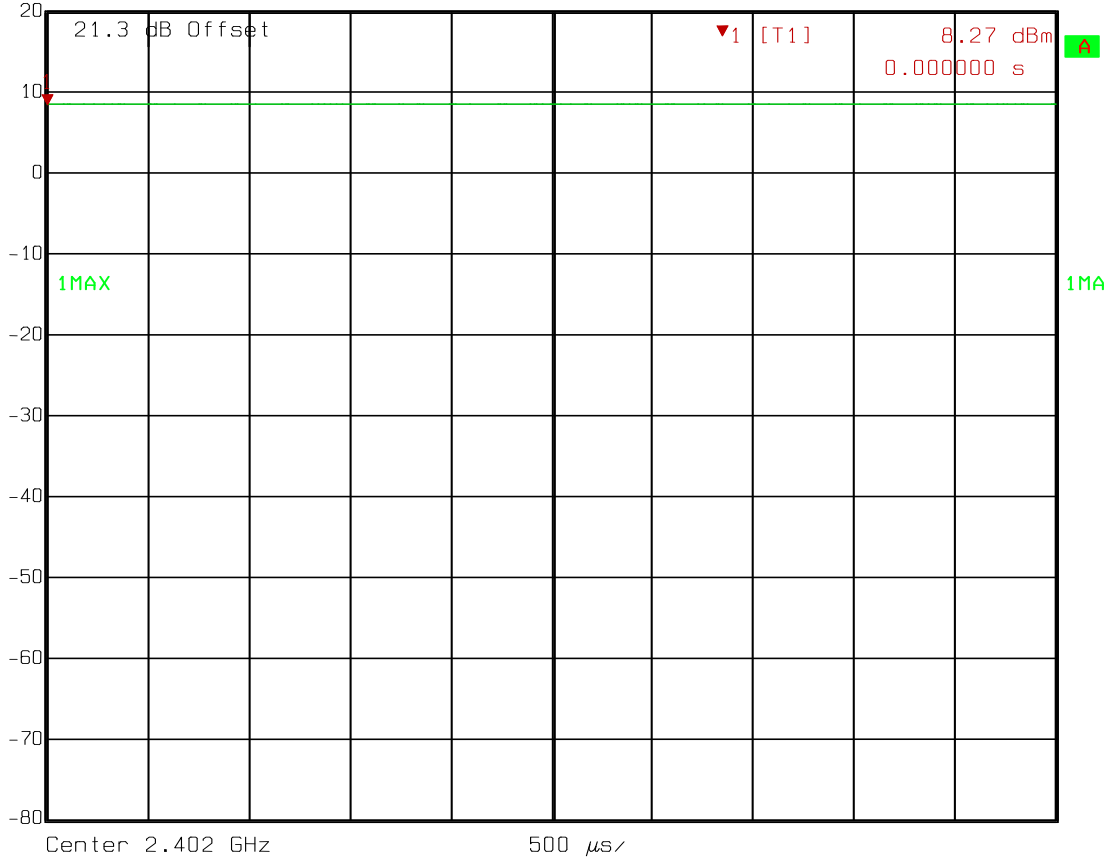

Date: 29.JAN.2013 11:56:37

EQUIPMENT: CC256x QFN EM

PROJECT NO.:10238472RUS1

Test Data

Power
Mid Channel



Marker 1 [T1] RBW 3 MHz RF Att 20 dB
Ref Lvl 8.38 dBm VBW 10 MHz
20 dBm 350.701403 μ s SWT 5 ms Unit dBm

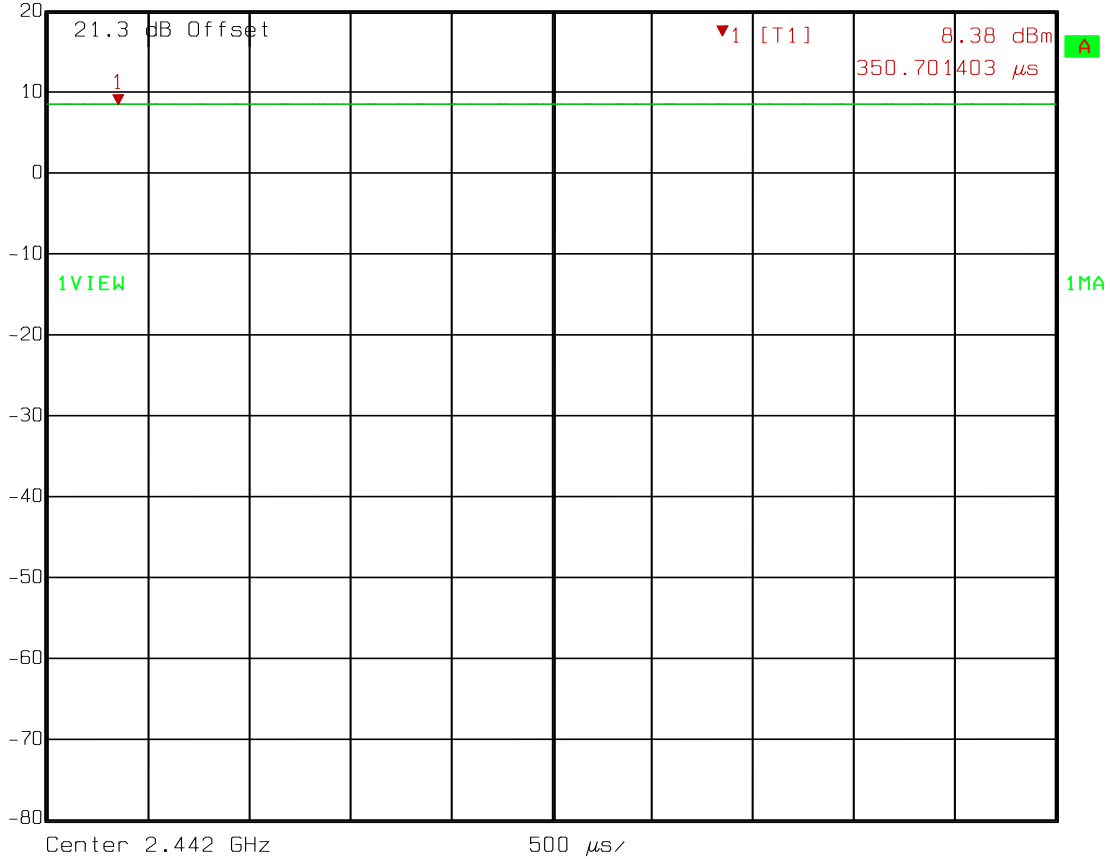

Date: 29.JAN.2013 11:57:18

Test Data

Power
High Channel



Marker 1 [T1] RBW 3 MHz RF Att 20 dB
Ref Lvl 8.16 dBm VBW 10 MHz
20 dBm 350.701403 μ s SWT 5 ms Unit dBm

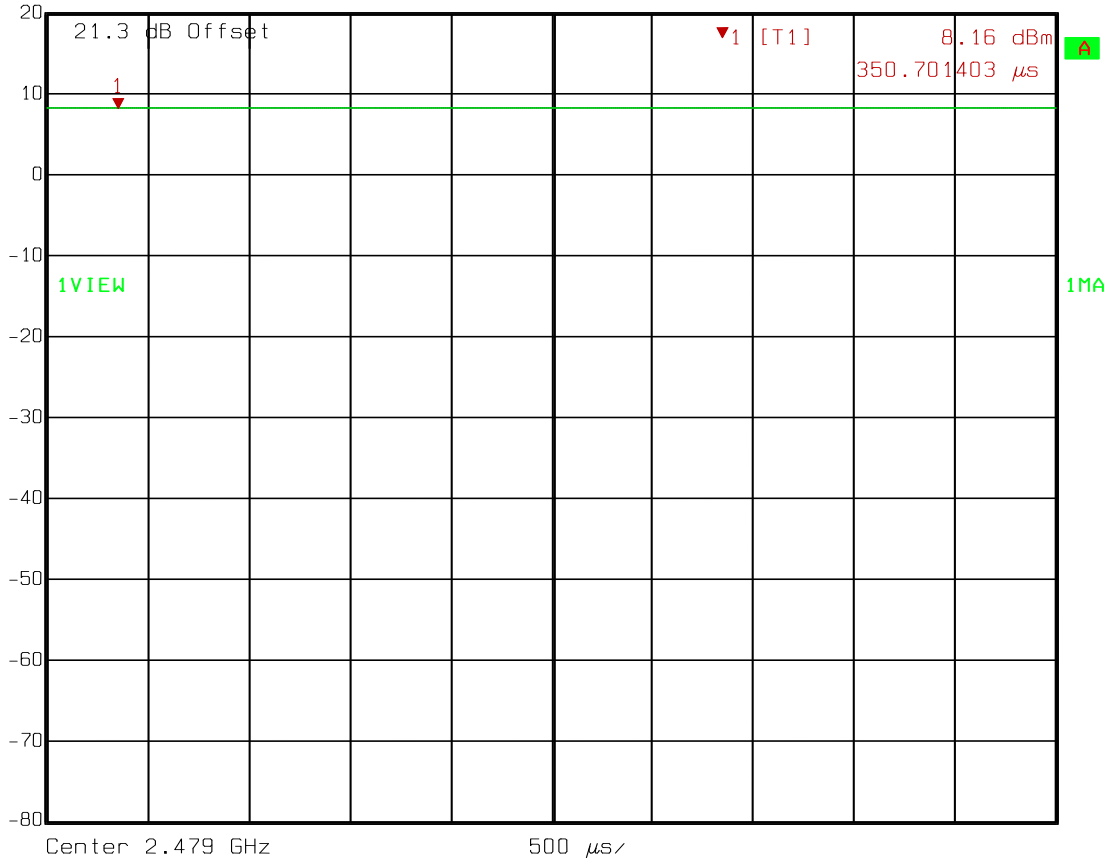

Date: 29.JAN.2013 11:57:52

EQUIPMENT: CC256x QFN EM

PROJECT NO.:10238472RUS1

Section 6. Spurious Emissions (Antenna Conducted)

NAME OF TEST: Spurious Emissions (Conducted)	PARA. NO.: 15.247(d) A8.5
TESTED BY: David Light	DATE: 29 January 2013

Test Results: Complies.

Measurement Data: See attached plots.

Equipment Used: 1036-1082-1472

Measurement Uncertainty: 1X10⁻⁷ppm

Temperature: 22 °C

Relative Humidity: 60 %

Test Data – Spurious Emissions at Antenna Terminals

Lower Band Edge

GFSK

 Delta 1 [T1] RBW 100 kHz RF Att 20 dB
Ref Lvl 55.00 dB VBW 300 kHz
20 dBm 2.00901804 MHz SWT 5 ms Unit dBm

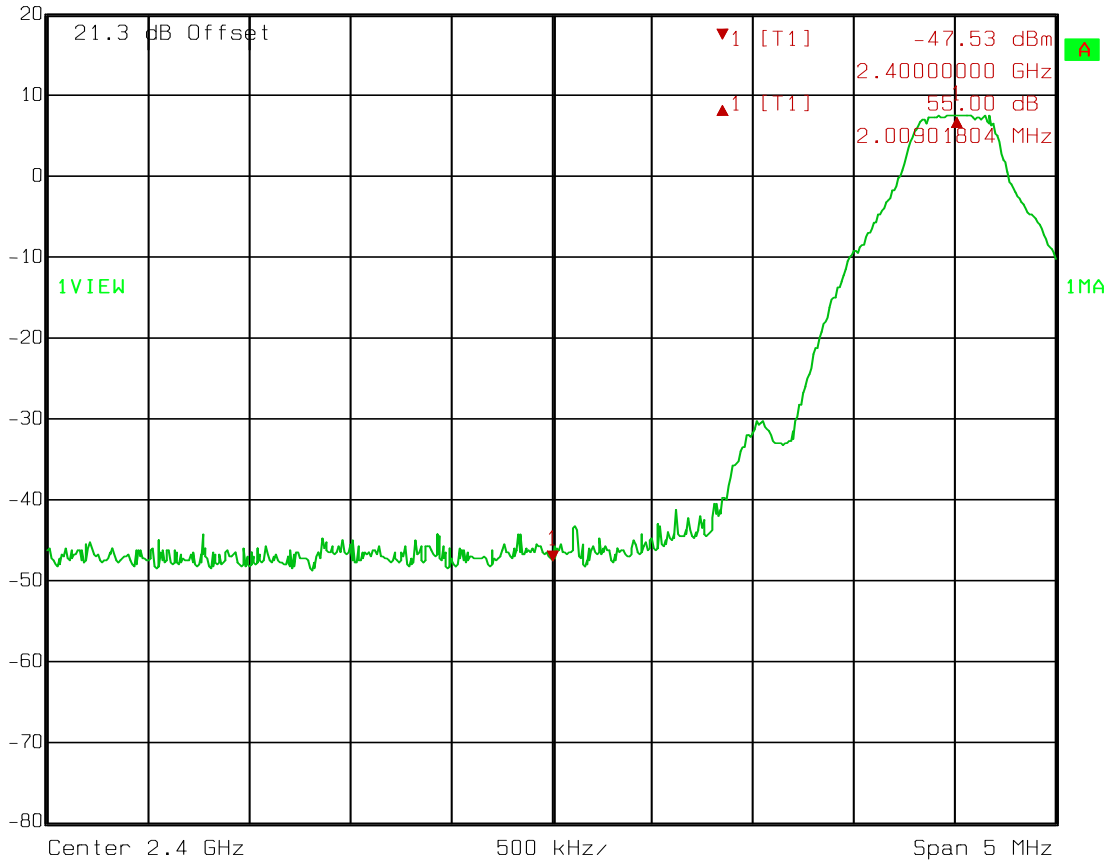

Date: 29.JAN.2013 12:24:13

Test Data – Spurious Emissions at Antenna Terminals

Lower Band Edge
EDR2



Delta 1 [T1] RBW 100 kHz RF Att 20 dB
Ref Lvl 46.91 dB VBW 300 kHz
20 dBm 2.03907816 MHz SWT 5 ms Unit dBm

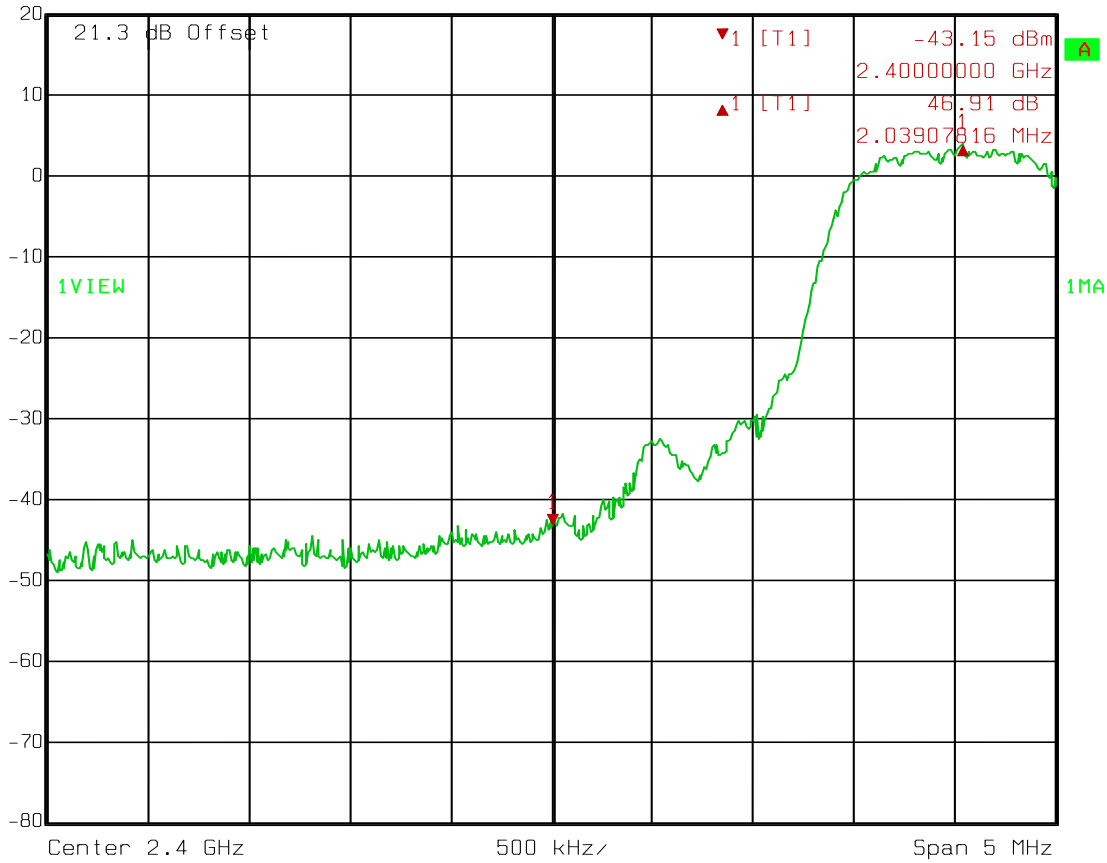

Date: 29.JAN.2013 12:25:12

Test Data – Spurious Emissions at Antenna Terminals

Lower Band Edge
EDR3



Ref Lvl	Delta 1 [T1]	RBW	100 kHz	RF Att	20 dB
20 dBm	48.91 dB	VBW	300 kHz		
	1.83867735 MHz	SWT	5 ms	Unit	dBm

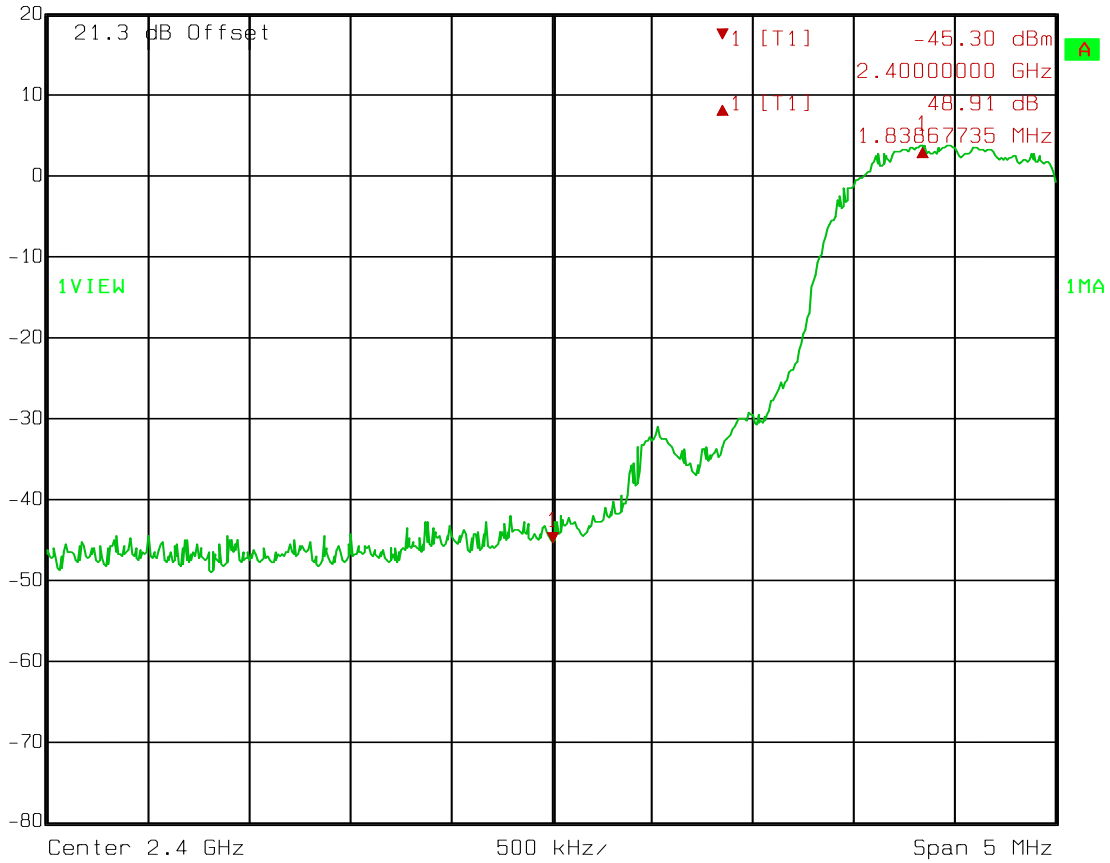

Date: 29.JAN.2013 12:25:43

Test Data – Spurious Emissions at Antenna Terminals

Lower Band Edge
Bluetooth Low Energy



Delta 1 [T1] RBW 100 kHz RF Att 20 dB
Ref Lvl 53.76 dB VBW 300 kHz
20 dBm 2.24949900 MHz SWT 5 ms Unit dBm

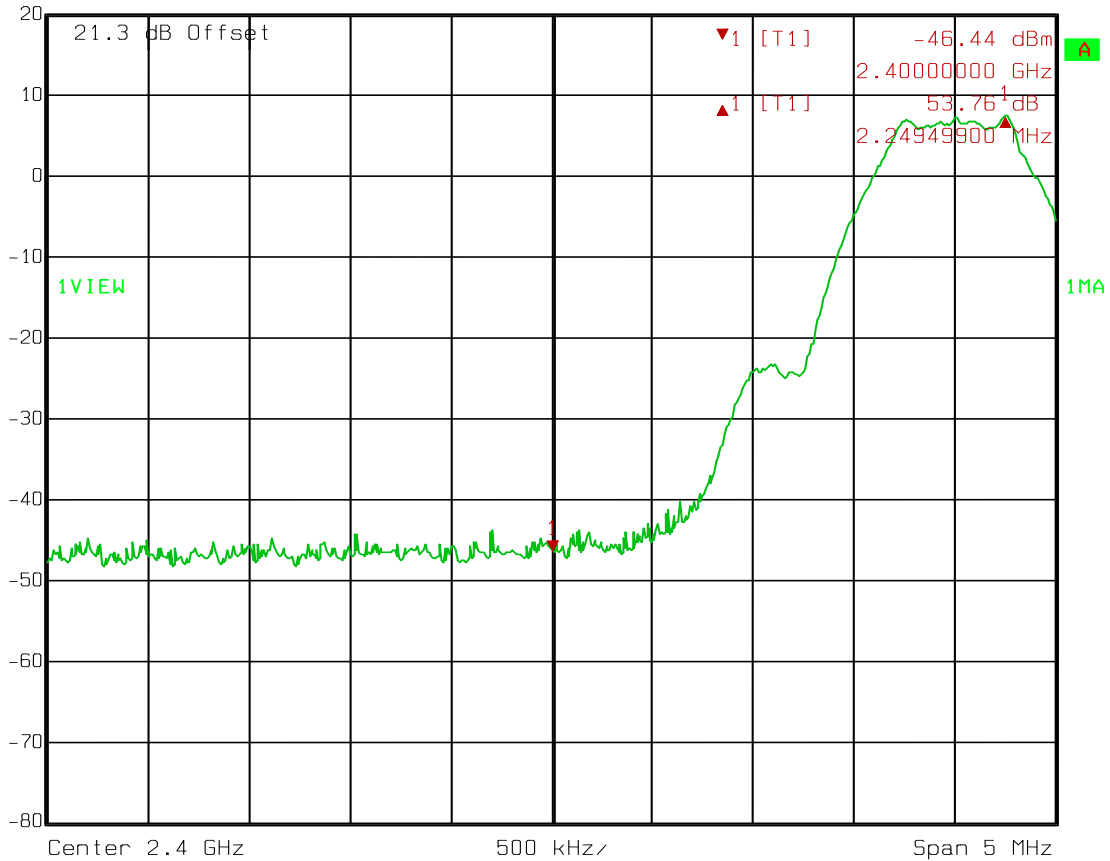

Date: 29.JAN.2013 12:21:10

Test Data – Spurious Emissions at Antenna Terminals

Spurious Emissions

Low Channel

GFSK



Delta 1 [T1] RBW 100 kHz RF Att 20 dB
Ref Lvl -47.66 dB VBW 100 kHz
20 dBm 4.18153173 GHz SWT 6.4 s Unit dBm

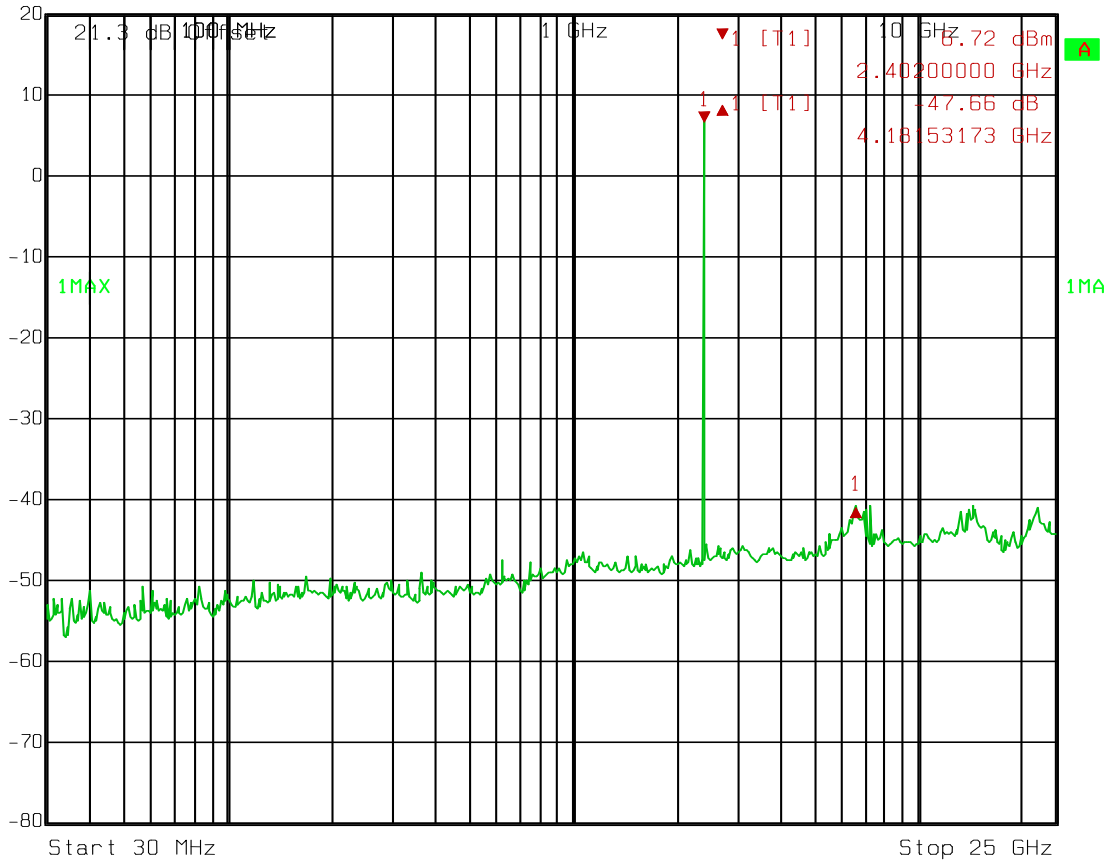

Date: 29. JAN. 2013 11:19:41

Test Data – Spurious Emissions at Antenna Terminals

Spurious Emissions
Mid Channel
GFSK

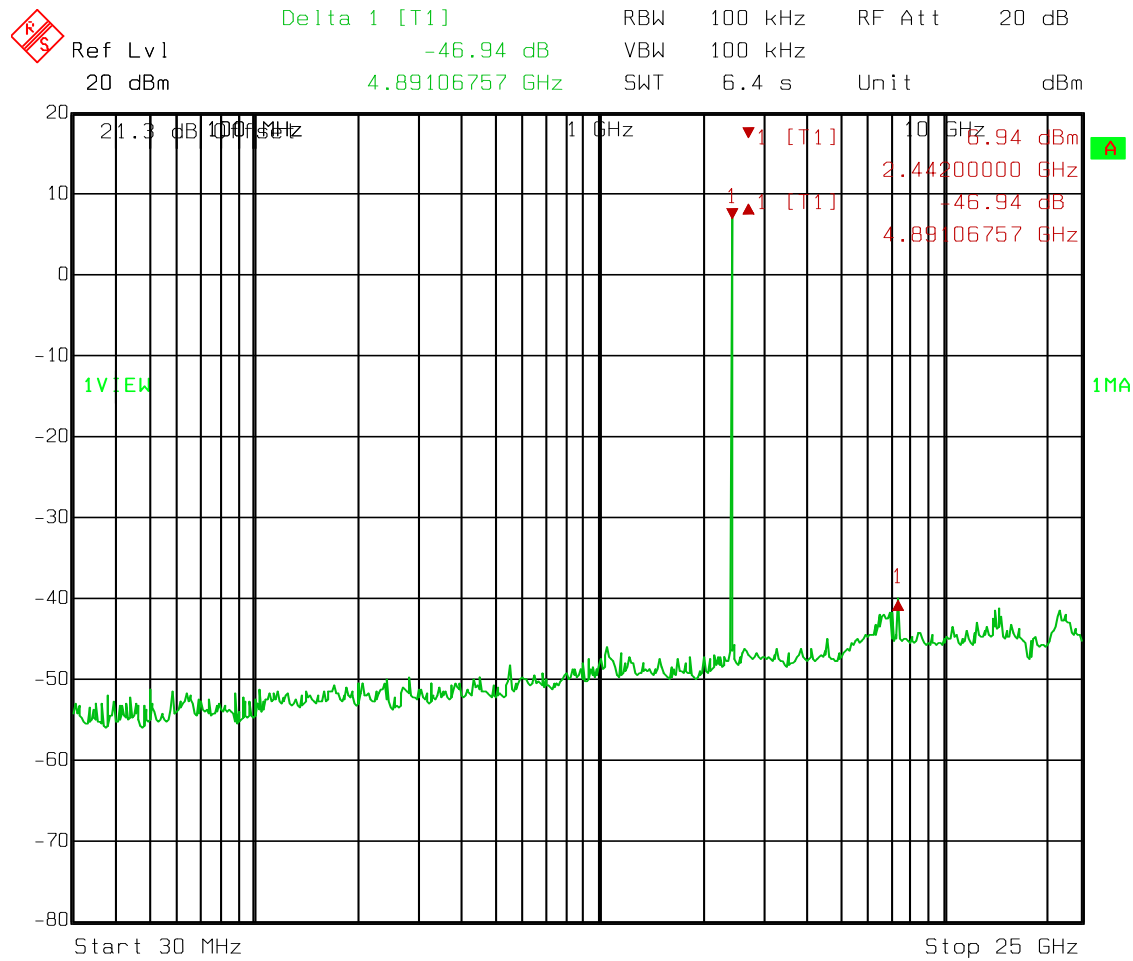

Date: 29.JAN.2013 11:20:31

Test Data – Spurious Emissions at Antenna Terminals

Spurious Emissions
High Channel
GFSK

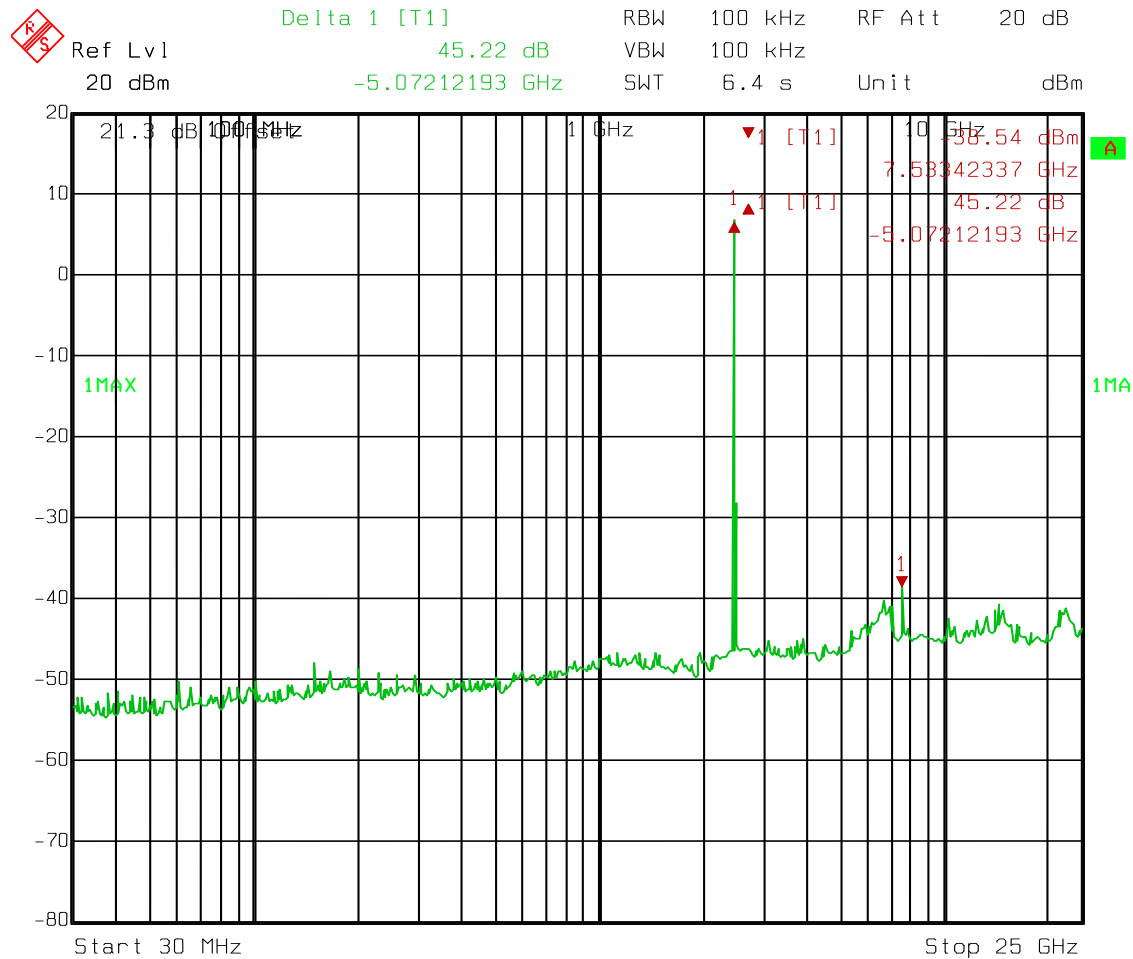

Date: 29.JAN.2013 11:21:34

Test Data – Spurious Emissions at Antenna Terminals

Spurious Emissions
Low Channel
EDR2

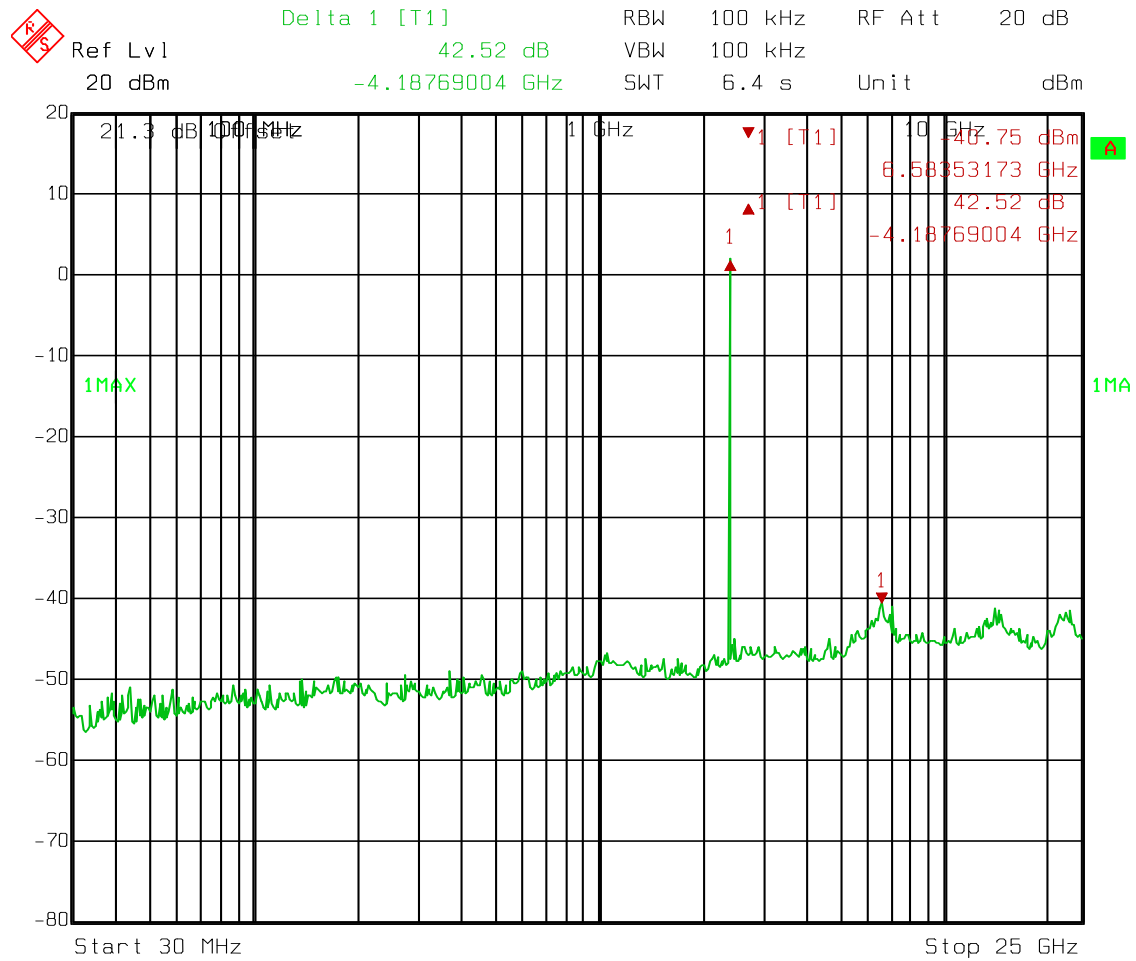

Date: 29.JAN.2013 11:22:19

Test Data – Spurious Emissions at Antenna Terminals

Spurious Emissions
Mid Channel
EDR2

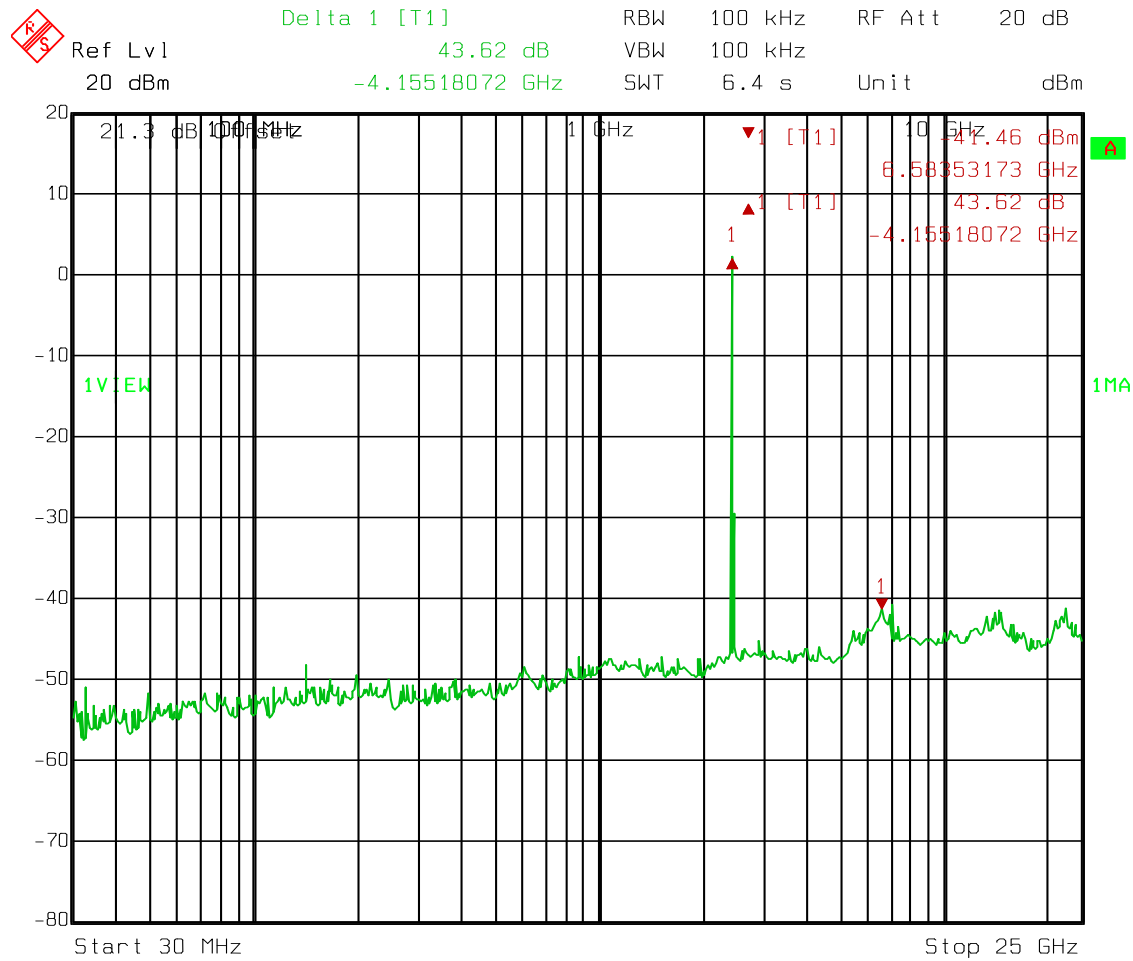

Date: 29.JAN.2013 11:22:57

Test Data – Spurious Emissions at Antenna Terminals

Spurious Emissions
High Channel
EDR2

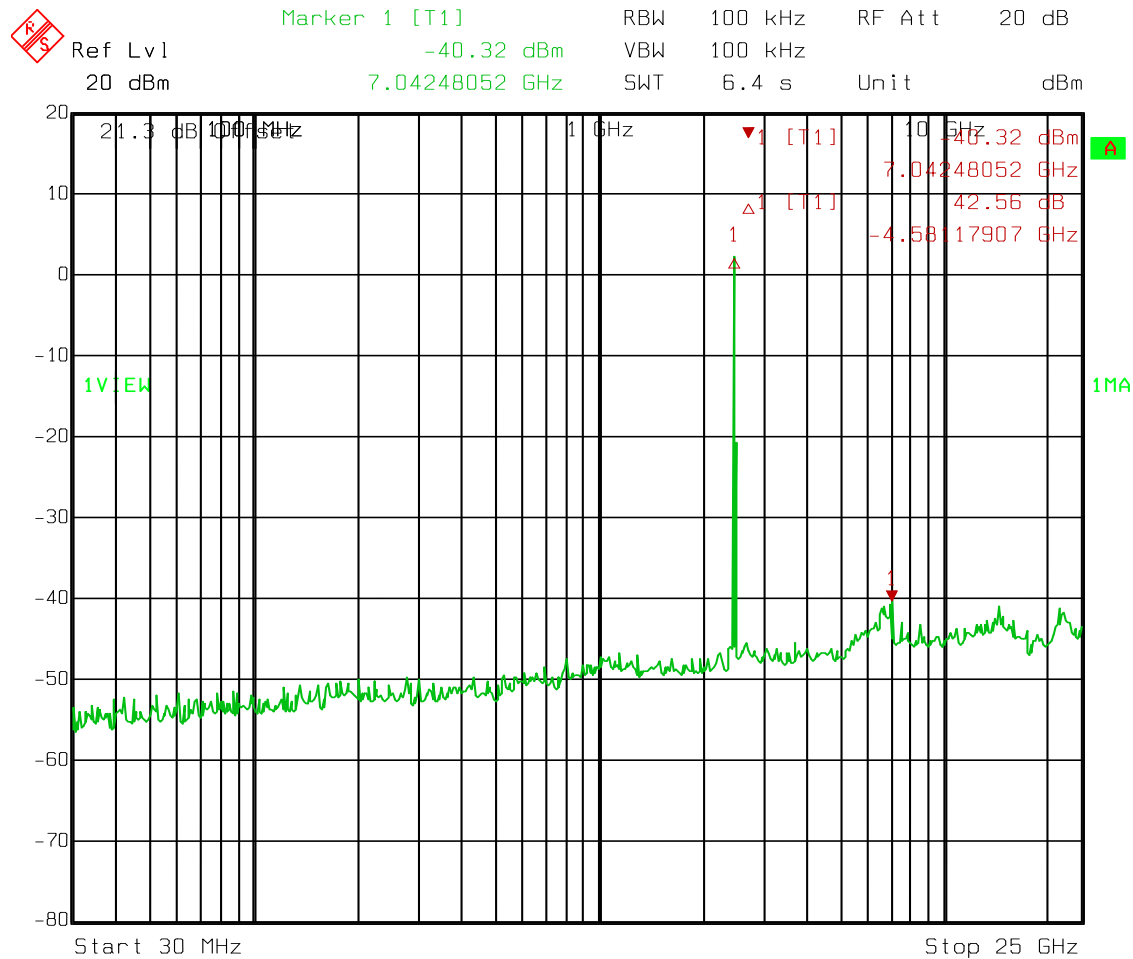

Date: 29.JAN.2013 11:23:36

Test Data – Spurious Emissions at Antenna Terminals

Spurious Emissions
Low Channel
EDR3

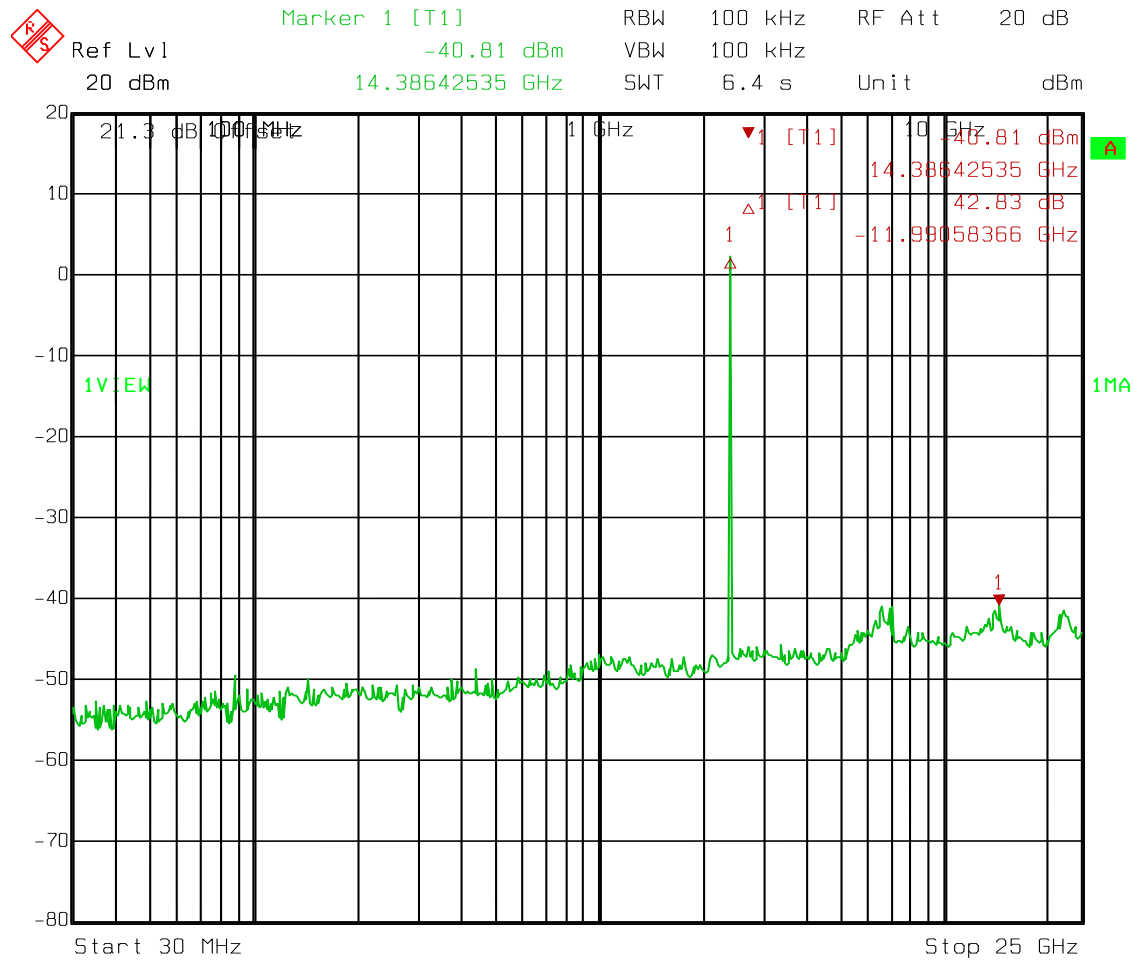

Date: 29.JAN.2013 11:24:37

Test Data – Spurious Emissions at Antenna Terminals

Spurious Emissions
Mid Channel
EDR3

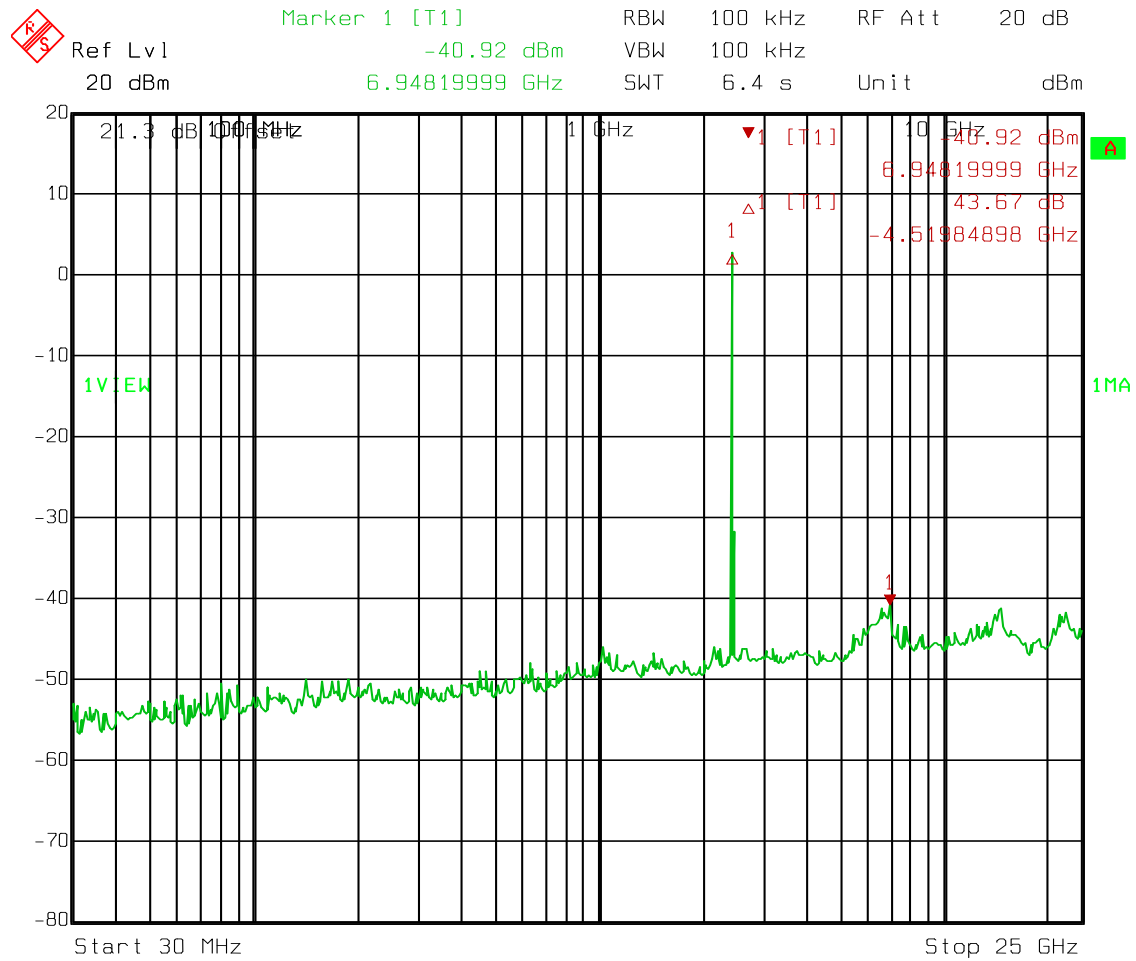

Date: 29.JAN.2013 11:25:20

Test Data – Spurious Emissions at Antenna Terminals

Spurious Emissions
High Channel
EDR3

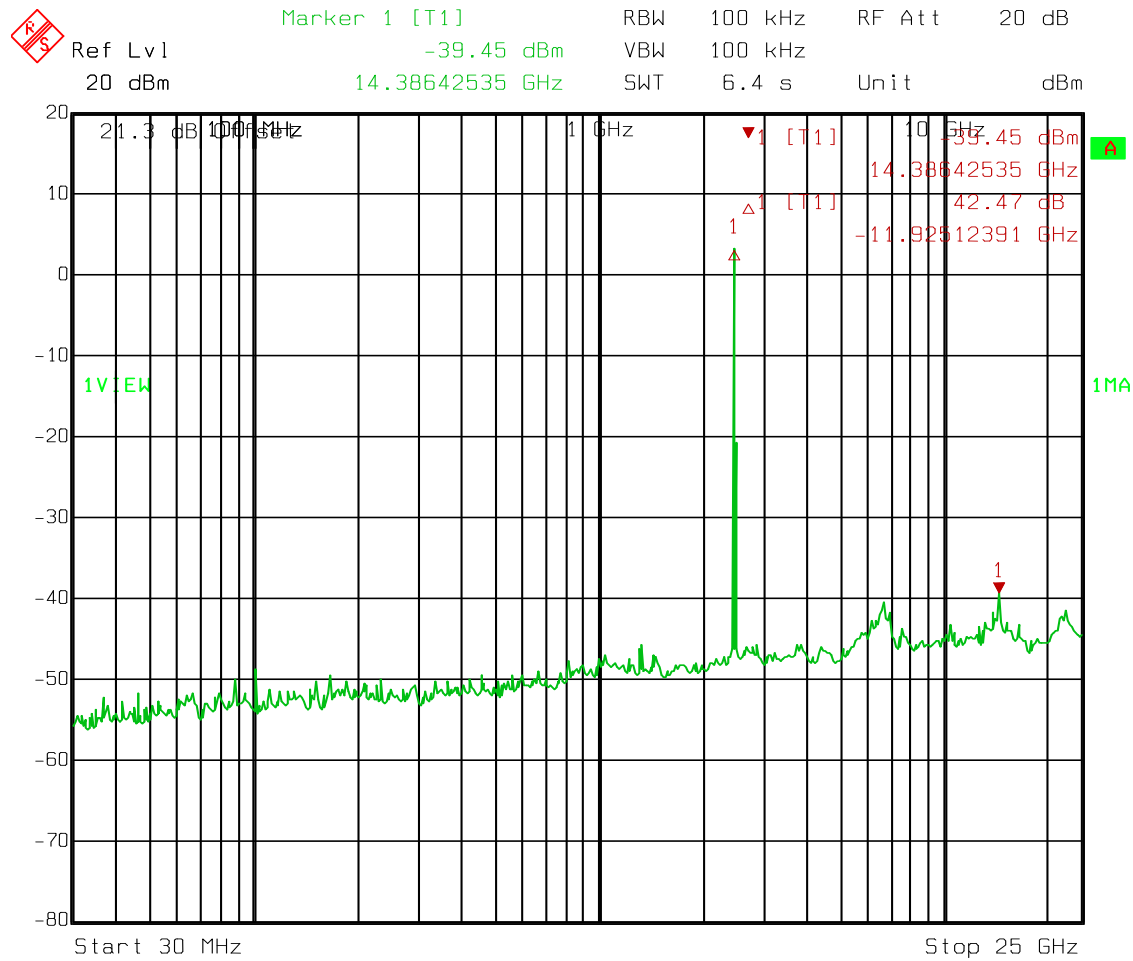

Date: 29.JAN.2013 11:25:58

Test Data – Spurious Emissions at Antenna Terminals

Spurious Emissions

Low Channel

Bluetooth Low Energy



Delta 1 [T1] RBW 100 kHz RF Att 20 dB
Ref Lvl 45.36 dB VBW 300 kHz
20 dBm -4.83905514 GHz SWT 6.4 s Unit dBm

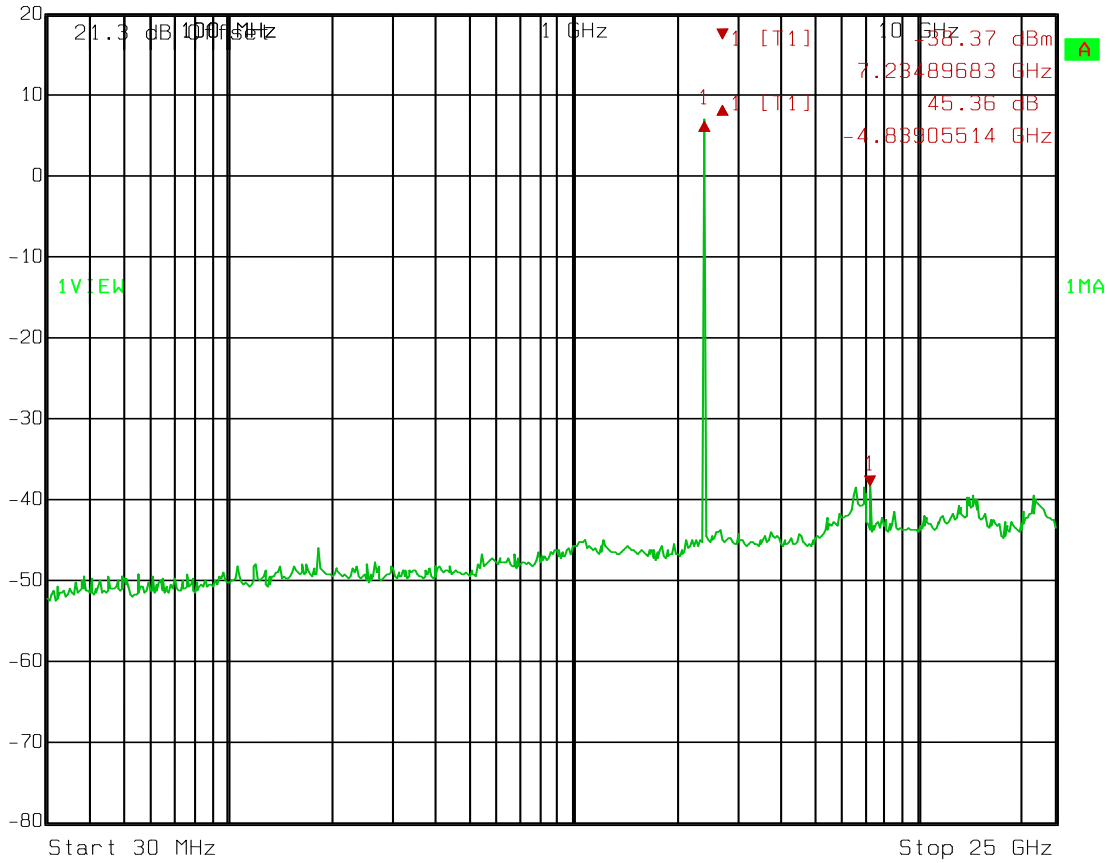

Date: 29.JAN.2013 12:18:22

Test Data – Spurious Emissions at Antenna Terminals

Spurious Emissions
Mid Channel
Bluetooth Low Energy

 Delta 1 [T1] RBW 100 kHz RF Att 20 dB
Ref Lvl 46.85 dB VBW 300 kHz
20 dBm -4.24451305 GHz SWT 6.4 s Unit dBm

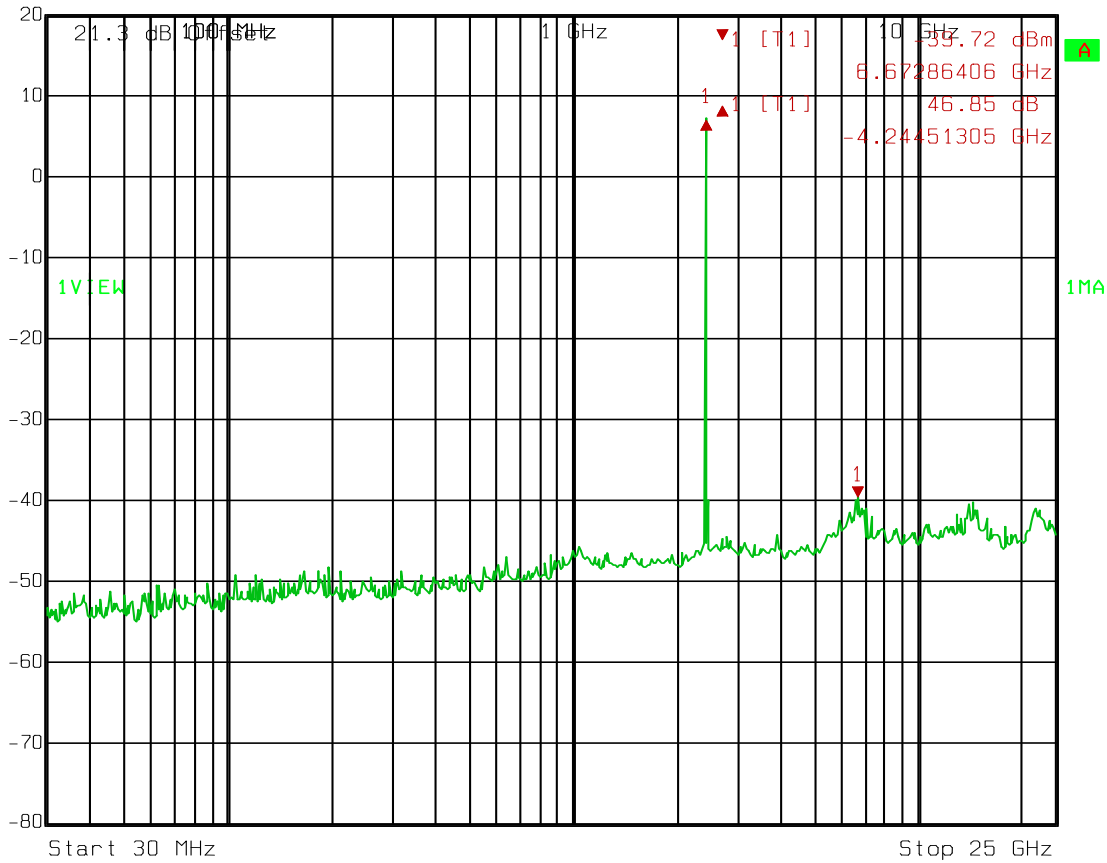

Date: 29.JAN.2013 12:19:16

Test Data – Spurious Emissions at Antenna Terminals

Spurious Emissions
High Channel
Bluetooth Low Energy

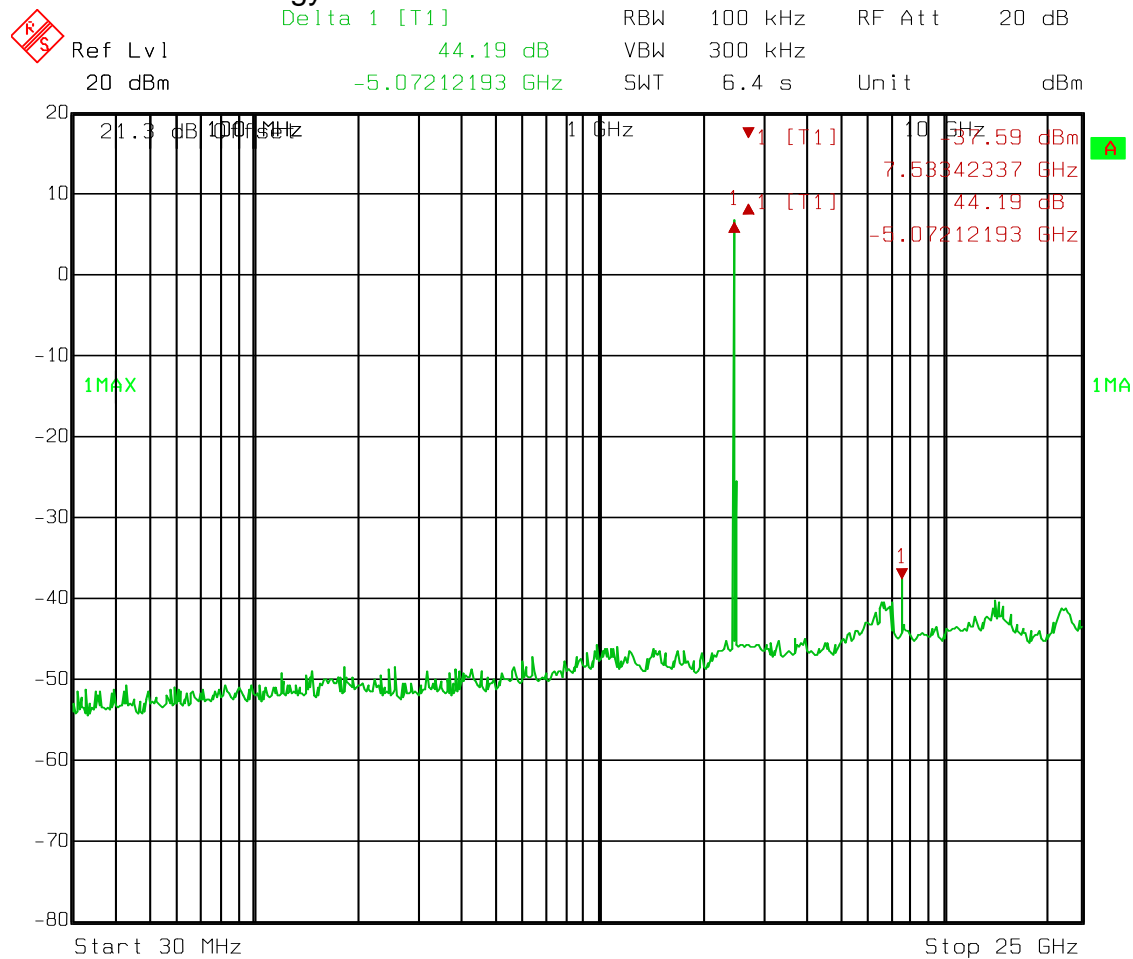

Date: 29.JAN.2013 12:19:56

Section 7. Spurious Emissions (Radiated)

NAME OF TEST: Spurious Emissions (Radiated)	PARA. NO.: 15.247(d) RSS-Gen 7.2.2
TESTED BY: David Light	DATE: 30 January 2013

Test Results: Complies. The worst case emission was 52.1 dBµV/m at 2483.5 MHz. This is 1.9 dB below the average specification limit of 54 dBµV/m. This was a peak measurement.

Measurement Data: See attached table.

Duty Cycle Calculation:

Duty Cycle correction factor(dB) = 20 log (rf_{ON} in ms/100ms)

Notes:

- For handheld devices, the EUT was tested on three orthogonal axis'
- The device was tested from 30 MHz to the tenth harmonic of the highest fundamental frequency per 15.33
- The device was tested on three channels per 15.31(l).
- No emissions were detected within 20 dB of the specification limit therefore none are reported per 15.31(o). Band edge data is presented below.

Equipment Used: 993-1036-1016-791-1480-1783

Measurement Uncertainty: +/-3.6 dB

Temperature: 20 °C

Relative Humidity: 41 %

Test Data - Radiated Emissions

GFSK

Meas. Freq. (MHz)	Ant. Pol. (H/V)	Duty Cycle (dB)	Meter Reading (dBuV)	Antenna Factor (dB)	Path Loss (dB)	RF Gain (dB)	Corrected Reading (dBuV/m)	Spec. limit (dBuV/m)	CR/SL Diff. (dB)	Pass Fail Unc.	Comment
											GFSK 2442 MHz
4884	V		54.6	34	4.3	31.5	61.4	74.0	-12.6	Pass	
4884	V	-20	54.6	34	4.3	31.5	41.4	54.0	-12.6	Pass	
7326	V		45	36.6	5.3	31.3	55.6	74.0	-18.4	Pass	
7326	V	-20	45	36.6	5.3	31.3	35.6	54.0	-18.4	Pass	
4884	H		47.5	34	4.3	31.5	54.3	74.0	-19.7	Pass	
4884	H	-20	47.5	34	4.3	31.5	34.3	54.0	-19.7	Pass	
7326	H		49	36.6	5.3	31.3	59.6	74.0	-14.4	Pass	
7326	H	-20	49	36.6	5.3	31.3	39.6	54.0	-14.4	Pass	
											GFSK 2402 MHz
4804	V		53.3	34	4.3	31.5	60.1	74.0	-13.9	Pass	
4804	V	-20	53.3	34	4.3	31.5	40.1	54.0	-13.9	Pass	
7206	V		47	36.6	5.3	31.3	57.6	74.0	-16.4	Pass	
7206	V	-20	47	36.6	5.3	31.3	37.6	54.0	-16.4	Pass	
4804	H		47	34	4.3	31.5	53.8	74.0	-20.2	Pass	
4804	H	-20	47	34	4.3	31.5	33.8	54.0	-20.2	Pass	
7206	H		49	36.6	5.3	31.3	59.6	74.0	-14.4	Pass	
7206	H	-20	49	36.6	5.3	31.3	39.6	54.0	-14.4	Pass	
											GFSK 2480 MHz
2483.5	H		52	28.8	3.1	31.8	52.1	54.0	-1.9	Pass	
4960	H		49.7	34	4.3	31.5	56.5	74.0	-17.5	Pass	
4960	H	-20	49.7	34	4.3	31.5	36.5	54.0	-17.5	Pass	
7440	H		50.6	36.6	5.3	31.3	61.2	74.0	-12.8	Pass	
7440	H	-20	50.6	36.6	5.3	31.3	41.2	54.0	-12.8	Pass	
2483.5	V		49.9	28.8	3.1	31.8	50.0	54.0	-4.0	Pass	
4960	V		57	34	4.3	31.5	63.8	74.0	-10.2	Pass	
4960	V	-20	57	34	4.3	31.5	43.8	54.0	-10.2	Pass	
7440	V		47	36.6	5.3	31.3	57.6	74.0	-16.4	Pass	
7440	V	-20	47	36.6	5.3	31.3	37.6	54.0	-16.4	Pass	

Test Data - Radiated Emissions

EDR2

Meas. Freq. (MHz)	Ant. Pol. (H/V)	Duty Cycle (dB)	Meter Reading (dBUV)	Antenna Factor (dB)	Path Loss (dB)	RF Gain (dB)	Corrected Reading (dBUV/m)	Spec. limit (dBUV/m)	CR/SL Diff. (dB)	Pass Fail Unc.	Comment
EDR2 2402 MHz											
4804	V		51.6	34	4.3	31.5	58.4	74.0	-15.6	Pass	
4804	V	-20	51.6	34	4.3	31.5	38.4	54.0	-15.6	Pass	
7206	V		46	36.6	5.3	31.3	56.6	74.0	-17.4	Pass	
7206	V	-20	46	36.6	5.3	31.3	36.6	54.0	-17.4	Pass	
4804	H		45	34	4.3	31.5	51.8	74.0	-22.2	Pass	
4804	H	-20	45	34	4.3	31.5	31.8	54.0	-22.2	Pass	
7206	H		47	36.6	5.3	31.3	57.6	74.0	-16.4	Pass	
7206	H	-20	47	36.6	5.3	31.3	37.6	54.0	-16.4	Pass	
EDR2 2442 MHz											
4884	V		52.5	34	4.3	31.5	59.3	74.0	-14.7	Pass	
4884	V	-20	52.5	34	4.3	31.5	39.3	54.0	-14.7	Pass	
7326	V		45.6	36.6	5.3	31.3	56.2	74.0	-17.8	Pass	
7326	V	-20	45.6	36.6	5.3	31.3	36.2	54.0	-17.8	Pass	
4884	H		46.3	34	4.3	31.5	53.1	74.0	-20.9	Pass	
4884	H	-20	46.3	34	4.3	31.5	33.1	54.0	-20.9	Pass	
7326	H		49	36.6	5.3	31.3	59.6	74.0	-14.4	Pass	
7326	H	-20	49	36.6	5.3	31.3	39.6	54.0	-14.4	Pass	
EDR2 2480 MHz											
2483.5	V		62	28.8	3.1	31.8	62.1	74.0	-11.9	Pass	
2483.5	V	-20	62	28.8	3.1	31.8	42.1	54.0	-11.9	Pass	
4960	V		55	34	4.3	31.5	61.8	74.0	-12.2	Pass	
4960	V	-20	55	34	4.3	31.5	41.8	54.0	-12.2	Pass	
7440	V		45	36.6	5.3	31.3	55.6	74.0	-18.4	Pass	
7440	V	-20	45	36.6	5.3	31.3	35.6	54.0	-18.4	Pass	
2483.5	H		55	28.8	3.1	31.8	55.1	74.0	-18.9	Pass	
2483.5	H	-20	55	28.8	3.1	31.8	35.1	54.0	-18.9	Pass	
4960	H		49	34	4.3	31.5	55.8	74.0	-18.2	Pass	
4960	H	-20	49	34	4.3	31.5	35.8	54.0	-18.2	Pass	
7440	H		49.6	36.6	5.3	31.3	60.2	74.0	-13.8	Pass	
7440	H	-20	49.6	36.6	5.3	31.3	40.2	54.0	-13.8	Pass	

Test Data - Radiated Emissions

EDR3

Meas. Freq. (MHz)	Ant. Pol. (H/V)	Duty Cycle (dB)	Meter Reading (dBuV)	Antenna Factor (dB)	Path Loss (dB)	RF Gain (dB)	Corrected Reading (dBuV/m)	Spec. limit (dBuV/m)	CR/SL Diff. (dB)	Pass Fail Unc.	Comment
EDR3 2402 MHz											
4804	V		52.6	34	4.3	31.5	59.4	74.0	-14.6	Pass	
4804	V	-20	52.6	34	4.3	31.5	39.4	54.0	-14.6	Pass	
7206	V		46	36.6	5.3	31.3	56.6	74.0	-17.4	Pass	
7206	V	-20	46	36.6	5.3	31.3	36.6	54.0	-17.4	Pass	
4804	H		46	34	4.3	31.5	52.8	74.0	-21.2	Pass	
4804	H	-20	46	34	4.3	31.5	32.8	54.0	-21.2	Pass	
7206	H		46	36.6	5.3	31.3	56.6	74.0	-17.4	Pass	
7206	H	-20	46	36.6	5.3	31.3	36.6	54.0	-17.4	Pass	
EDR3 2442 MHz											
4884	V		53	34	4.3	31.5	59.8	74.0	-14.2	Pass	
4884	V	-20	53	34	4.3	31.5	39.8	54.0	-14.2	Pass	
7326	V		46	36.6	5.3	31.3	56.6	74.0	-17.4	Pass	
7326	V	-20	46	36.6	5.3	31.3	36.6	54.0	-17.4	Pass	
4884	H		47	34	4.3	31.5	53.8	74.0	-20.2	Pass	
4884	H	-20	47	34	4.3	31.5	33.8	54.0	-20.2	Pass	
7326	H		48	36.6	5.3	31.3	58.6	74.0	-15.4	Pass	
7326	H	-20	48	36.6	5.3	31.3	38.6	54.0	-15.4	Pass	
EDR3 2480 MHz											
2483.5	V		56.5	28.8	3.1	31.8	56.6	74.0	-17.4	Pass	
2483.5	V	-20	56.5	28.8	3.1	31.8	36.6	54.0	-17.4	Pass	
4960	V		54.7	34	4.3	31.5	61.5	74.0	-12.5	Pass	
4960	V	-20	54.7	34	4.3	31.5	41.5	54.0	-12.5	Pass	
7440	V		46	36.6	5.3	31.3	56.6	74.0	-17.4	Pass	
7440	V	-20	46	36.6	5.3	31.3	36.6	54.0	-17.4	Pass	
2483.5	H		61.5	28.8	3.1	31.8	61.6	74.0	-12.4	Pass	
2483.5	H	-20	61.5	28.8	3.1	31.8	41.6	54.0	-12.4	Pass	
4960	H		48	34	4.3	31.5	54.8	74.0	-19.2	Pass	
4960	H	-20	48	34	4.3	31.5	34.8	54.0	-19.2	Pass	
7440	H		50	36.6	5.3	31.3	60.6	74.0	-13.4	Pass	
7440	H	-20	50	36.6	5.3	31.3	40.6	54.0	-13.4	Pass	

Test Data - Radiated Emissions

Bluetooth Low Energy

Meas. Freq. (MHz)	Ant. Pol. (H/V)	Duty Cycle (dB)	Meter Reading (dBuV)	Antenna Factor (dB)	Path Loss (dB)	RF Gain (dB)	Corrected Reading (dBuV/m)	Spec. limit (dBuV/m)	CR/SL Diff. (dB)	Pass Fail Unc.	Comment
											BLE Low Ch
4804	V		53	34	4.3	31.5	59.8	74.0	-14.2	Pass	
4804	V	-20	53	34	4.3	31.5	39.8	54.0	-14.2	Pass	
7206	V		47	36.6	5.3	31.3	57.6	74.0	-16.4	Pass	
7206	V	-20	47	36.6	5.3	31.3	37.6	54.0	-16.4	Pass	
4804	H		47	34	4.3	31.5	53.8	74.0	-20.2	Pass	
4804	H	-20	47	34	4.3	31.5	33.8	54.0	-20.2	Pass	
7206	H		47.8	36.6	5.3	31.3	58.4	74.0	-15.6	Pass	
7206	H	-20	47.8	36.6	5.3	31.3	38.4	54.0	-15.6	Pass	
											BLE Mid Ch
4884	V		54	34	4.3	31.5	60.8	74.0	-13.2	Pass	
4884	V	-20	54	34	4.3	31.5	40.8	54.0	-13.2	Pass	
7326	V		47.3	36.6	5.3	31.3	57.9	74.0	-16.1	Pass	
7326	V	-20	47.3	36.6	5.3	31.3	37.9	54.0	-16.1	Pass	
4884	H		49	34	4.3	31.5	55.8	74.0	-18.2	Pass	
4884	H	-20	49	34	4.3	31.5	35.8	54.0	-18.2	Pass	
7326	H		49	36.6	5.3	31.3	59.6	74.0	-14.4	Pass	
7326	H	-20	49	36.6	5.3	31.3	39.6	54.0	-14.4	Pass	
											BLE High Ch
2483.5	V		48.3	28.8	3.1	31.8	48.4	74.0	-25.6	Pass	
2483.5	V	-20	48.3	28.8	3.1	31.8	28.4	54.0	-25.6	Pass	
4960	V		56	34	4.3	31.5	62.8	74.0	-11.2	Pass	
4960	V	-20	56	34	4.3	31.5	42.8	54.0	-11.2	Pass	
7440	V		47	36.6	5.3	31.3	57.6	74.0	-16.4	Pass	
7440	V	-20	47	36.6	5.3	31.3	37.6	54.0	-16.4	Pass	
2483.5	H		54	28.8	3.1	31.8	54.1	74.0	-19.9	Pass	
2483.5	H	-20	54	28.8	3.1	31.8	34.1	54.0	-19.9	Pass	
4960	H		49.3	34	4.3	31.5	56.1	74.0	-17.9	Pass	
4960	H	-20	49.3	34	4.3	31.5	36.1	54.0	-17.9	Pass	
7440	H		50	36.6	5.3	31.3	60.6	74.0	-13.4	Pass	
7440	H	-20	50	36.6	5.3	31.3	40.6	54.0	-13.4	Pass	

Test Data - Radiated Emissions

Duty Cycle Correction (Bluetooth)

One Hop

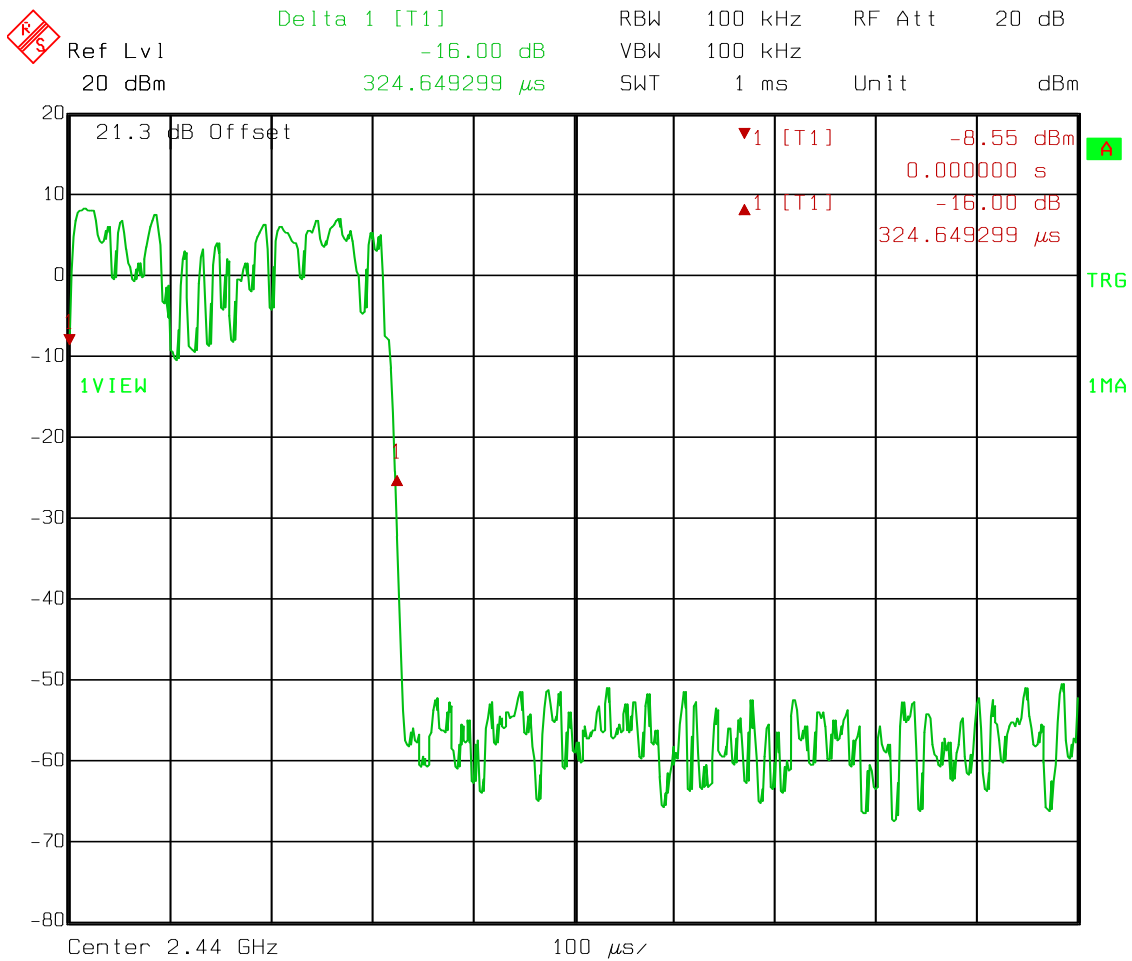

Date: 29.JAN.2013 11:34:01

Test Data - Radiated Emissions
Duty Cycle Correction (Bluetooth)

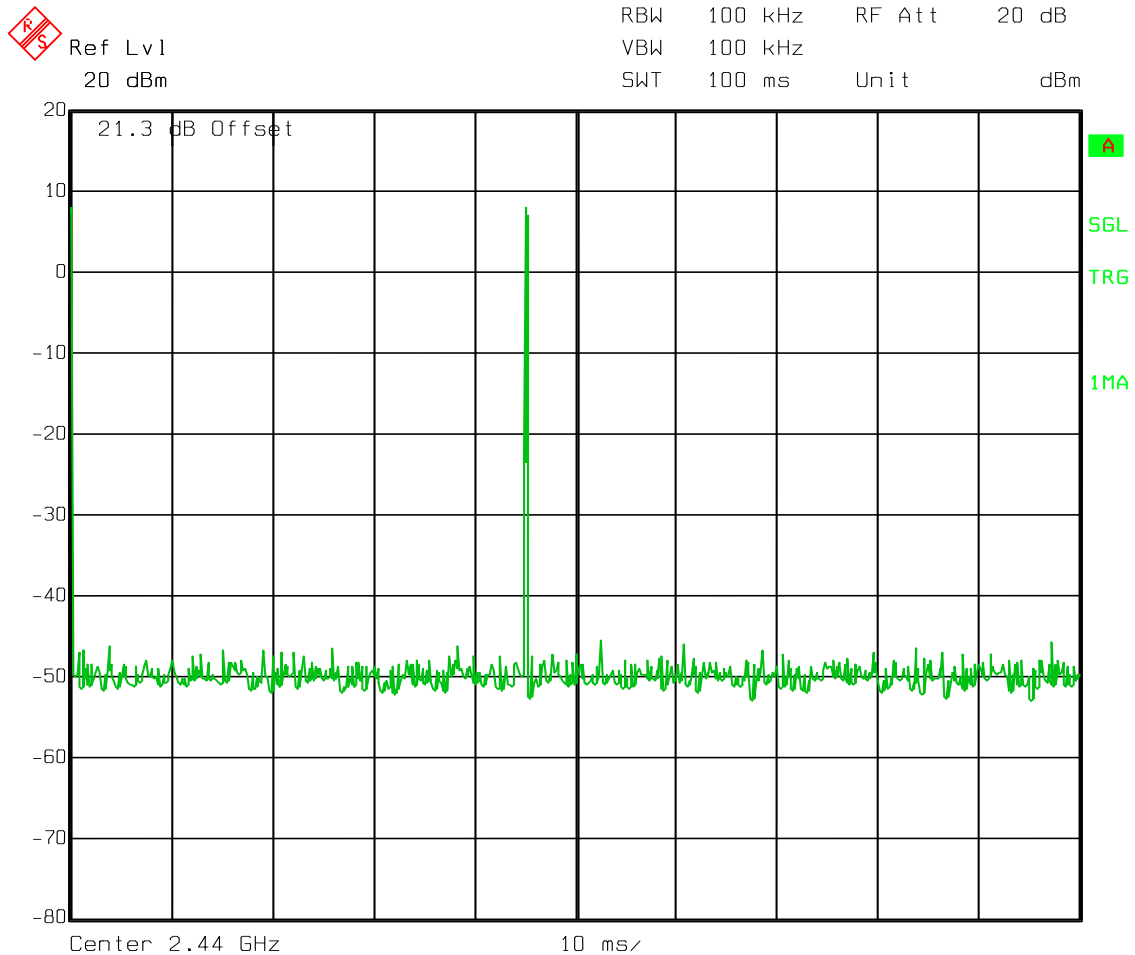

Date: 29.JAN.2013 11:37:43

$$20 \log (0.65/100) = -43.7 \text{ dB}$$

Test Data - Radiated Emissions

Duty Cycle Correction (Bluetooth Low Energy)

 Ref Lvl 20 dBm Delta 1 [T1] -1.50 dB RBW 1 MHz RF Att 30 dB
190.380762 μ s VBW 1 MHz Unit dBm
SWT 5 ms

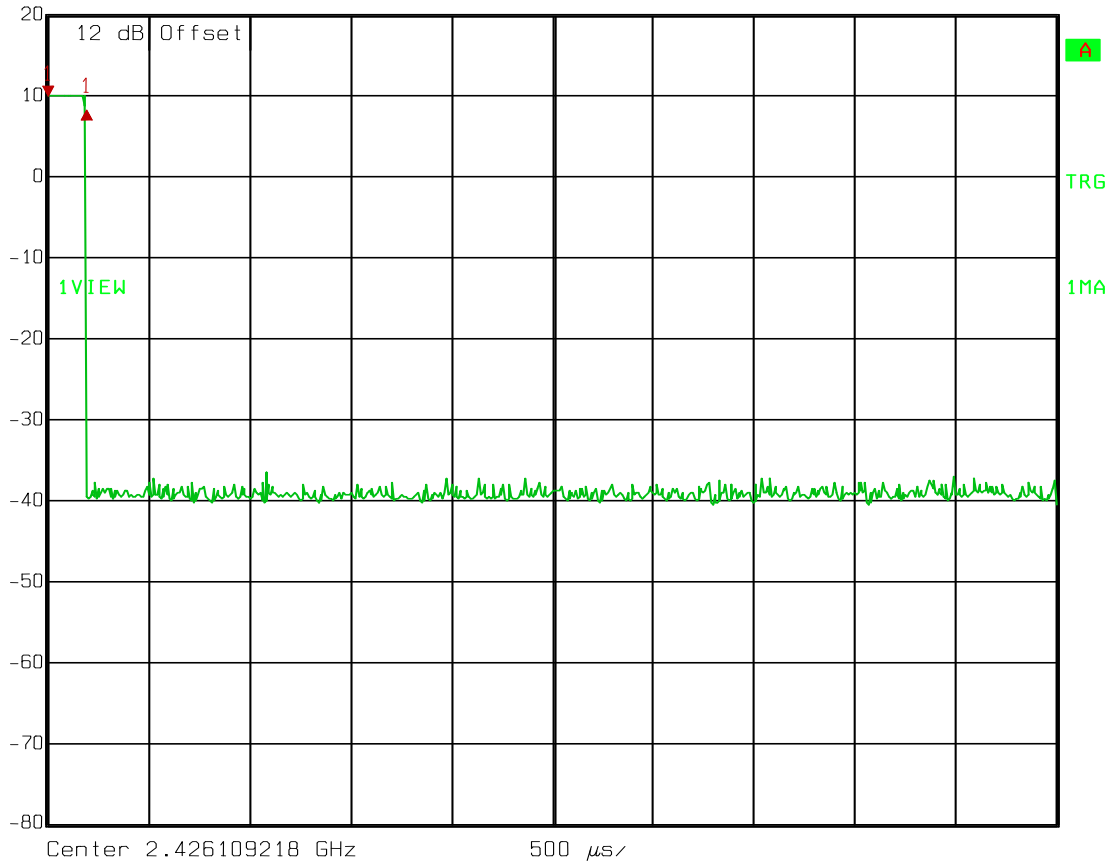

Date: 04.APR.2013 12:33:54

Test Data - Radiated Emissions

Duty Cycle Correction (Bluetooth Low Energy)



Ref Lvl 20 dBm
RBW 1 MHz RF Att 30 dB
VBW 1 MHz
SWT 100 ms Unit dBm

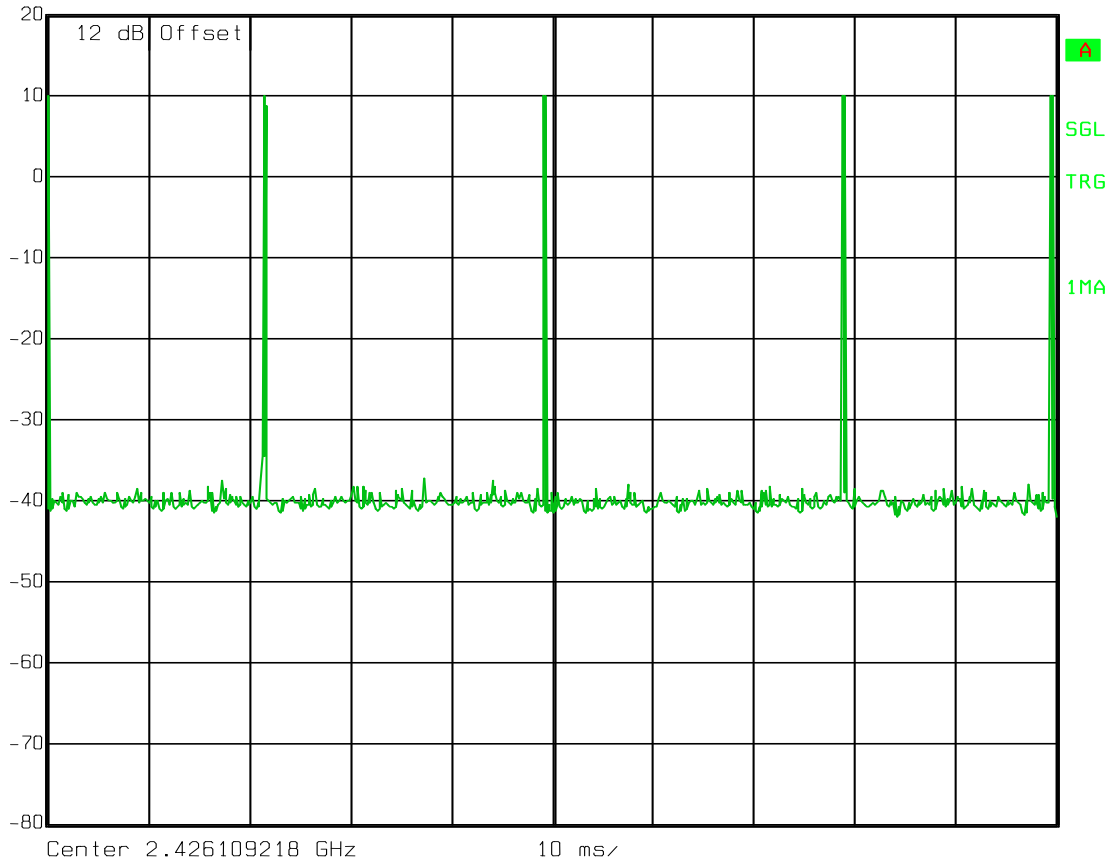

Date: 04.APR.2013 12:34:40

$$20 \log (0.95/100) = -40.4 \text{ dB}$$

Section 8. Powerline Conducted Emissions

NAME OF TEST: Powerline Conducted Emissions	PARA. NO.: 15.207(a) RSS-Gen 7.2.4
TESTED BY: David Light	DATE: 31 January 2013

Test Results: Complies. The worst case emission was 47.0 dB μ V at 18.0 MHz. This is 3 dB below the average specification limit of 50.0 dB μ V.

Test Data: Refer to attached plots

Equipment Used: 1950-674-1924-1188-1548-704

Measurement Uncertainty: +/- 1.7 dB

Temperature: 22 °C

Relative Humidity: 47 %

Test Data – Powerline Conducted Emissions

Line side

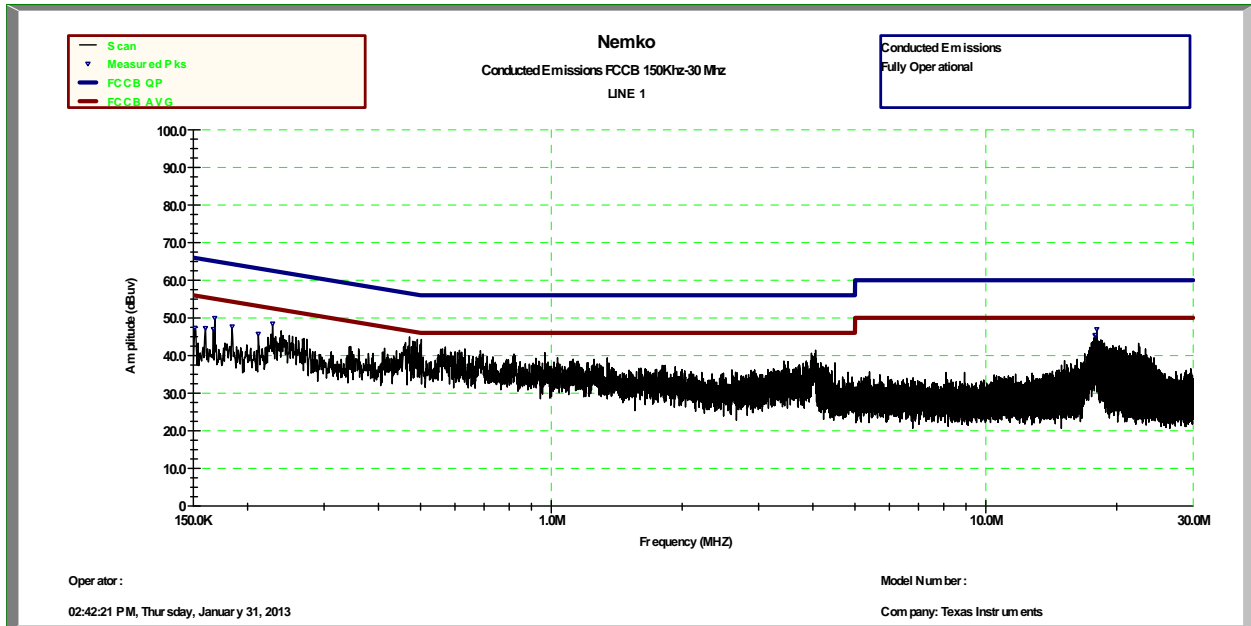

Neutral side

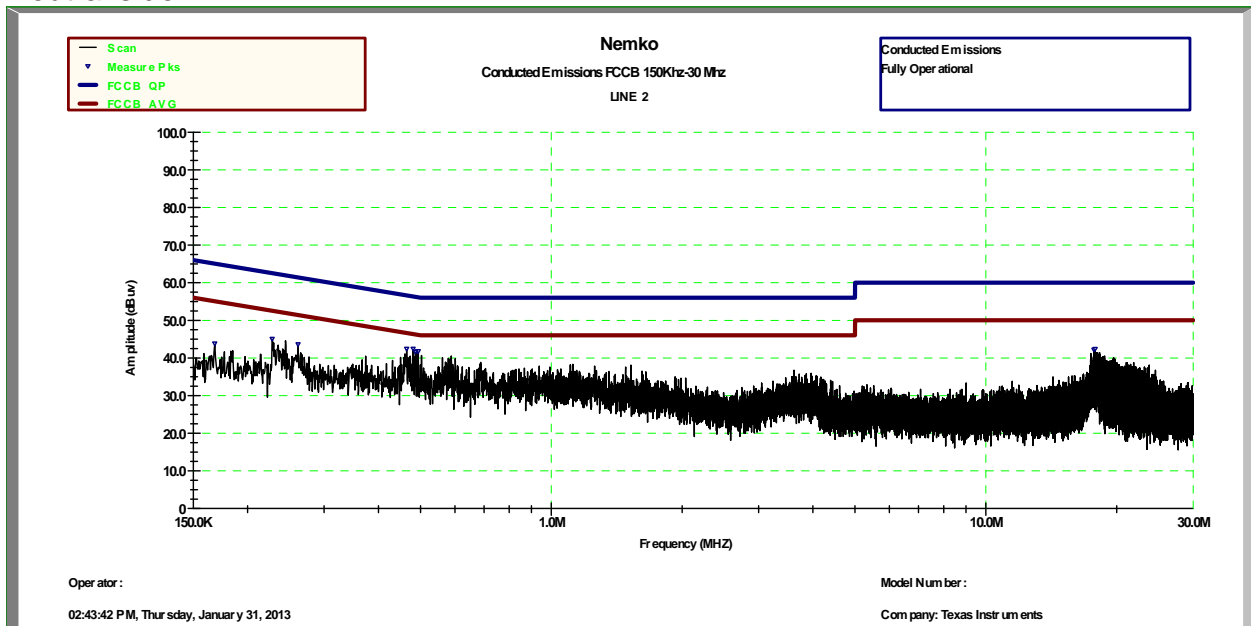

EQUIPMENT: CC256x QFN EM

PROJECT NO.:10238472RUS1

Section 9. Peak Power Spectral Density

NAME OF TEST: Peak Power Spectral Density	PARA. NO.: 15.247(e) A8.2(b)
TESTED BY: David Light	DATE: 29 January 2013

Test Results: Complies.

Measurement Data: See attached data..

Test Conditions: 22 %RH
47 °C

Measurement Uncertainty: +/-1.7 dB

Test Equipment Used: 1036-1082-1472

Peak Power Spectral Density

Density
Low Channel



Marker 1 [T1] RBW 100 kHz RF Att 20 dB
Ref Lvl 7.27 dBm VBW 300 kHz
20 dBm 2.40224349 GHz SWT 5 ms Unit dBm

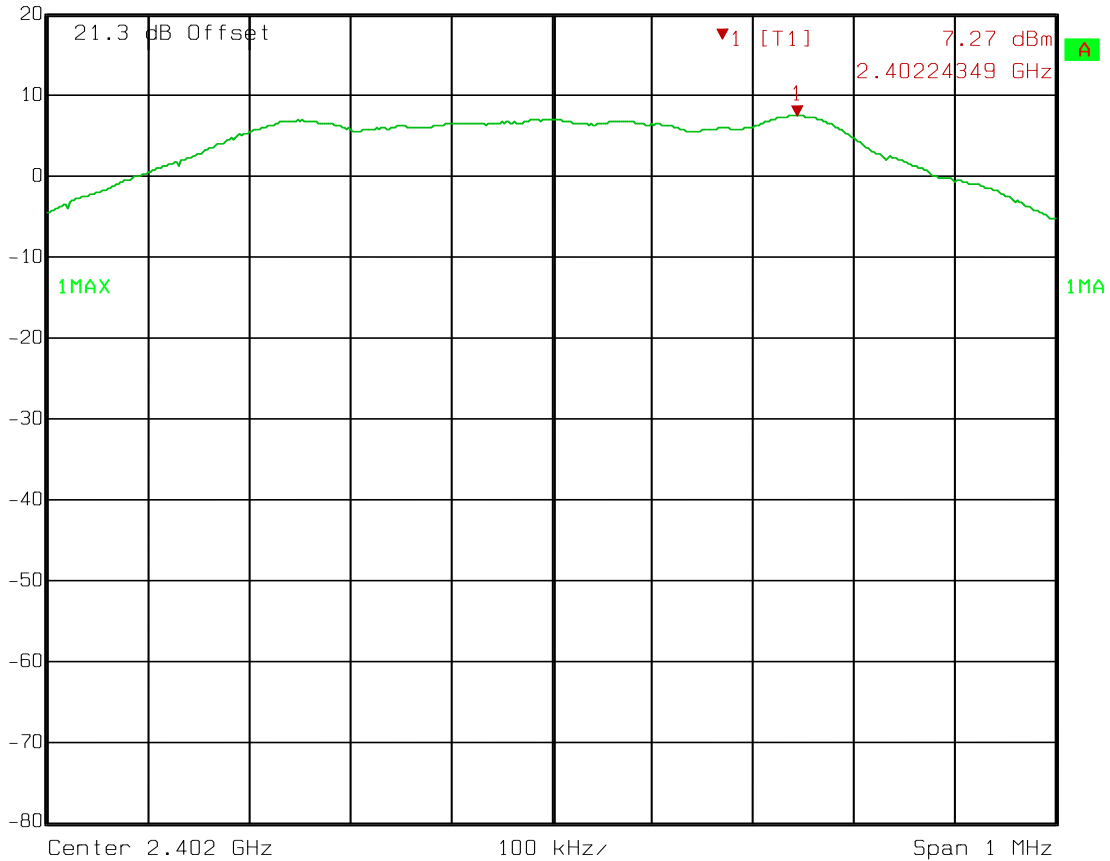

Date: 29.JAN.2013 12:10:03

Peak Power Spectral Density

Density
Mid Channel



Ref Lvl 20 dBm
Marker 1 [T1] 7.33 dBm
2.44223948 GHz
RBW 100 kHz RF Att 20 dB
VBW 300 kHz
SWT 5 ms Unit dBm

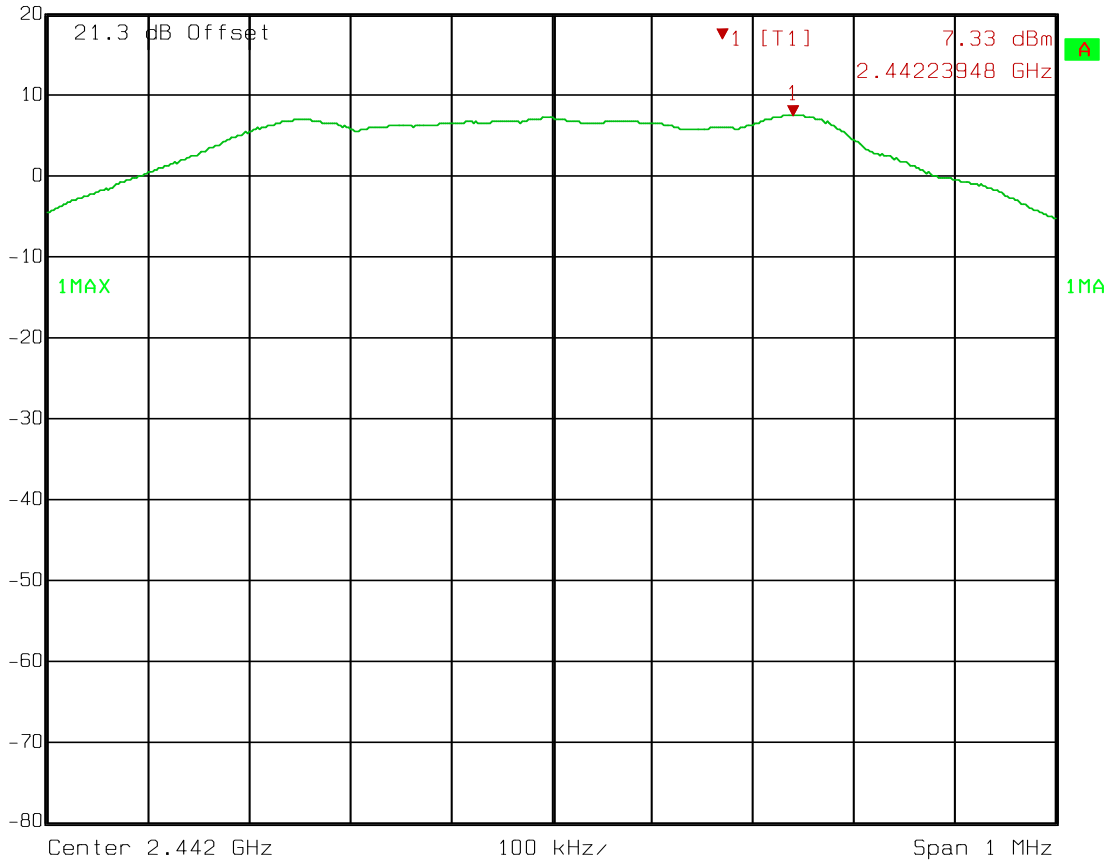

Date: 29.JAN.2013 12:09:29

Peak Power Spectral Density

Density
High Channel



Marker 1 [T1] RBW 100 kHz RF Att 20 dB
7.13 dBm VBW 300 kHz
20 dBm 2.47923948 GHz SWT 5 ms Unit dBm

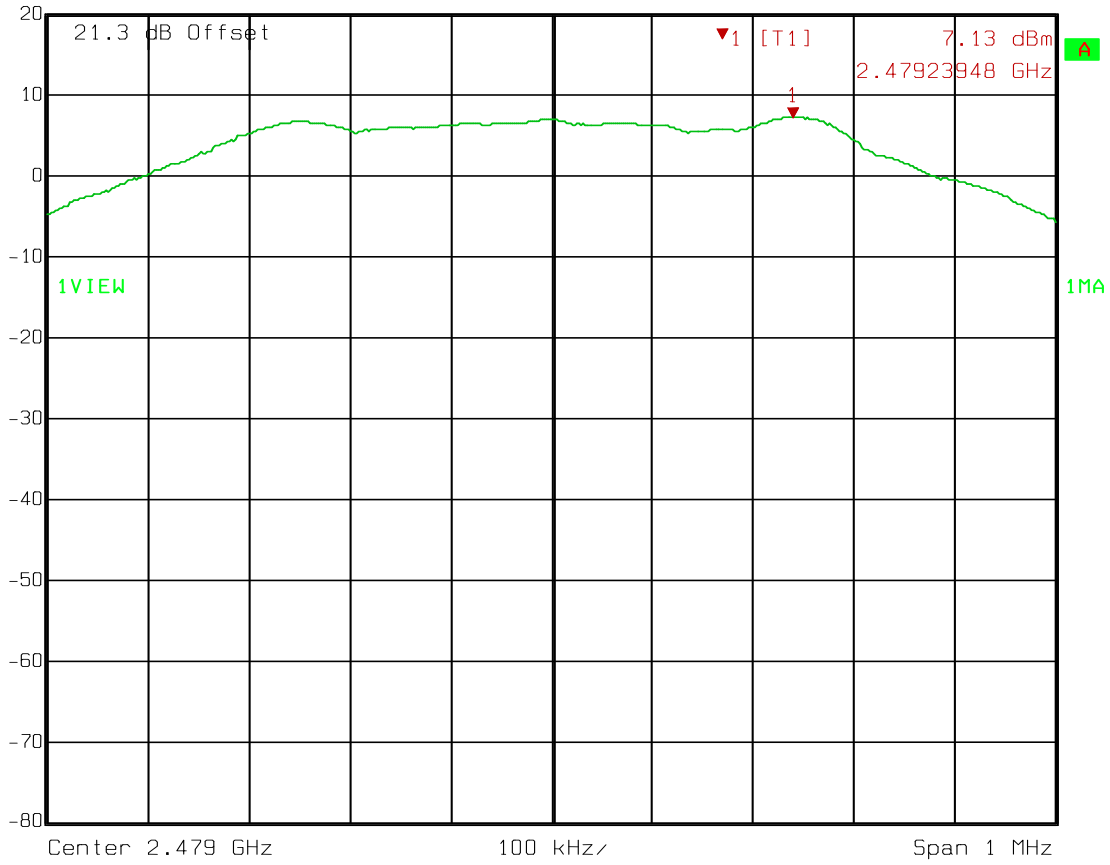

Date: 29.JAN.2013 12:08:53

EQUIPMENT: CC256x QFN EM

PROJECT NO.:10238472RUS1

Section 10. Occupied Bandwidth

NAME OF TEST: Occupied Bandwidth	PARA. NO.: 15.247(a)(2) A8.2
TESTED BY: David Light	DATE: 29 January 2013

Test Results: Complies.

Measurement Data: See 6 dB BW plot
Measured 6 dB bandwidth:

Test Conditions: 22 %RH
47 °C

Measurement Uncertainty: +/-1x10⁻⁷ ppm

Test Equipment Used: 1036-1082-1472

Test Data – Occupied Bandwidth

Occupied Bandwidth
Low Channel

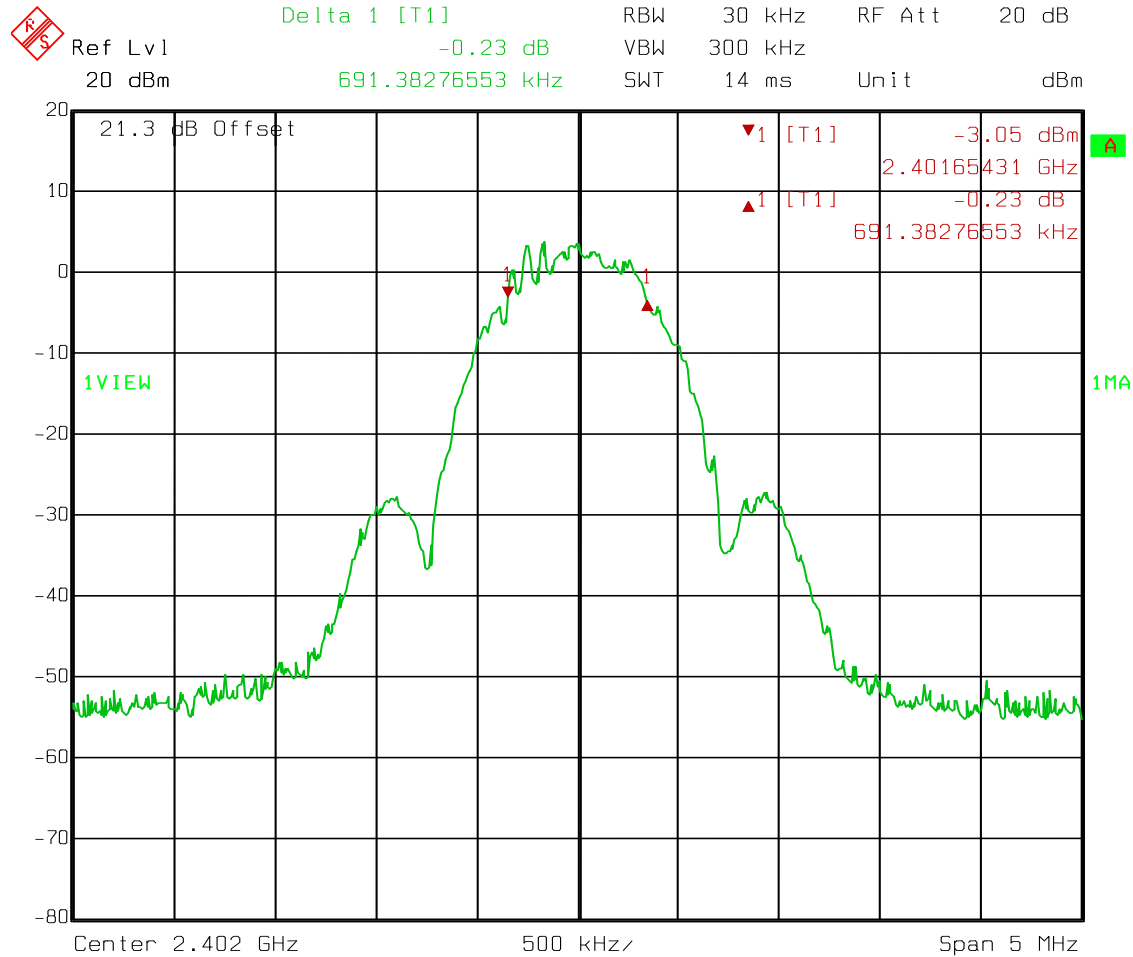

Date: 29.JAN.2013 12:02:40

Test Data – Occupied Bandwidth

Occupied Bandwidth
Mid Channel

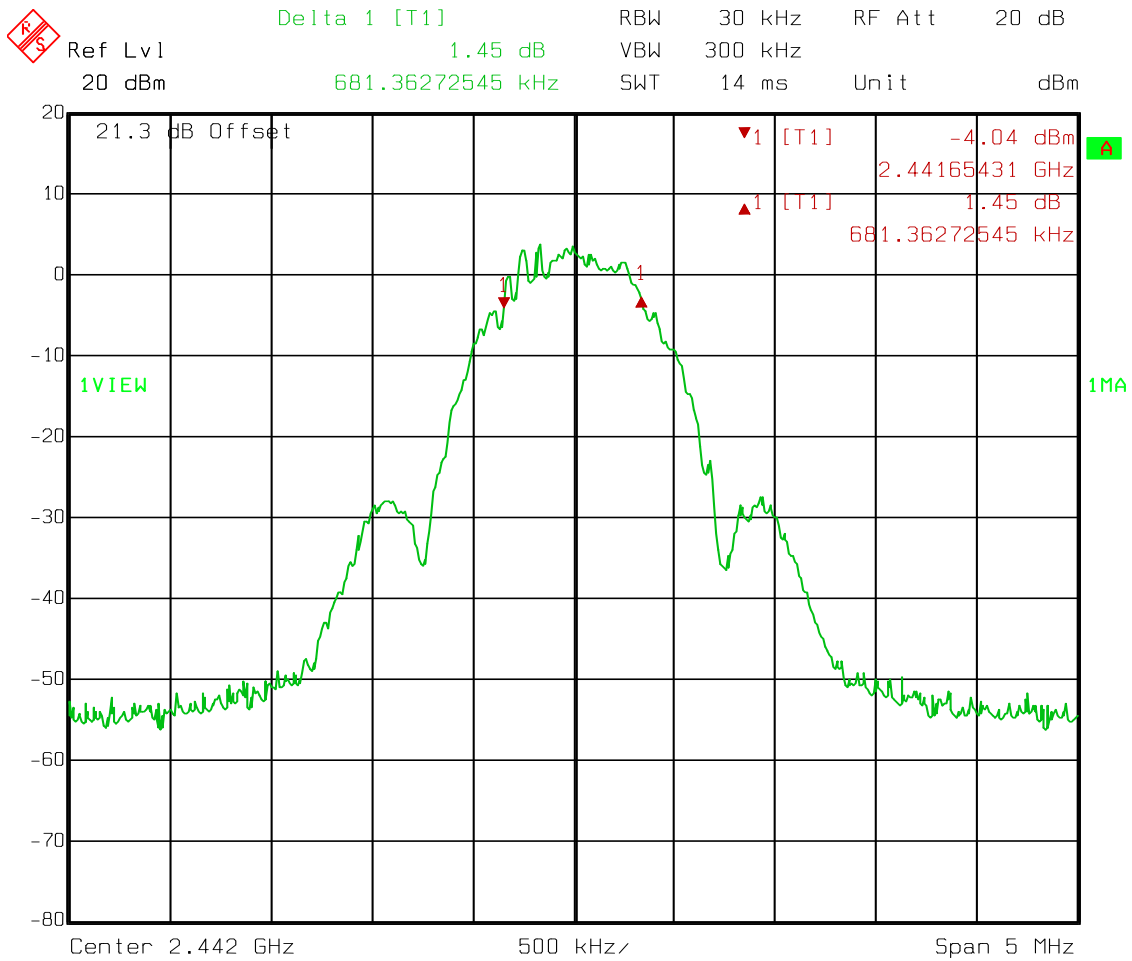

Date: 29.JAN.2013 12:05:39

Test Data – Occupied Bandwidth

Occupied Bandwidth
High Channel



Ref Lvl	Delta 1 [T1]	RBW	30 kHz	RF Att	20 dB
20 dBm	1.88 dB	VBW	300 kHz		
	731.46292585 kHz	SWT	14 ms	Unit	dBm

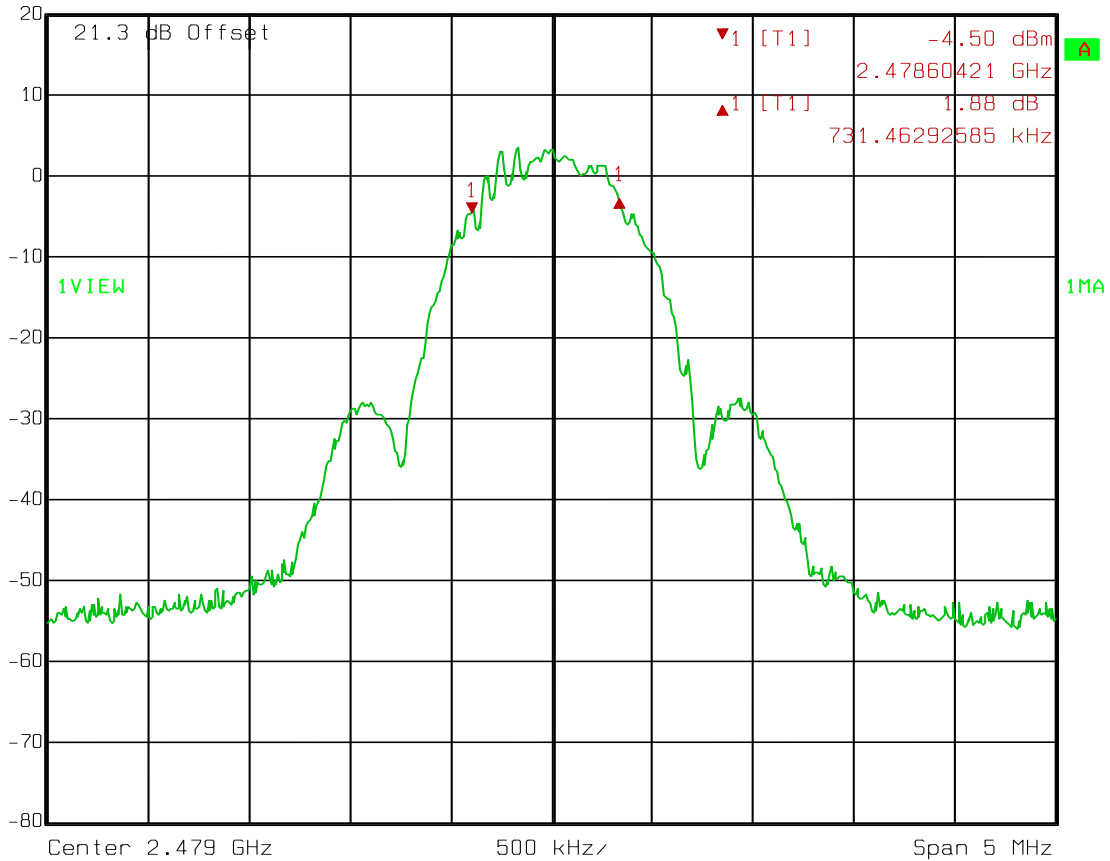

Date: 29.JAN.2013 12:06:43

Test Data – Occupied Bandwidth

99% Bandwidth

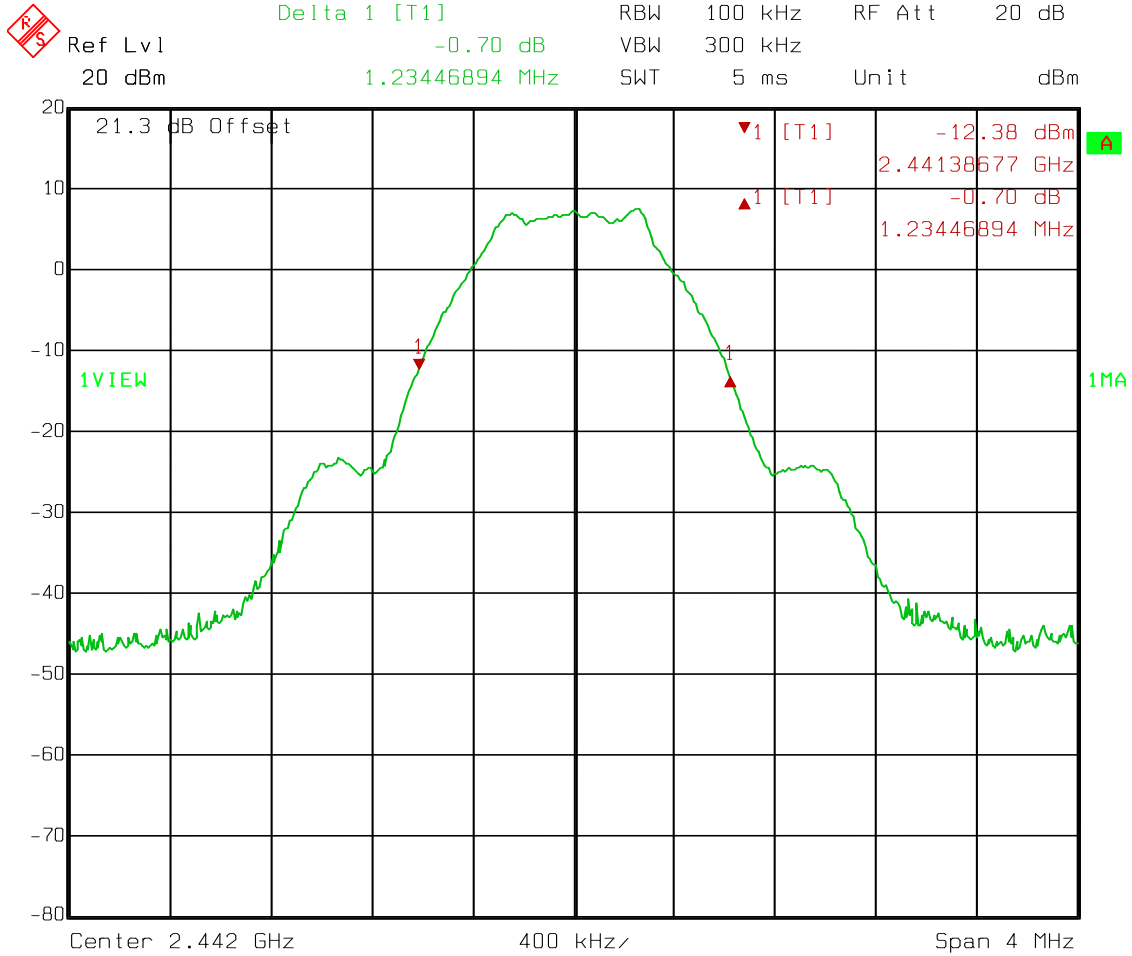

Date: 29.JAN.2013 12:11:27

EQUIPMENT: CC256x QFN EM

PROJECT NO.:10238472RUS1

Section 11. Test Equipment List

Asset Tag	Description	Manufacturer	Model	Serial #	Last Cal	Next Cal
674	Limiter	Hewlett Packard	11947A	3107A02200	02-Nov-2012	02-Nov-2013
704	Filter, High Pass, 5KHz	Solar Electronics	7930-5.0	933126	18-Jan-2013	18-Jan-2014
993	Antenna, Horn	A.H. Systems	SAS-200/571	162	22-Sep-2011	22-Sep-2013
1016	Preamplifier	Hewlett Packard	8449A	2749A00159	23-Jul-2012	23-Jul-2013
1036	Spectrum Analyzer	Rohde & Schwartz	FSEK30	830844/006	23-Dec-2011	23-Dec-2013
1082	Cable, 2m	Astrolab	32027-2-29094-72TC		N/R	
1188	LISN	EMCO	3825/2	1214	17-Oct-2012	17-Oct-2013
1472	Attenuator,	Omni Spectra	20600-20db		N/R	
1480	Antenna, Bilog	Schaffner-Chase	CBL6111C	2572	25-Feb-2013	25-Feb-2014
1783	Cable Assy, 3m Chamber	Nemko	Chamber		26-Sep-2012	26-Sep-2013
791	Pre Amplifier	Nemko, USA	CRA69 321003 9605	119	19-Oct-2012	19-Oct-2013
1548	0.5m Cable Assy	Nemko USA	RG213		13-Feb-2012	13-Feb-2013
1924	3m Cable	Nemko USA	1924 RG 214	1	21-Jan-2013	21-Jan-2014
1950	Spectrum Analyzer	Rohde & Schwartz	FSP	100037	17-Jan-2013	17-Jan-2014

ANNEX A - TEST DETAILS

NAME OF TEST: Powerline Conducted Emissions

PARA. NO.: 15.207(a)
RSS-Gen 7.2.4

Minimum Standard: Conducted limits.

(a) Except as shown in paragraphs (b) and (c) of this section, for an intentional radiator that is designed to be connected to the public utility (AC) power line, the radio frequency voltage that is conducted back onto the AC power line on any frequency or frequencies, within the band 150 kHz to 30 MHz, shall not exceed the limits in the following table, as measured using a 50 mH/50 ohms line impedance stabilization network (LISN). Compliance with the provisions of this paragraph shall be based on the measurement of the radio frequency voltage between each power line and ground at the power terminal. The lower limit applies at the boundary between the frequency ranges.

Frequency of Conducted Emission (MHz)	Limit (dBmV)	
	Quasi-peak	Average
0.15-0.5	66 to 56*	56 to 46*
0.5-5	56	46
5-30	60	50

* Decreases with the logarithm of the frequency.

(b) The limit shown in paragraph (a) of this section shall not apply to carrier current systems operating as intentional radiators on frequencies below 30 MHz. In lieu thereof, these carrier current systems shall be subject to the following standards:

(1) For carrier current systems containing their fundamental emission within the frequency band 535-1705 kHz and intended to be received using a standard AM broadcast receiver: no limit on conducted emissions.

(2) For all other carrier current systems: 1000 mV within the frequency band 535-1705 kHz, as measured using a 50 mH/50 ohms LISN.

(3) Carrier current systems operating below 30 MHz are also subject to the radiated emission limits as provided in §15.205 and §§15.209, 15.221, 15.223, 15.225 or 15.227, as appropriate.

(c) Measurements to demonstrate compliance with the conducted limits are not required for devices which only employ battery power for operation and which do not operate from the AC power lines or contain provisions for operation while connected to the AC power lines. Devices that include, or make provision for, the use of battery chargers which permit operating while charging, AC adaptors or battery eliminators or that connect to the AC power lines indirectly, obtaining their power through another device which is connected to the AC power lines, shall be tested to demonstrate compliance with the conducted limits.

EQUIPMENT: CC256x QFN EM

PROJECT NO.:10238472RUS1

NAME OF TEST: Channel Separation

PARA. NO.: 15.247(a)(1)/A8.1(b)

Minimum Standard:

Frequency hopping systems shall have hopping channel carrier frequencies separated by a minimum of 25 kHz or the 20 dB bandwidth of the hopping channel, whichever is greater. Alternatively, frequency hopping systems operating in the 2400-2483.5 MHz band may have hopping channel carrier frequencies that are separated by 25 kHz or two-thirds of the 20 dB bandwidth of the hopping channel, whichever is greater, provided the systems operate with an output power no greater than 125 mW.

NAME OF TEST: Time of Occupancy	PARA. NO.: 15.247(a)(1)/A8.1(d)
---------------------------------	---------------------------------

Minimum Standard:

Frequency Band (MHz)	20 dB Bandwidth	No. of Hopping Channels	Average Time of Occupancy
902 - 928	<250 kHz	50	=<0.4 sec. in 20 sec.
902 – 928	=>250 kHz	25	=<0.4 sec. in 10 sec.
2400 – 2483.5	-----	75	=<0.4 sec. in 0.4 seconds multiplied by the number of hopping channels employed.
5725 – 5850	-----	75	=<0.4 sec. in 30 sec.

Method Of Measurement:

The spectrum analyzer is set as follows:

- RBW: 1 MHz
- VBW: = RBW
- Span: 0 Hz
- LOG dB/div.: 10 dB
- Sweep: Sufficient to see one hop time sequence.
- Trigger: Video

The occupancy time of one hop is measured as above. The average time of occupancy is calculated over the appropriate period of time from above table

Avg. time of occupancy = (period from table/duration of one hop)/no. of channels multiplied by the duration of one hop.

For instance:

If a 2.4 GHz system has a measured hop duration time of 1 msec. and uses 75 channels, then the average time of occupancy would be:

$$(30 \text{ sec.}/.001 \text{ sec.})/75 \text{ chan.} = 400 \times 1 \text{ msec.} = 400 \text{ msec. or } 0.4 \text{ sec. in } 30 \text{ sec.}$$

EQUIPMENT: CC256x QFN EM

PROJECT NO.:10238472RUS1

NAME OF TEST: Occupied Bandwidth	PARA. NO.: 15.247(a)(1)/A8.2
----------------------------------	------------------------------

Minimum Standard:

Frequency Band (MHz)	Maximum 20 dB Bandwidth
902 - 928	500 kHz
2400 – 2483.5	Not defined
5725 – 5850	1 MHz

Method Of Measurement:

The spectrum analyzer is set as follows:

RBW: At least 1% of span/div.

VBW: >RBW

Span: Sufficient to display 20 dB bandwidth

LOG dB/div.: 10 dB

Sweep: Auto

Number of channels tested:

Tuning range	Number of channels tested	Channel location in band
1 MHz or less	1	middle
1 to 10 MHz	2	top and bottom
more than 10 MHz	3	top, middle, bottom

NAME OF TEST: Peak Power Output	PARA. NO.: 15.247(b)/A8.4
---------------------------------	---------------------------

Minimum Standard:

Frequency Band (MHz)	No. of Hopping Channels	Maximum Peak Power Output at Antenna Port
902 - 928	at least 50	1 watt
902 – 928	25 - 49	0.25 watts
2400 – 2483.5	75	1 watt
5725 – 5850	75	1 watt

If transmitting antennas of directional gain greater than 6 dBi are used, the power shall be reduced by the amount in dB that the directional gain of the antenna exceeds 6 dBi.

Systems operating in the 2400-2483.5 MHz band that are used exclusively for fixed, point to point operation may employ transmitting antennas with directional gain greater than 6 dBi provided the maximum peak output power is reduced by 1 dB for every 3 dB that the directional gain of the antenna exceed 6 dBi.

Systems operating in the 5725 – 5850 MHz band that are used exclusively for fixed, point-to-point operation may employ transmitting antennas with directional gain greater than 6 dBi without any corresponding reduction in transmitter peak output power.

Direct Measurement Method For Detachable Antennas:

If the antenna is detachable, a peak power meter is used to measure the power output with the transmitter operating into a 50 ohm load. The dBi gain of the antenna(s) employed shall be reported.

Calculation Of EIRP For Integral Antenna:

If the antenna is not detachable from the circuit then the Peak Power Output is derived from the peak radiated field strength of the fundamental emission by using the plane wave relation $GP/4\pi R^2 = E^2/120\pi$ and proceeding as follows:

$$P = \frac{E^2 R^2}{30G} = \frac{E^2 3^2}{30G}$$

where,

P = the equivalent isotropic radiated power in watts

E = the maximum measured field strength in V/m

R = the measurement range (3 meters)

G = the numeric gain of the transmit antenna in relation to an isotropic radiator

The RBW of the spectrum analyzer shall be set to a value greater than the measured 20 dB occupied bandwidth of the E.U.T.

Number of channels tested:

Tuning range	Number of channels tested	Channel location in band
1 MHz or less	1	middle
1 to 10 MHz	2	top and bottom
more than 10 MHz	3	top, middle, bottom

NAME OF TEST: Spurious Emissions at Antenna	PARA. NO.: 15.247(d)/A8.5
--	----------------------------------

Minimum Standard: In any 100kHz bandwidth outside the frequency band in which the transmitter is operating, emissions shall be at least 20 dB below the fundamental emission or shall not exceed the following field strength limits. Emissions falling in the restricted bands of 15.205 shall not exceed the following field strength limits:

Frequency (MHz)	Field Strength ($\mu\text{V/m}$ @ 3m)	Field Strength (dB @ 3m)
30 - 88	100	40.0
88 - 216	150	43.5
216 - 960	200	46.0
Above 960	500	54.0

THE SPECTRUM WAS SEARCHED TO THE 10th HARMONIC

Method Of Measurement:

30 MHz - 10th harmonic plot
 RBW: 100 kHz
 VBW: 300 kHz
 Sweep: Auto
 Display line: -20 dBc

Lower Band Edge

RBW: At least 1% of span/div.
 VBW: >RBW
 Span: As necessary to display any spurious at band edge.
 Sweep: Auto
 Center Frequency: 902 MHz, 2400 MHz, or 5725 MHz
 Marker: Peak of fundamental emission
 Marker Δ : Peak of highest spurious level below center frequency.

Upper Band Edge

RBW: At least 1% of span/div.
 VBW: >RBW
 Span: As necessary to display any spurious at band edge.
 Sweep: Auto
 Center Frequency: 928 MHz, 2483.5 MHz, or 5850 MHz
 Marker: Peak of fundamental emission
 Marker Δ : Peak of highest spurious level above center frequency.

Number of channels tested:

Tuning range	Number of channels tested	Channel location in band
1 MHz or less	1	middle
1 to 10 MHz	2	top and bottom
more than 10 MHz	3	top, middle, bottom

EQUIPMENT: CC256x QFN EM

PROJECT NO.:10238472RUS1

NAME OF TEST: Radiated Emissions	PARA. NO.: 15.247(d)/RSS-Gen 7.2.2
----------------------------------	------------------------------------

Minimum Standard: In any 100kHz bandwidth outside the frequency band in which the transmitter is operating, emissions shall be at least 20 dB below the fundamental emission or shall not exceed the following field strength limits:

Emissions falling in the restricted bands of 15.205 shall not exceed the following field strength limits:

Frequency (MHz)	Field Strength (µV/m @ 3m)	Field Strength (dB @ 3m)
30 - 88	100	40.0
88 - 216	150	43.5
216 - 960	200	46.0
Above 960	500	54.0

THE SPECTRUM WAS SEARCHED TO THE 10th HARMONIC

15.205 Restricted Bands

MHz	MHz	MHz	GHz
0.09-0.11	16.42-16.423	399.9-410	4.5-5.25
0.495-0.505	16.69475-16.69525	608-614	5.35-5.46
2.1735-2.1905	16.80425-16.80475	960-1240	7.25-7.75
4.125-4.128	25.5-25.67	1300-1427	8.025-8.5
4.17725-4.17775	37.5-38.25	1435-1626.5	9.0-9.2
4.20725-4.20775	73-74.6	1645.5-1646.5	9.3-9.5
6.125-6.218	74.8-75.2	1660-1710	10.6-12.7
6.26775-6.26825	108-121.94	1718.8-1722.2	13.25-13.4
6.31175-6.31225	123-138	2200-2300	14.47-14.5
8.291-8.294	149.9-150.05	2310-2390	15.35-16.2
8.362-8.366	156.52475-156.52525	2483.5-2500	17.7-21.4
8.37625-8.38675	156.7-156.9	2655-2900	22.01-23.12
8.41425-8.41475	162.0125-167.17	3260-3267	23.6-24.0
12.29-12.293	167.72-173.2	3332-3339	31.2-31.8
12.51975-12.52025	240-285	3345.8-3358	36.43-36.5
12.57675-12.57725	322-335.4	3600-4400	Above 38.6
13.36-13.41	1718		

Number of channels tested:

Tuning range	Number of channels tested	Channel location in band
1 MHz or less	1	middle
1 to 10 MHz	2	top and bottom
more than 10 MHz	3	top, middle, bottom

ANNEX B - TEST DIAGRAMS

Test Site For Radiated Emissions

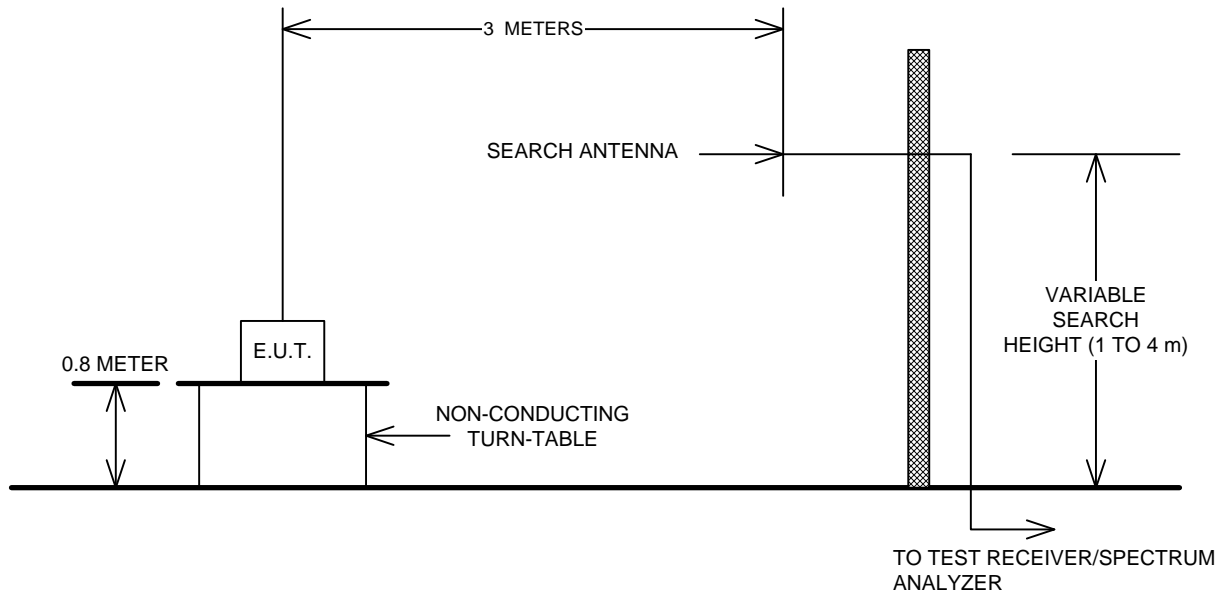

Conducted Emissions

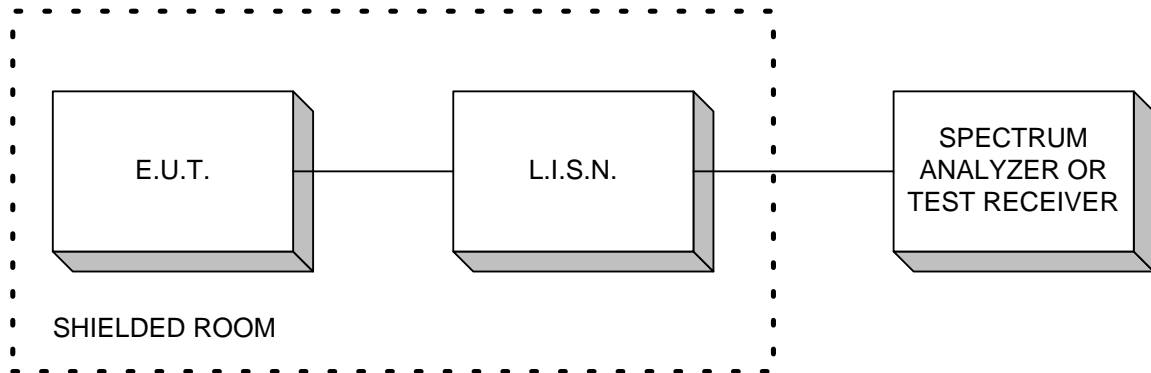

Peak Power at Antenna Terminals

