



深圳市华利进电子有限公司

承认书

客 户: 东莞市永福电子有限公司

客户料号: 160-15010000-0020

物料名称: _____

品 名: HLJ1812-150M

版 本: A

日 期: 2016-8-8



出 图		
制图	审核	批准
		<i>[Signature]</i> 2016-8-8

客 户 承 认
<i>[Signature]</i> 2016-8-8
请于承认后签章返回

地址: 深圳市光明新区公明楼村第二工业区中泰街六栋

电话: 0755-83956780

传真: 0755-83956781

Http://www.szhlxdz.com

E-mail:hlx_8@163.com

深圳市华利进电子有限公司

规格书

SPECIFICATION FOR APPROVAL



SPECIFICATION FOR	DATE: 2016-8-8
P/N: HLJ1812-150M	ISSUE NO: EG16080801

1. DIMENSION (UNIT:mm)

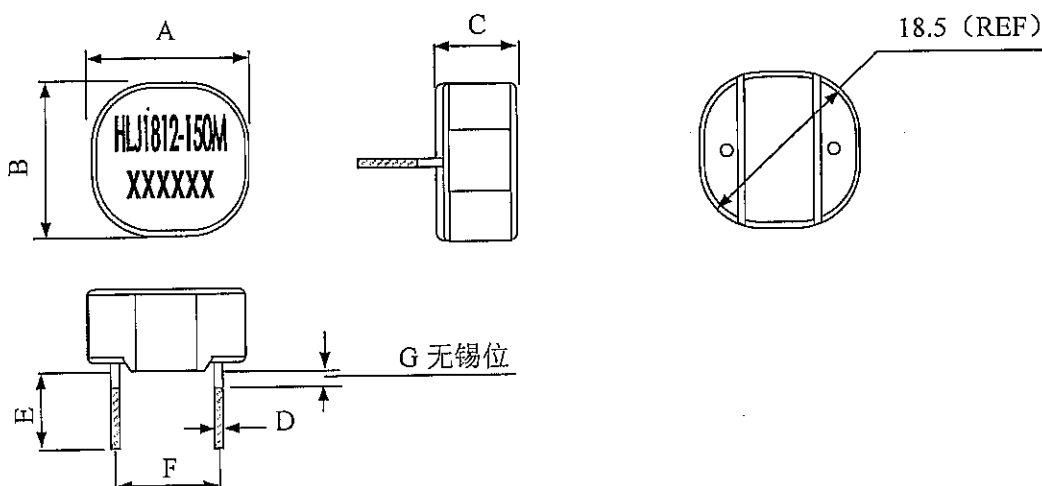

A: 17.8 (Max)	B: 17.8 (Max)	C: 12 (Max)	D: 1.2 ± 0.1
E: 3.4 ± 0.5 (不含锡尖)	F: 13 ± 0.5	G: 1.0 (Max)	

2. ELECTRICAL REQUIREMENTS

TEST CONDITION		TEST FREQ/V	TEST INSTRUMENTS	
L	15μH±20%	100KHz/1V	LCR-METER	CH-1062/VR115
Q	25 Min	100KHz/1V	LCR-METER	CH-1062/VR115
DCR	10mΩ (Max)		DCR-METER	VR131
I _{rms}	13Amp	100KHz/1V	DC POWER SUPPLY	DH1716-2D
I _{sat}	15Amp	100KHz/1V	CURRENT SOURCE	VR7210+VR116
TEMP	-25~125°C			

3. MATERIALS

CORE:	铁粉芯	
WIRE:	Φ 1.2mm	鑫新股份上饶线材厂
PACKING:	吸塑盘	100PCS/盘, 800PCS/箱

4. NOTE: 储存条件: 温度 25~35°C; 相对湿度 45~80%RH;

SGS No.CANEC1002660804

5. APPROVED BY CUSTOMER:	DRAWN BY	CHECKED BY	APPROVED BY
	刁伟涛	张良	赖富忠

EG: 01

REV: 00

深圳市华利进电子有限公司

检验记录表

品名	HLJ1812-150M			订单号码						
图号	EG16080801			检验日期	2016-8-8					
批量				抽样依据	MIL-STD-105E 质量水平: II					
测试仪器	LCR:CH-1062/VR116 DC Sourec:VR7210 DCR:VR131			测试条件	100kHz/1V					
检验内容	电参数			外形尺寸						
检验项目	L (μH)			DCR (mΩ)	A (mm)	B (mm)	C (mm)	D (mm)	E (mm)	F (mm)
	0A	15A								
要求	15±20%	80%L (0) TYP		10Max	17.8Max	17.8Max	12Max	1.2±0.1	3.4±0.5	13±0.5
1	14.39	11.77	81.8%	8.48	17.38	17.47	11.35	1.18	3.56	13.17
2	15.46	12.69	82.1%	8.46	17.59	17.5	11.49	1.17	3.48	13.19
3	13.67	11.26	82.4%	8.53	17.37	17.49	11.46	1.19	3.62	13.16
4	16.34	13.36	81.8%	8.51	17.48	17.42	11.38	1.19	3.55	13.20
5	15.41	12.55	81.5%	8.49	17.45	17.36	11.47	1.17	3.54	13.23
6	13.59	11.18	82.3%	8.46	17.41	17.46	11.41	1.18	3.47	13.18
7	14.37	11.74	81.7%	8.47	17.36	17.42	11.37	1.18	3.63	13.21
8	15.62	12.79	81.9%	8.53	17.39	17.43	11.34	1.18	3.58	13.19
9	14.40	11.67	81.1%	8.51	17.51	17.48	11.35	1.17	3.51	13.2
10	13.51	11.03	81.7%	8.47	17.36	17.46	11.42	1.19	3.64	13.22
\bar{X}										
R										
					决议:				QA:	
									崔红梅	
									主管:	
									刘标城	
批准:		赖富忠								
日期:		2016-7-1								

QC.01

REV:00

深圳市华利进电子有限公司

检验记录

品名	HLJ1812-150M	订单号码	
图号	EG16080801	检验日期	2016-8-8
批量		抽样依据	MIL-STD-105E 质量水平: II
测试仪器	LCR: VR116 DC Current Sourec: VR7210 DC Power supply: DC 1716-2D	测试条件	100kHz/1V

CURRENT VS INDUCTANCE

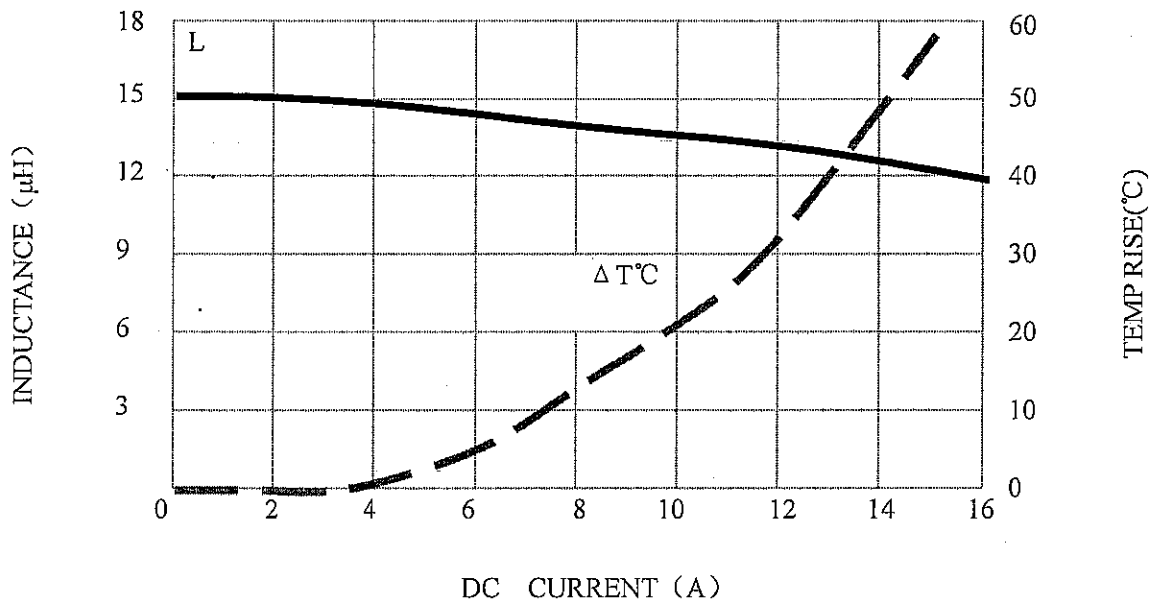

备注:

检测:	审核:	复核:
崔红梅	张良	赖富忠

深圳市华利进电子有限公司

(仅供参考)

1. 波峰焊接 曲线要求

