

60 dB Wide Dynamic Range, Low Frequency AGC Circuit Using a Single VGA

by James Staley

INTRODUCTION

Low frequency automatic gain control (AGC) circuits are used in audio and power equipment for applications such as sensitive microphone preamplifiers (preamps) and regulators. An AGC circuit, a closed-loop feedback system, is shown in Figure 1. The loop consists of a controllable gain element, a detector, a stable reference and a comparison circuit.

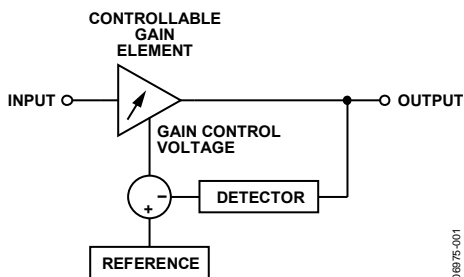

Figure 1. AGC Circuit Using a Variable Gain Amplifier

This application note describes a low frequency AGC circuit using a wide dynamic range AD8336 variable gain amplifier (VGA) as the gain control element, an AD736 rms-to-dc converter as the detector, a low cost rail-to-rail AD8551 op amp, and an ADP3339 LDO as the reference. Because of its wide controllable gain range and circuit flexibility, the AD8336 is featured in this application note.

Controllable Gain Element

A VGA is a special type of amplifier, which controls its gain by electronic means instead of by a set of fixed resistors, as is the case with the classic op amp circuit. VGAs are the familiar and preferred solution for automatic gain control circuits in a variety of communications applications.

VGAs operate at frequencies from hundreds of kilohertz up to hundreds of megahertz. An ideal VGA performs as a linear amplifier, without introducing distortion or otherwise corrupting the desired signal.

When a VGA is used, the gain element is an amplifier combined with electronic volume control. In this example, the controllable gain element is further reduced to an electronic potentiometer and a fixed gain amplifier and it adjusts the loop gain by attenuating the input signal, without contributing significant distortion. The other fundamental elements of the loop are the detector, a stable reference, and a summing circuit that senses the state of the loop, compares it to the stable reference, and adjusts the output accordingly.

A functional block diagram of the AD8336 is shown in Figure 2.

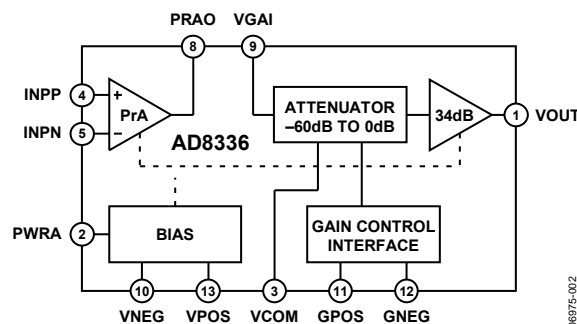

Figure 2. AD8336 Functional Block Diagram

TABLE OF CONTENTS

Introduction	1	AGC Circuit Design Example.....	3
Circuit Design	3	AGC Circuit Operation	4

CIRCUIT DESIGN

An audio AGC requires the following features:

- Wide dynamic range, which is the ability to amplify very low level signals and very large signals.
- Amplification with low distortion over the entire operating range.
- A means of adjusting the minimum and maximum gain limits.

The AD8336 described in this application note uses the Analog Devices, Inc. exclusive X-AMP® architecture, consisting of a ladder network with multiple taps spaced in equi-resistive increments, and accessed by an array of differential amplifiers. See Figure 3.

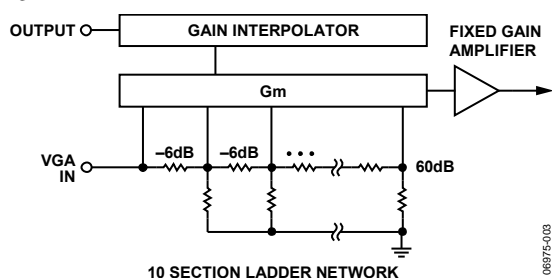

Figure 3. AD8336 Ladder Network

This circuit architecture offers several important advantages:

- A passive resistor ladder network performs the gain control function, introducing no distortion.
- The gain element is a fixed gain op amp. Because the gain of the op amp remains unchanged, the application benefits from constant bandwidth, distortion, and overload performance optimized over a wide range of operating conditions.

The AD8336 features a wide gain range (60 dB) and extended supply voltage, capable of operating with power supplies up to ± 15 V. It features an uncommitted preamplifier and permits inverting, noninverting, or differential input configurations.

The preamplifier and VGA sections are completely independent, and the VGA can be used as a standalone element if no preamp is needed. The gain control inputs are fully differential. Figure 4 shows the gain characteristic for the VGA, for two values of preamplifier gain.

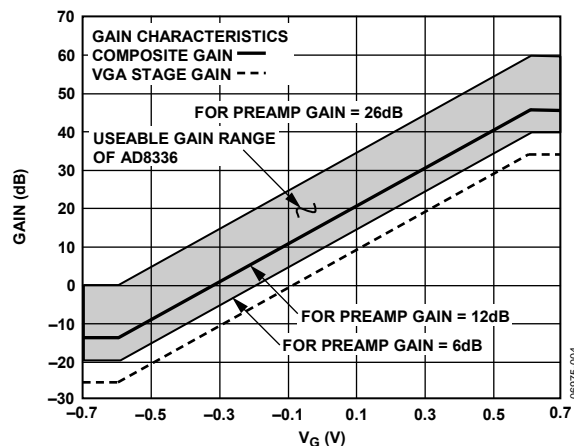

Figure 4. Gain Characteristics of the AD8336 for Various Operating Conditions

AGC CIRCUIT DESIGN EXAMPLE

Signal Voltage levels

The range of signal voltages to be controlled, the supply voltages and input and output voltage levels, all highly interactive factors, influence the topology of an AGC circuit. In this example, the goal is to fully exploit the full 60 dB gain control range of the AD8336. First, assume power supply voltages of ± 5 V.

With a known power supply voltage, the stabilized output voltage is established. Because saturation in either the preamplifier or the 34 dB fixed gain stage limits the available output swing to about 7 V p-p, a nominal maximum swing of 5 V p-p is easily attainable. With a preamp output-voltage swing of 5 V p-p and the X-AMP attenuator set for -26 dB ($0.05\times$), the output voltage is 250 mV p-p. If the preamp gain is set at $-1\times$ (unity inverting gain (equivalent to a noise gain of $2\times$), the maximum input voltage is 5 V p-p. Finally, with a gain range of 60 dB, the minimum input voltage is 5 mV p-p. The AGC circuit operates with an input voltage range of 60 dB (5 mV p-p to 5 V p-p), with a fixed output voltage of 250 mV p-p.

Control Voltage Levels

The differential gain control input of the AD8336 performs any level shifting required for the available control voltages considerably simplifying the gain control drive circuitry. In this example, the GNEG input (Pin 12) is biased at 0.75 V and the gain range voltage at GPOS is 1.5 V.

Detector

The detector is an AD736 rms-to-dc converter and provides an accurate dc control voltage directly proportional to the rms value of the output signal. The output of the AD736 drives the inverting input of an op amp connected for very high dc gain for accurate loop control.

AN-934

Comparison Circuit

The AD8551 is a single-supply rail-to-rail op amp with a very low offset voltage. The voltage applied to the noninverting input is the reference voltage, and establishes the rms value of the output. The voltage to be compared is the detector voltage from the rms-to-dc converter. When the comparison input falls below the reference the comparison output voltages increases to restore the output to its nominal level.

AGC CIRCUIT OPERATION

Table 1 lists the data for the AGC control for six frequencies from 1 mV to 2 V rms input. Refer to Figure 6 for a plot showing the flat output level vs. input for the typical audio frequency range of 20 Hz to 20 kHz. The output level is flat over the 2 mV rms to 2 V rms range.

Table 1.

EIN (V rms)	EOUT (mV p-p)					
	20 Hz	100 Hz	1 kHz	5 kHz	10 kHz	20 kHz
0.001	125	130	136	135	140	140
0.002	245	255	253	253	260	265
0.003	251	250	251	253	257	258
0.005	250	250	250	251	256	258
0.01	250	250	250	251	255	255
0.1	250	250	250	251	254	254
1	250	250	250	251	254	254
1.5	250	250	250	251	254	254
1.8	250	249	250	250	254	254
2	250	256	261	266	266	266

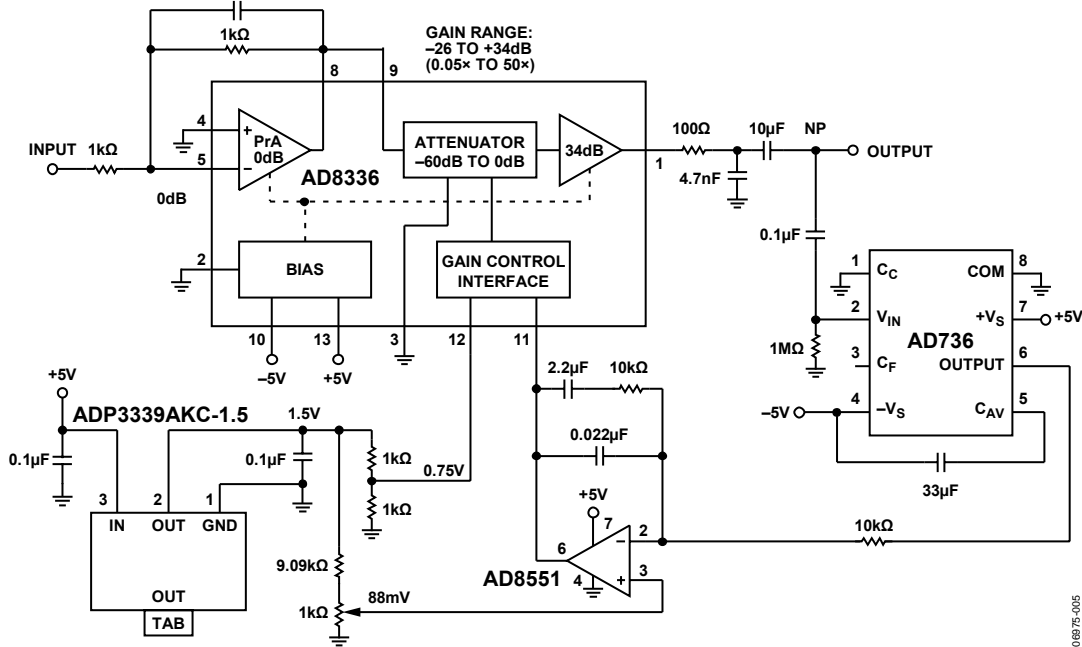

Figure 5. AGC Circuit Using the AD8336

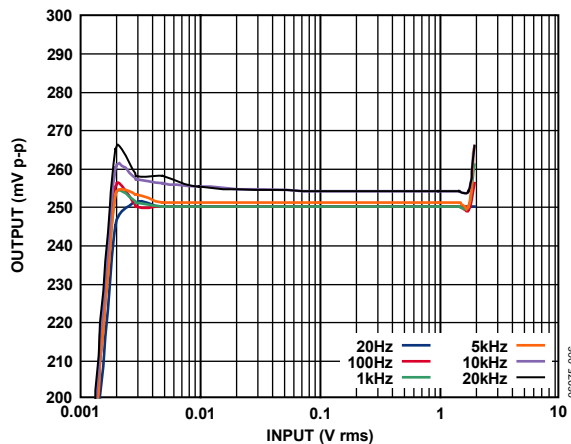

Figure 6. AGC Performance at Various Frequencies