



ATS2825 Bluetooth Module SPEC

Latest Version: 1.1

2015-10-26

Declaration

Disclaimer

Information given in this document is provided just as a reference or example for the purpose of using Actions' products, and cannot be treated as a part of any quotation or contract for sale.

Actions products may contain design defects or errors known as anomalies or errata which may cause the products' functions to deviate from published specifications. Designers must not rely on the instructions of Actions' products marked "reserved" or "undefined". Actions reserves these for future definition and shall have no responsibility whatsoever for conflicts or incompatibilities arising from future changes to them.

ACTIONS DISCLAIMS AND EXCLUDES ANY AND ALL WARRANTIES, INCLUDING WITHOUT LIMITATION ANY AND ALL EXPRESS OR IMPLIED WARRANTIES OF MERCHANTABILITY, ACCURACY, SECURITY, FITNESS FOR A PARTICULAR PURPOSE, TITLE, AND AGAINST INFRINGEMENT OF INTELLECTUAL PROPERTY AND THE LIKE TO THE INFORMATION OF THIS DOCUMENT AND ACTIONS PRODUCTS.

IN NO EVENT SHALL ACTIONS BE LIABLE FOR ANY DIRECT, INCIDENTAL, INDIRECT, SPECIAL, PUNITIVE, OR CONSEQUENTIAL DAMAGES WHATSOEVER, INCLUDING WITHOUT LIMITATION FOR LOSS OF DATA, PROFITS, SAVINGS OR REVENUES OF ANY KIND ARISING FROM USING THE INFORMATION OF THIS DOCUMENT AND ACTIONS PRODUCTS, REGARDLESS OF THE FORM OF ACTION, WHETHER BASED ON CONTRACT; TORT; NEGLIGENCE OF ACTIONS OR OTHERS; STRICT LIABILITY; OR OTHERWISE; WHETHER OR NOT ANY REMEDY OF BUYER IS HELD TO HAVE FAILED OF ITS ESSENTIAL PURPOSE, AND WHETHER ACTIONS HAS BEEN ADVISED OF THE POSSIBILITY OF SUCH DAMAGES OR NOT.

Actions' products are not designed, intended, authorized or warranted for use in any life support or other application where product failure could cause or contribute to personal injury or severe property damage. Any and all such uses without prior written approval of an Officer of Actions and further testing and/or modification will be fully at the risk of the customer.

Ways of obtaining information

Copies of this document and/or other Actions product literature, as well as the Terms and Conditions of Sale Agreement, may be obtained by visiting Actions' website at: <http://www.actions-semi.com> or from an authorized Actions representative.

Trademarks

The word "Actions" and the logo are the trademarks of Actions Semiconductor Co., Ltd, and Actions (Zhuhai) Technology Co., Limited is authorized to use them. Word "炬芯" is the trademark of Actions (Zhuhai) Technology Co., Limited. Names and brands of other companies and their products that may from time to time descriptively appear in this document are the trademarks of their respective holders, no affiliation, authorization, or endorsement by such persons are claimed or implied except as may be expressly stated therein.

Rights Reserved

The provision of this document shall not be deemed to grant buyers any right in and to patent, copyright, trademark, trade secret, know how, and any other intellectual property of Actions or others.

Miscellaneous

Information contained or described herein relates only to the Actions products and as of the release date of this publication, abrogates and supersedes all previously published data and specifications relating to such products provided by Actions or by any other person purporting to distribute such information.

Actions reserves the rights to make changes to information described herein at any time without notice. Please contact your Actions sales representatives to obtain the latest information before placing your

product order.

Additional Support

Additional products and company information can be obtained by visiting the Actions website at: <http://www.actions-semi.com>

List of Contents

Declaration.....	2
List of Contents	4
Features.....	5
Applications	5
Application Diagram	5
Specifications	5
Electrical Characteristics	6
AUDIO Features	7
RF Characteristics	13
PMU Characteristics	16
Module Pin definitions.....	18
Pin Configurations	18
Module Package Information	20
Document History	22
Contact Information	22

Features

- 104 MHz MIPS32 Processor and 180 MHz DSP
- Internal ROM and serial flash memory interface supporting randomizer
- Internal RAM for data and program
- Built-in high performance stereo 24 bit DAC & ADC
- Supports Digital microphones, single-ended Analog microphones and full difference microphone
- Built-in stereo PA for headphone and differential audio output for speaker PA
- Bluetooth V4.2 compatible with Bluetooth V4.1, V4.1 BLE, V3.0, V2.1 systems
- Bluetooth fast AGC control to improve receiving dynamic range
- Supports AFH to dynamically detect channel quality to improve Bluetooth transmission quality
- Support SD/MMC/eMMC card interface and SPI Nor Flash interface
- Audio Interfaces: I2S, SPDIF TX
- Serial Interfaces: USB2.0, UART, TWI, SPI
- Infrared Remote controller supported
- Segment LCD panels
- Digital matrix LED panels
- Integrated PMU supports multiple low energy States
- Integrated Linear battery charger up to 600mA charging current
- PCB Dimension: 24.9mm (L) × 14mm (W) × 0.8mm (H)

Applications

- Stereo headsets and headphones
- Portable stereo speakers and speakerphones
- Bluetooth car audio unit
- Bluetooth sound bar
- Bluetooth smart LED

More Information please visit:

<http://www.actions-semi.com>

ATS2825 Bluetooth Module

Bluetooth Audio Solution

**Low Power Solution for
Portable & Wireless Audio Applications
Local MMC/SD Card Audio Playback**

**MIPS + DSP Dual-core Single-chip
Bluetooth V4.2
Revision V1.1**

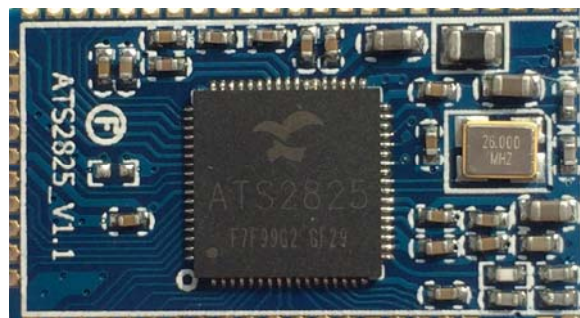

ATS2825 provides wireless and local high quality music and support wireless calls with low power and BOM, making it competitive at high-end Bluetooth audio products market. Above all, ATS2825 delivers a true “ALL-IN-ONE” solution; it is the ideal choice for Single-chip wireless and local MMC/SD card audio application

Application Diagram

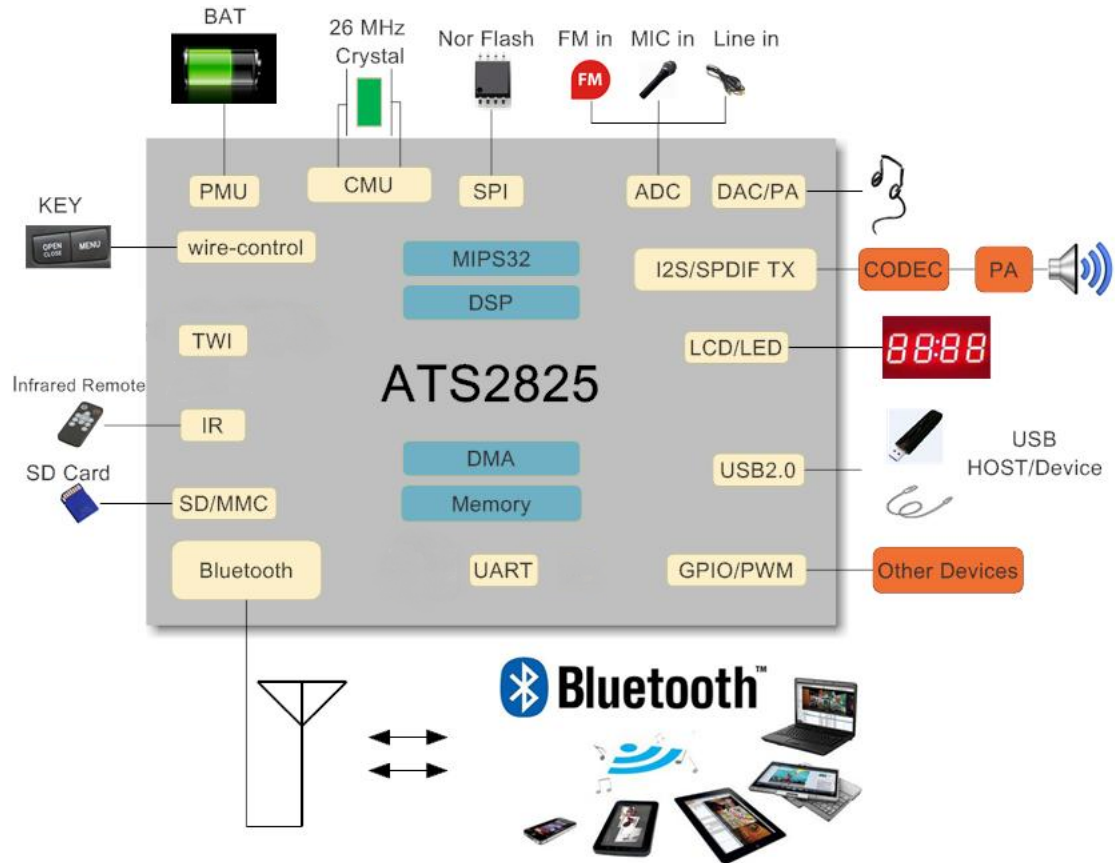

Specifications

Operating Frequency Band	2.4GHz ~ 2.48GHz unlicensed ISM band
Bluetooth Specification	V2.1+EDR/V3.0/V4.0/ V4.1/V4.1 BLE/V4.2
Bluetooth Protocol	A2DP,AVRCP,HFP,SPP BAS,DIS,FMP,HRP,HRS,HTP,HTS,IAS,LLS
Output Power Class	Class 2
Operating Voltage	Core :1.2V, IO:3.3V, BAT:3.4V~4.2V
Operating temperate range	-10 °C ~ +70 °C
External Interface	UART,SPI,TWI,I2S,IR,SD Card,USB,DMIC,SPDIF TX

Electrical Characteristics

Absolute Maximum Ratings				
Parameter	Symbol	Min	Max	Unit
Temperature	Storage temperature (T_{stg})	-55	+150	°C
ESD Stress voltage	V_{ESD} (Human body model)	2000	-	V
Supply Voltage	DC5V	-0.3	9.0	V
	BAT	-0.3	5.0	V
	VCC/AVCC/BTVCC	-0.3	3.6	V
	VDD	-0.3	1.32	V
Input Voltage	3.3V IO	-0.3	3.6	V
	1.2V IO	-0.3	1.32	V

Recommended Power Supply				
Supply Voltage	Min	Typ	Max	Unit
BAT (Li)	3.4	3.8	4.3	V
DC5V	4.5	5.0	7.0	V
VCC/AVCC/BTVCC	2.8	3.1	3.4	V
VD15	1.0	1.5	1.7	V
VDD/RTCVD	1.08	1.2	1.32	V
VD12	0.8	1.05	1.5	V

Regulators Maximum Output Current		
Block Name	Output Voltage	Load Capacity
VCC	2.7V ~ 3.4V	300mA
VDD	0.8V ~ 1.32V	100mA
VD15	1.0V ~ 1.7V	170mA
BTVCC	2.8V ~ 3.5V	100mA
AVCC	VCC - 0.15V	50mA@98%

Note: The output voltages are precisely within $\pm 2\%$, providing large currents with a significantly small dropout voltage within $\pm 5\%$.

AUDIO Features

Test Condition: Power BAT=3.8V, Analog audio output AOURL/R, Load = 10K ohm,
 BW=20Hz ~ 20 KHz, A-Weight. Test equipment: AP2700.

Audio Codec	DAC/ADC Sampling rate	Max : 48K Typical : 44.1K Min : 8K
Audio performance DAC (0Hz/1KHz,A weight)	Output Level	Max : 960mVrms Typical : 940 mVrms
	Ground Noise	Max : 10 uV Typical : 7 uV
	DAC SNR	Max : 101dB Typical : 98dB
	DAC THD+N	Min: -87dB Typical : -85 dB
	Dynamic Range	Max : 101 dB Typical : 98dB
	Crosstalk	Min : -100 dB Typical : -96dB
	Frequency Response	20Hz ~20KHz
Audio performance ADC (0Hz/1KHz,A weight)	Input Level THD+N <1%	Max : 980mVrms Min : --
	Ground Noise	Max : 40 uVrms Typical : 30 uVrms
	ADC SNR	Max : 90 dB Typical : 87 dB
	ADC THD+N	Min : -82dB Typical : -80 dB
	Dynamic Range	Max : 85 dB Typical : 82dB
	Crosstalk	Min : -85 dB Typical : -82dB
	Frequency Response	20Hz ~20KHz

DAC/ADC audio output performance chart:

Card Player Music Mode :

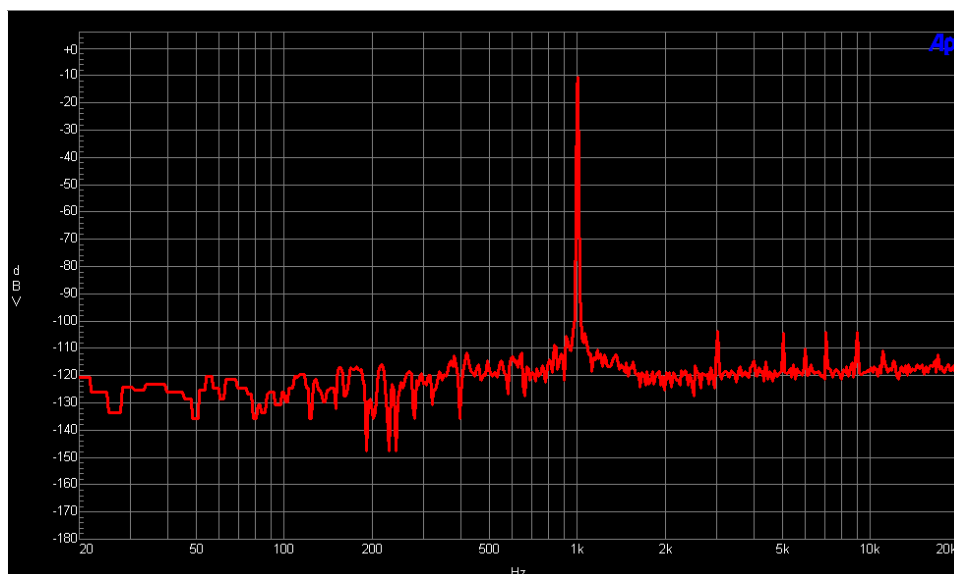

Card player: 1KHz Sin wave FFT 20Hz ~ 20 KHz

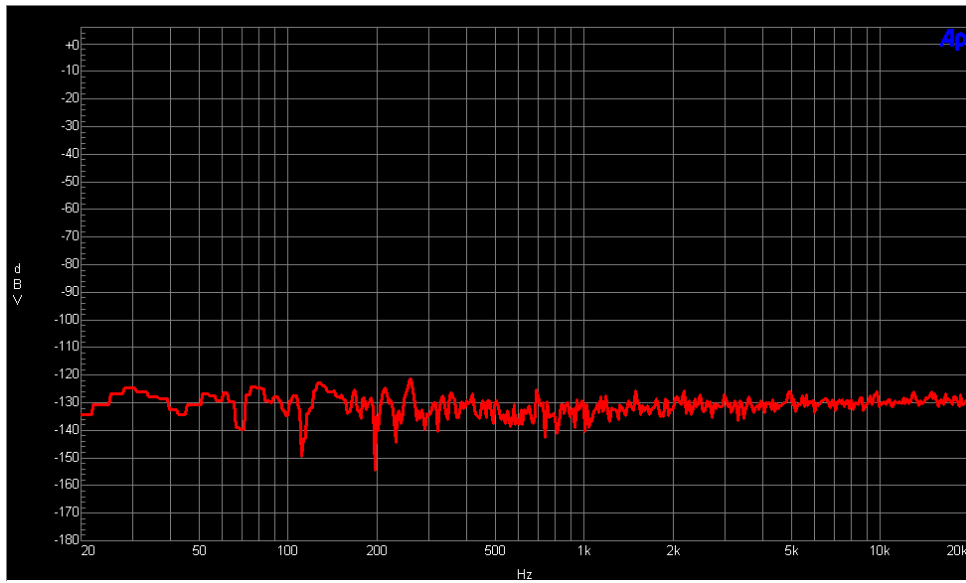

Card Player: 0Hz FFT 20Hz ~ 20 KHz

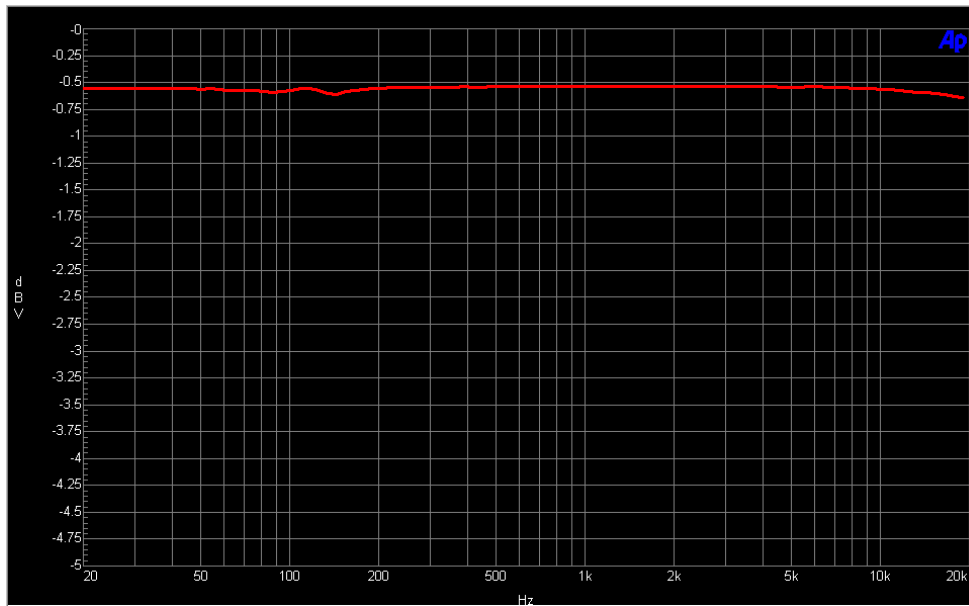

Card Player: Frequency Response 20Hz ~ 20 KHz

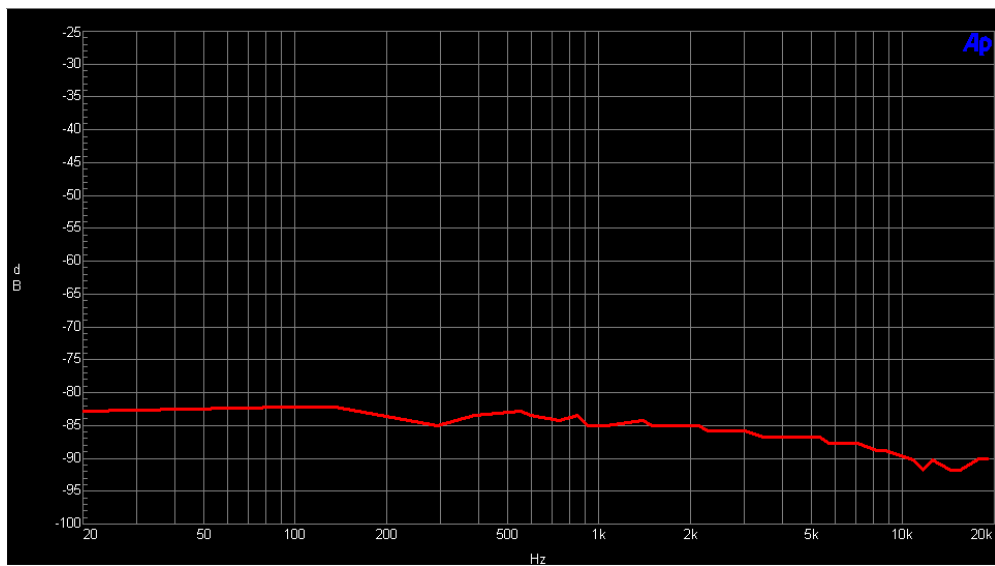

Card Player: THD+N Distortion 20Hz ~ 20 KHz

Line in Input Mode:

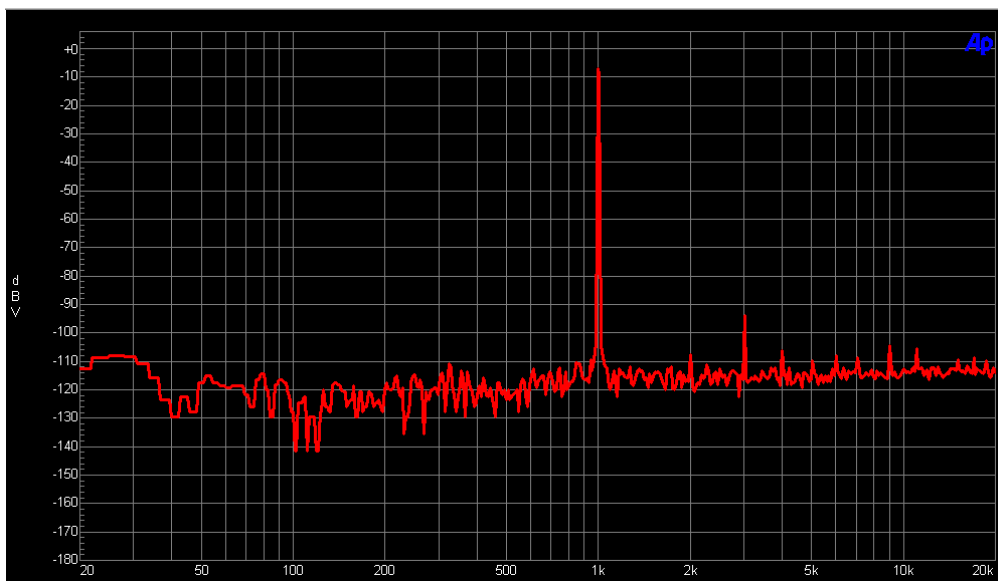

Line in Input player: 1KHz Sin wave FFT 20Hz ~ 20 KHz

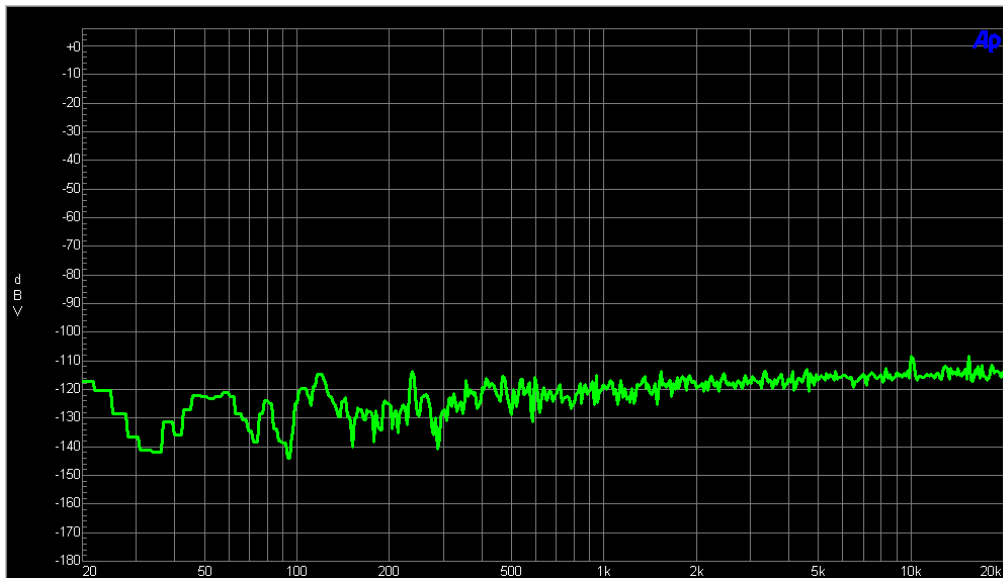

Line in Input player: 0KHz FFT 20Hz ~ 20 KHz

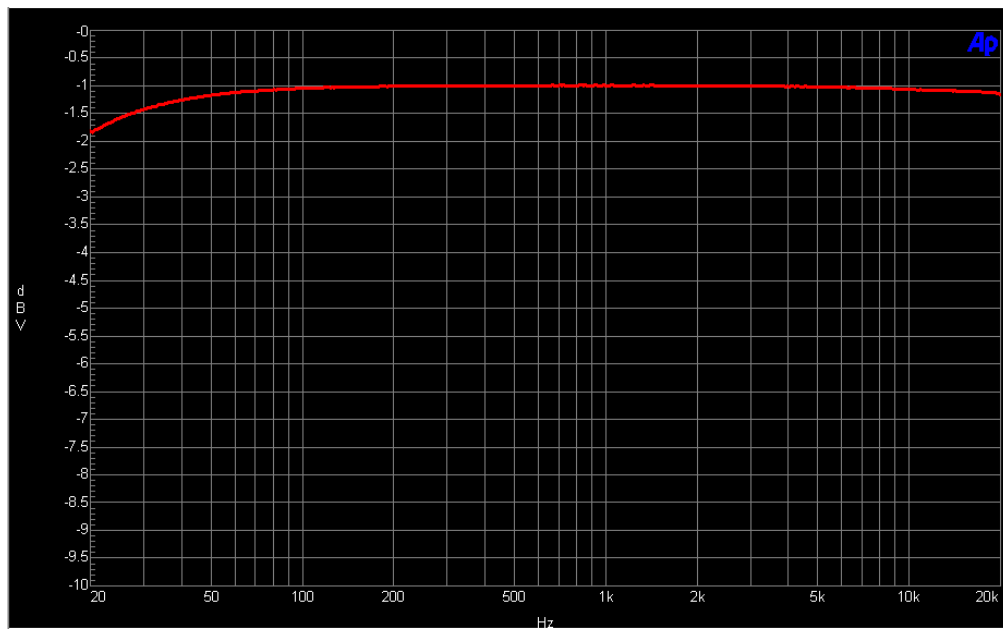

Line in Input Player: Frequency Response 20Hz ~ 20 KHz

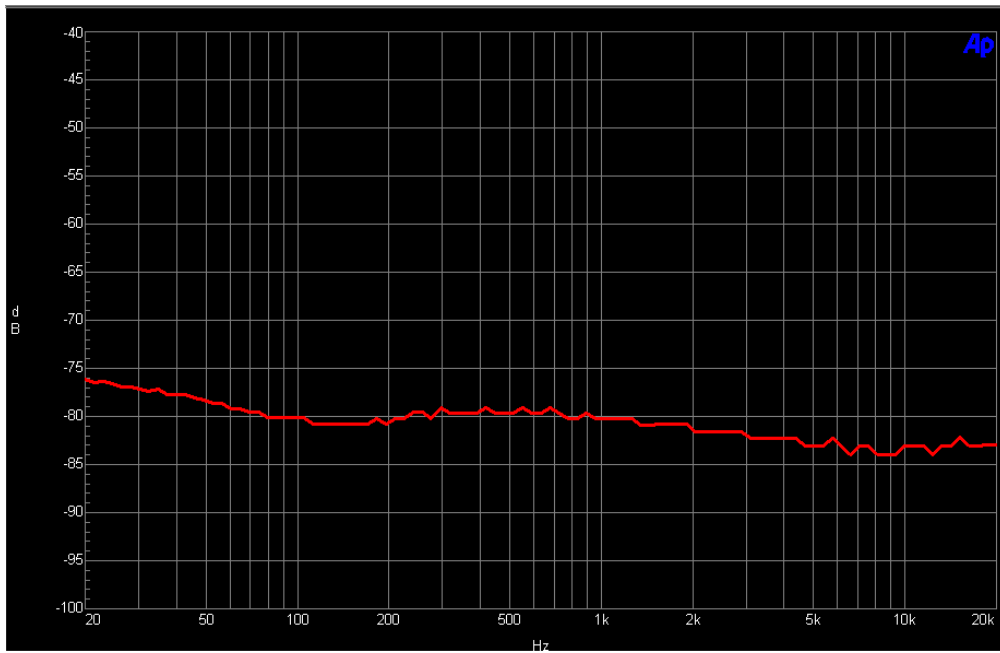

Line in Input player: THD+N Distortion 20Hz ~ 20 KHz

Bluetooth Player Music Mode:

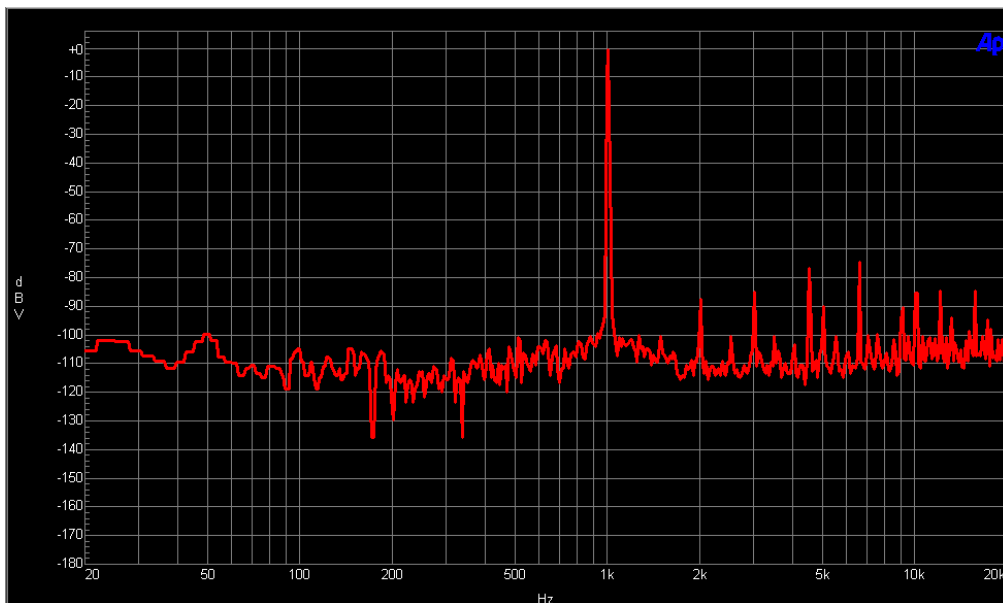

Bluetooth A2DP Player: 1KHz Sin wave FFT 20Hz ~ 20 KHz

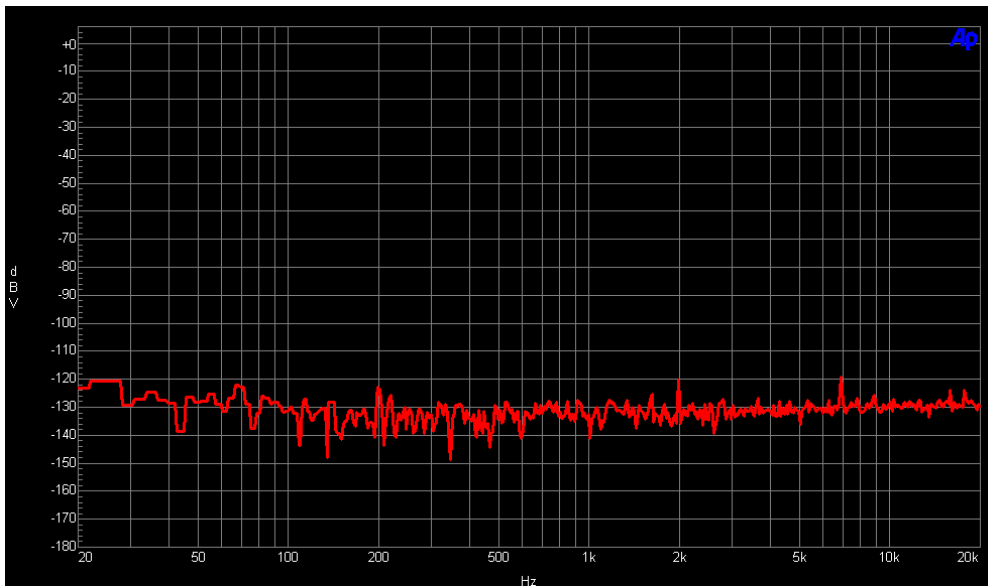

Bluetooth A2DP Player: 0Hz FFT 20Hz ~ 20 KHz

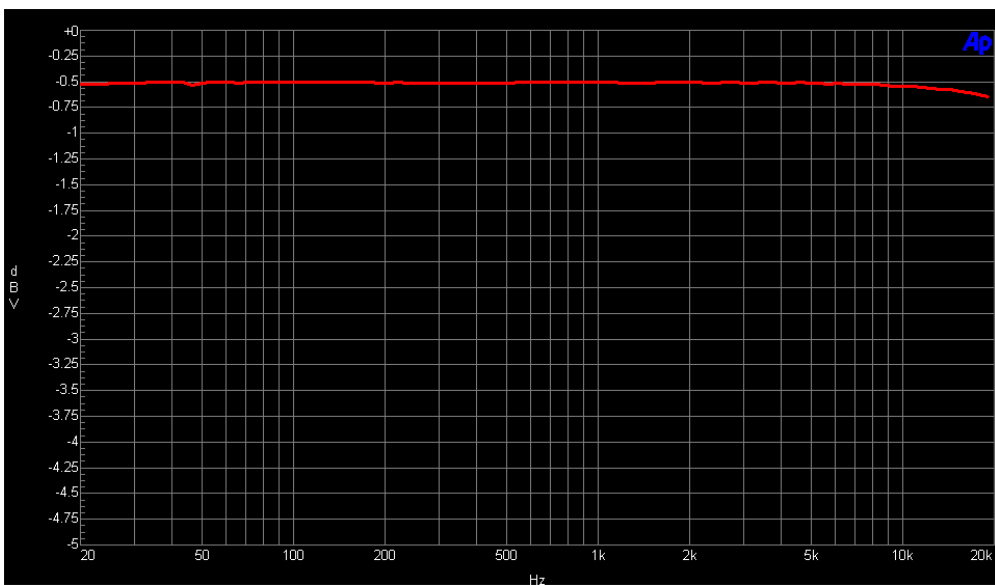

Bluetooth A2DP Player: Frequency Response 20Hz ~ 20 KHz

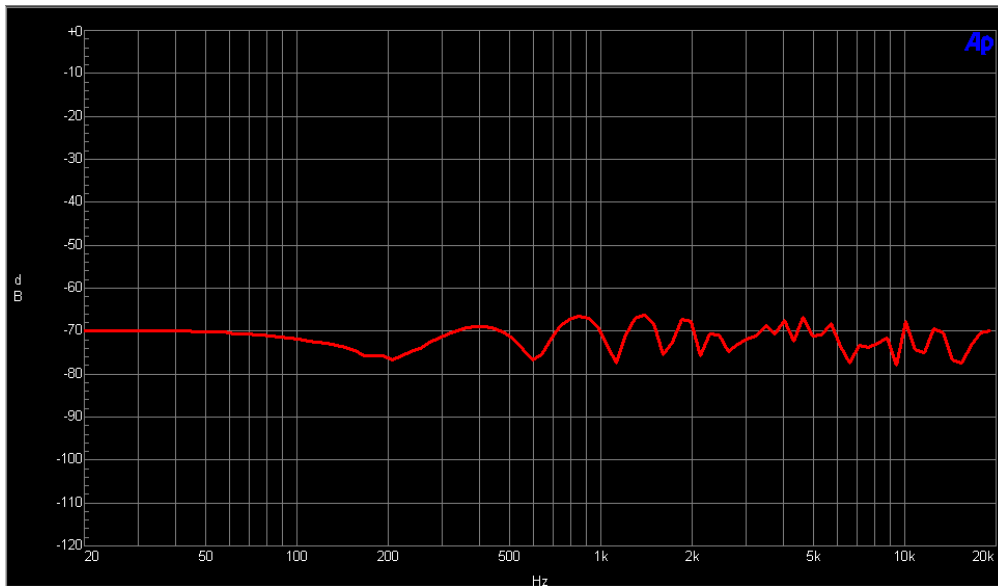

Bluetooth A2DP Player: THD+N Distortion 20Hz ~ 20 KHz

RF Characteristics

Test conditions:

1. BAT=3.8V, VCC=3.1V, VDD=1.2V, Tamb=25°C.
2. BLE ON, SPP OFF, Scan time:1.28S, DAE OFF, No Load.

BT Protocols	A2DP/AVRCP/HFP /SPP	A2DP1.3
		AVRCP1.6
		HFP1.7
		SPP1.2
Power Consumption	A2DP	Typical : 21mA
	HFP	Typical : 26mA
	Sniff	Typical : 0.6mA
	Standby	Typical : 38uA
Distance	A2DP	Max:50M Typical : 20M
	HFP	Max : 20M Typical : 10M

Basic Data Rate of Transmitter

Core Supply Voltage = 1.05V @ Tamb=25°C

Parameter	Condition	Min.	Typ.	Max.	Unit
Maximum RF Transmit Power			2	4	dBm
RF Power Control Range		2	3	8	dB
20dB Bandwidth for Modulated Carrier			930	990	KHz
Adjacent Channel Transmit	+2 MHz	-47	-52		dBm
	-2 MHz	-51	-52		dBm
	+3 MHz	-40	-58		dBm
	-3 MHz	-56	-57		dBm
Frequency Deviation	Δf_{1avg} Maximum	140	170	175	KHz
	Δf_{2max} Maximum	100%	100%		
	$\Delta f_{1avg}/\Delta f_{2avg}$	0.89	0.9	0.91	
Initial Carrier Frequency Tolerance		3	5	6	KHz
Frequency Drift	HD1 Packet	-9	-8	8	KHz
	HD3 Packet	-8	-9	-10	KHz
	HD5 Packet	-10	-7	-6	KHz
Frequency Drift Rate		3	4	5	KHz/50us
Harmonic Content			-50		dBm

Enhanced Data Rate of Transmitter

Core Supply Voltage = 1.05V @ Tamb=25°C

Parameter	Condition	Min.	Typ.	Max.	Unit
Relative Transmit Power			-0.4		dB
$\pi/4$ DQPSK max carrier frequency stability $ \omega_0 $		-10		10	KHz
$\pi/4$ DQPSK max carrier frequency stability $ \omega_i $		-75		75	KHz
$\pi/4$ DQPSK max carrier frequency stability $ \omega_0+\omega_i $		-75		75	KHz
8DPSK max carrier frequency stability $ \omega_0 $		-10		10	KHz
8DPSK max carrier frequency stability $ \omega_i $		-75		75	KHz
8DPSK max carrier frequency stability $ \omega_0+\omega_i $		-75		75	KHz
$\pi/4$ DQPSK Modulation	RMS DEVIN		7	20	%

Accuracy	99% DEVM	99	100		%
	Peak DEVM		18	35	%
8DPSK Modulation Accuracy	RMS DEVIN		6	13	%
	99% DEVM	99	100		%
	Peak DEVM		18	25	%
In-band spurious emissions	$F > F_0 + 3\text{MHz}$			-40	dBm
	$F < F_0 - 3\text{MHz}$			-40	dBm
	$F = F_0 + 3\text{MHz}$			-40	dBm
	$F = F_0 - 3\text{MHz}$			-40	dBm
	$F = F_0 + 2\text{MHz}$			-20	dBm
	$F = F_0 - 2\text{MHz}$			-20	dBm
	$F = F_0 + 1\text{MHz}$			-26	dB
$F = F_0 - 1\text{MHz}$			-26	dB	
EDR Differential Phase Encoding		99	100		%

Basic Data Rate of Receiver					
Core Supply Voltage = 1.05V @ Tamb = 25°C					
Parameter	Condition	Min.	Typ.	Max.	Unit
Sensitivity at 0.1% BER	2.404GHz		-90		dBm
	2.441GHz		-90		dBm
	2.480GHz		-90		dBm
Maximum Input Power at 0.1% BER		-20			dBm
Co-Channel Interface				11	dB
Adjacent Channel Selectivity C/I	$F = F_0 + 1\text{MHz}$			0	dB
	$F = F_0 - 1\text{MHz}$			0	dB
	$F = F_0 + 2\text{MHz}$			-20	dB
	$F = F_0 - 2\text{MHz}$			-20	dB
	$F = F_0 + 3\text{MHz}$			-40	dB
	$F = F_{\text{image}}$			-9	dB
Maximum Level of Intermediation Interface		-39			dBm
Blocking @ Pin = -67dBm with 0.1% BER	30-2000 MHz	-10	-8		dBm
	2000-2400 MHz	-27	-25		dBm
	2500-3000 MHz	-27	-25		dBm
	3000-12750 MHz	-10	-8		dBm

Enhanced Data Rate of Receiver					
Core Supply Voltage = 1.05V @ Tamb=25°C					
Parameter	Condition	Min.	Typ.	Max.	Unit
Sensitivity at 0.01% BER	$\pi/4$ DQPSK		-88		dBm
	8DPSK		-82		dBm
Maximum Input Power at 0.1% BER	$\pi/4$ DQPSK	-20			dBm
	8DPSK	-20			dBm
Co-Channel Interference	$\pi/4$ DQPSK		13		dB
	8DPSK		21		dB
Adjacent Channel Selectivity C/I	F = F ₀ + 1MHz	$\pi/4$ DQPSK		0	dB
		8DPSK		5	dB
	F = F ₀ - 1MHz	$\pi/4$ DQPSK		0	dB
		8DPSK		5	dB
	F = F ₀ + 2MHz	$\pi/4$ DQPSK		-30	dB
		8DPSK		-25	dB
	F = F ₀ - 2MHz	$\pi/4$ DQPSK		-20	dB
		8DPSK		-13	dB
	F = F ₀ + 3MHz	$\pi/4$ DQPSK		-40	dB
		8DPSK		-33	dB
	F = F _{image}	$\pi/4$ DQPSK		-7	dB
		8DPSK		0	dB

PMU Characteristics

PMU	Charging current	Max : 600mA Typical : 500mA
	Charger input voltage	Max : 7.0V Typical : 5V Min : 4.5V
Power Consumption	Test conditions: 2. BAT=3.8V, VCC=3.1V, VDD=1.2V, Tamb=25°C. 3. BLE ON, SPP OFF, Scan time:1.28S, DAE OFF, No Load.	
	Standby	38 uA (type)
	Card music play	13 mA (type)
	Line in music play	10.4 mA (type)

	Bluetooth music play	20.6mA	(type)
	Bluetooth hands free	26.4 mA	(type)

Charge Flow Chart and Settings :

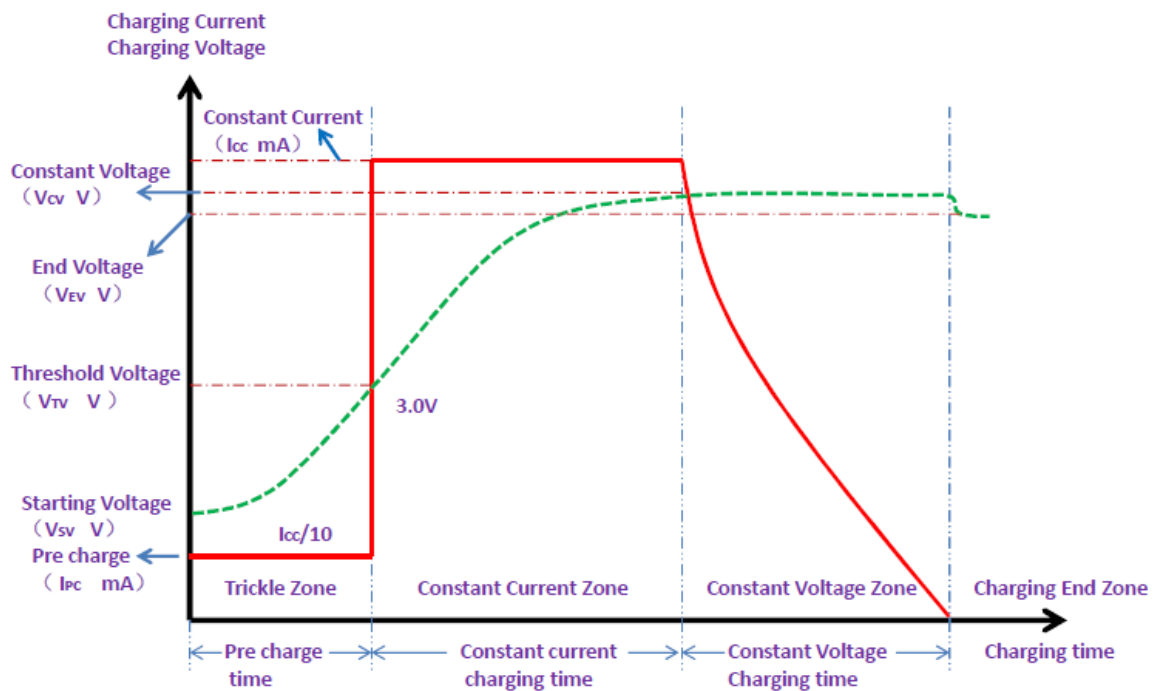

Charge Flow Chart

Note :

1. Charging process is divided into 3 stages: the pre charge process, the constant current process and the constant voltage process.
2. The pre charge current (I_{pc}) is 0.1 times the constant current charge current (I_{cc}).
Or $I_{pc} = 0.1 \times I_{cc}$ (mA); Disable this function by set [CHG_CTL.bit14] =0, default is disable.
3. When the starting charge voltage to 3.0V (V_{tv}), the pre charging process is over, and the charging process is entered into the constant current charging process.
4. Set the constant current charging current I_{cc} , constant current charge continues to the battery voltage to V_{cv} , switch to the constant voltage charging process. I_{cc} current can be set with 8 levels of parameters: 000:25mA, 001:50mA, 010:100mA, 011:200mA, 100:300mA, 101:400mA, **110:500mA**, 111:600mA.
5. V_{cv} voltage can be set with 8 levels of parameters: 000:4.2V, 001:4.23V, 010:4.26V, 011:4.29V, 100:4.32V, 101:4.35V, 110:4.38V, 111:4.41V.
6. After the end of the charge, the Li-BAT voltage is generally $V_{ev} = 4.18V \pm 0.05V$.

Module Pin definitions

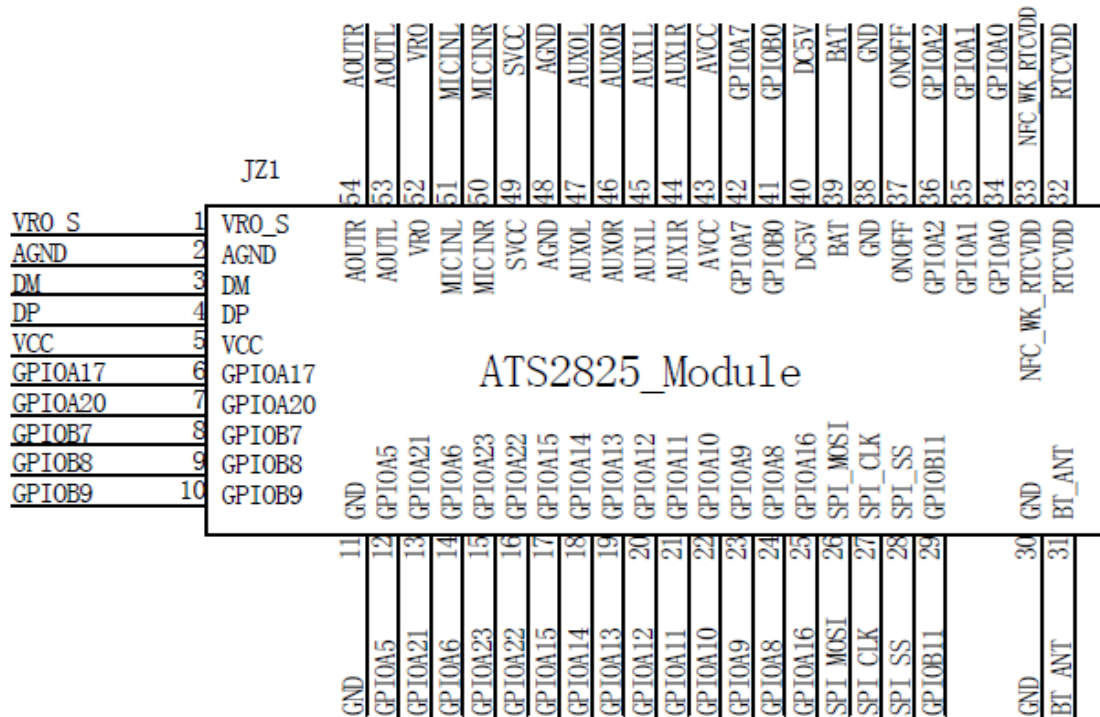

L x W x H = 24.9 x 14 x 0.8 (mm)

Pin Configurations

PIN NO.	NAME	TYPE	FUNCTION
1	VRO_S	Analog input	VRO Sense for PA
2	AGND	Power ground	Analog ground
3	DM	Bi-directional	USB D-
4	DP	Bi-directional	USB D+
5	VCC	Power output	3.3V power supply
6	GPIOA17	Bi-directional	General Purpose Input Output: A17

7	GPIOA20	Bi-directional	General Purpose Input Output: A20
8	GPIOB7	Bi-directional	General Purpose Input Output: B7
9	GPIOB8	Bi-directional	General Purpose Input Output: B8
10	GPIOB9	Bi-directional	General Purpose Input Output: B9
11	GND	Power ground	Ground
12	GPIOA5	Bi-directional	General Purpose Input Output: A5
13	GPIOA21	Bi-directional	General Purpose Input Output: A21
14	GPIOA6	Bi-directional	General Purpose Input Output: A6
15	GPIOA23	Bi-directional	General Purpose Input Output: A23
16	GPIOA22	Bi-directional	General Purpose Input Output: A22
17	GPIOA15	Bi-directional	General Purpose Input Output: A15
18	GPIOA14	Bi-directional	General Purpose Input Output: A14
19	GPIOA13	Bi-directional	General Purpose Input Output: A13
20	GPIOA12	Bi-directional	General Purpose Input Output: A12
21	GPIOA11	Bi-directional	General Purpose Input Output: A11
22	GPIOA10	Bi-directional	General Purpose Input Output: A10
23	GPIOA9	Bi-directional	General Purpose Input Output: A9
24	GPIOA8	Bi-directional	General Purpose Input Output: A8
25	GPIOA16	Bi-directional	General Purpose Input Output: A16
26	SPI_MOSI	Bi-directional	SPI data
27	SPI_CLK	Bi-directional	SPI clock
28	SPI_SS	Bi-directional	SPI chip enable
29	GPIOB11	Bi-directional	General Purpose Input Output: B11
30	GND	Power ground	Ground
31	BT_ANT	Bi-directional	Bluetooth antenna junction
32	RTCVDD	Power output	power for RTC Module, typical voltage:1.2V
33	NFC_WK_RTCVD D	Input	NFC wake signal input
34	GPIOA0	Bi-directional	General Purpose Input Output: A0
35	GPIOA1	Bi-directional	General Purpose Input Output: A1
36	GPIOA2	Bi-directional	General Purpose Input Output: A2
37	ONOFF	Input	Power on/off
38	GND	Power ground	Ground
39	BAT	Power input	Battery input, typical voltage range :3.4V ~ 4.2V
40	DC5V	Power input	USB power input, typical voltage range :4.5V ~ 7.0V
41	GPIOB0	Bi-directional	General Purpose Input Output: B0

42	GPIOA7	Bi-directional	General Purpose Input Output: A7
43	AVCC	Power output	Power for Analog module, typical voltage:2.95V
44	AUX1R	Analog input	AUX1 right channel input
45	AUX1L	Analog input	AUX1 left channel input
46	AUX0R	Analog input	AUX0 right channel input
47	AUX0L	Analog input	AUX0 left channel input
48	AGND	Analog ground	Analog ground
49	SVCC	Power output	Power for Standby
50	MICINR	Analog input	MIC right channel input
51	MICINL	Analog input	MIC left channel input
52	VRO	Analog output	Virtual Ground for PA
53	AOUTL	Analog output	Left channel of PA
54	AOUTR	Analog output	Right channel of PA

Module Package Information

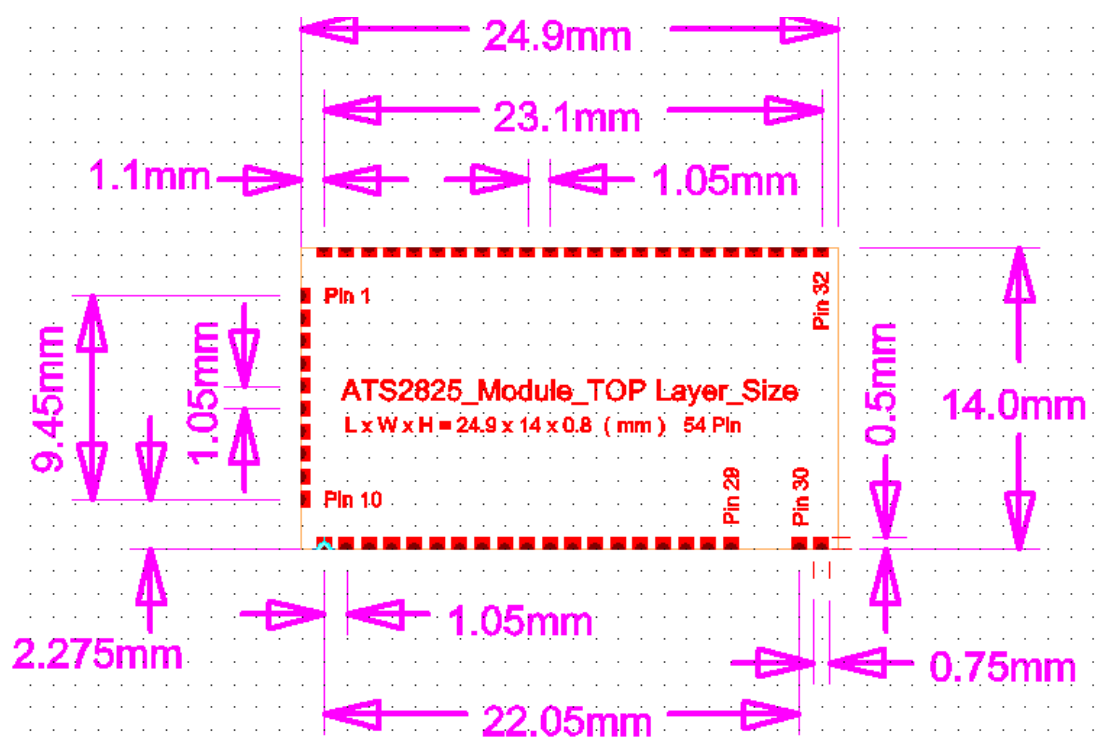

Module Dimension (Top VIEW)

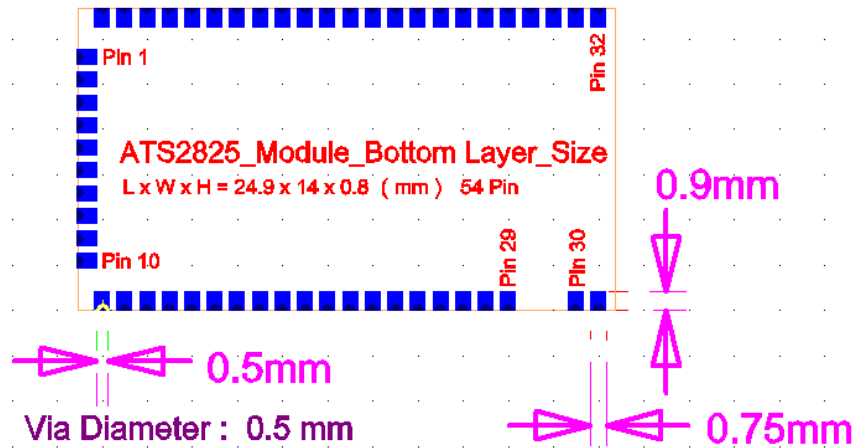

Module Dimension (Bottom VIEW)

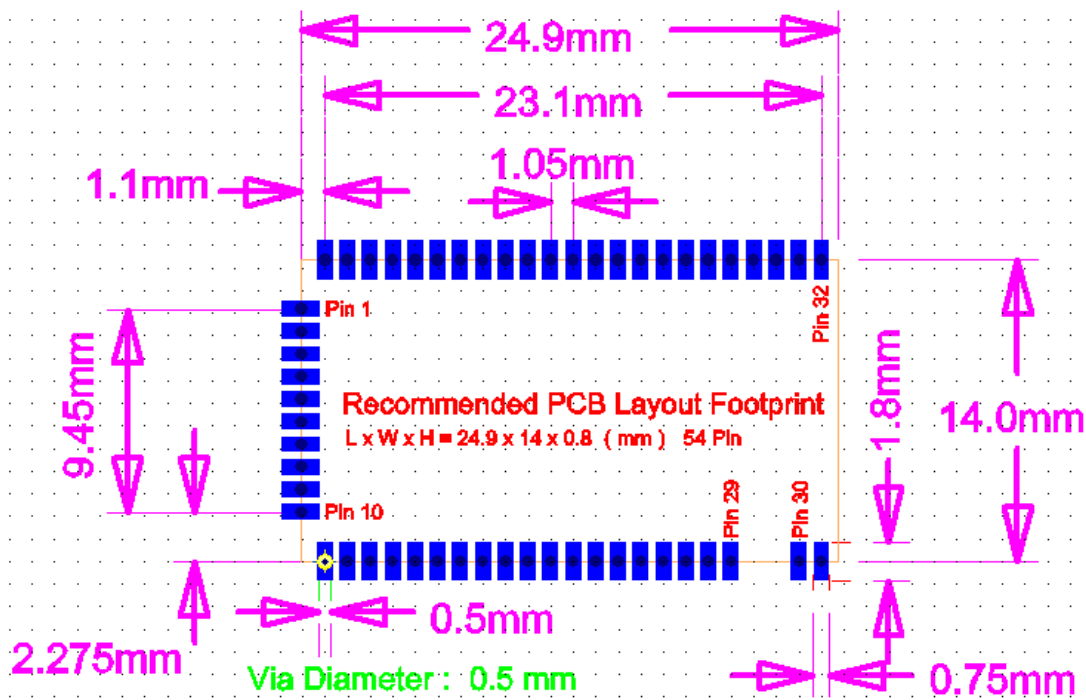

Recommended PCB layout footprint

Document History

Revision	Date	History
V1.0	2015/06/09	First release
V1.1	2015/10/26	Update PMU and Audio .

Contact Information

Actions (Zhuhai) Technology Co.,Limited

<http://www.actions-semi.com>

Address:

No. 1 / C, Ke Ji Si Road, Hi-Tech Zone,
Tangjia, Zhuhai

Post Code: 519085

Fax: +86-756-3392251

Tel: +86-756-3392353

Business Email:

mmp-sales@actions-semi.com

Technical Service Email:

mmp-cs@actions-semi.com