

---

## 2W Class-K Audio Amplifier with RF-TDD Suppression and NCN

### Features

- **Built-In RNS Function, Excellent TDD Suppression**
- **NCN Function Protects the Speaker**
- **EEE Function, Greatly reduces EMI over the full bandwidth**
- **2.0W into 8Ω at 4.2V(10% THD+N)**
- **4 Selectable Gain, 12dB, 16dB, 24dB, 27.5dB**
- **4 Mode selected by one-wire pulse**
- **Excellent Pop-Click Suppression**
- **Short-Circuit and Thermal Protection**
- **±7KV HBM ESD, ±450mA Latch-up**
- **Small 3mm×3mm 20-Pin TQFN Package**

### Applications

- Cellular Phones
- Portable Audio Devices
- Mini Speakers

### General Description

The AW8733A is a powerful Class-K audio amplifier that features RNS (RF-TDD Noise Suppression), NCN (Non-Crack-Noise) and EEE (Enhanced Emission Elimination).

The AW8733A features the RNS function which greatly reduces RF-TDD Noise.

The AW8733A features a built-in charge pump converter generates a 6.3V supply voltage. This provides a louder audio output than a stand-alone amplifier directly connected to the battery. The AW8733A features 2W output power (10% THD+N) into 8Ω load at 4.2V battery voltage.

The AW8733A features the NCN function, which adjusts the system gain automatically while detecting the “Crack” distortion of output signal, protects the speaker from damage at high power levels and brings the most comfortable listening experience to the customers.

The AW8733A is available in a small 3mm×3mm 20-Pin TQFN Package. It is specified over the extended -40°C to +85°C temperature range.

## Pin Configuration and Top Mark

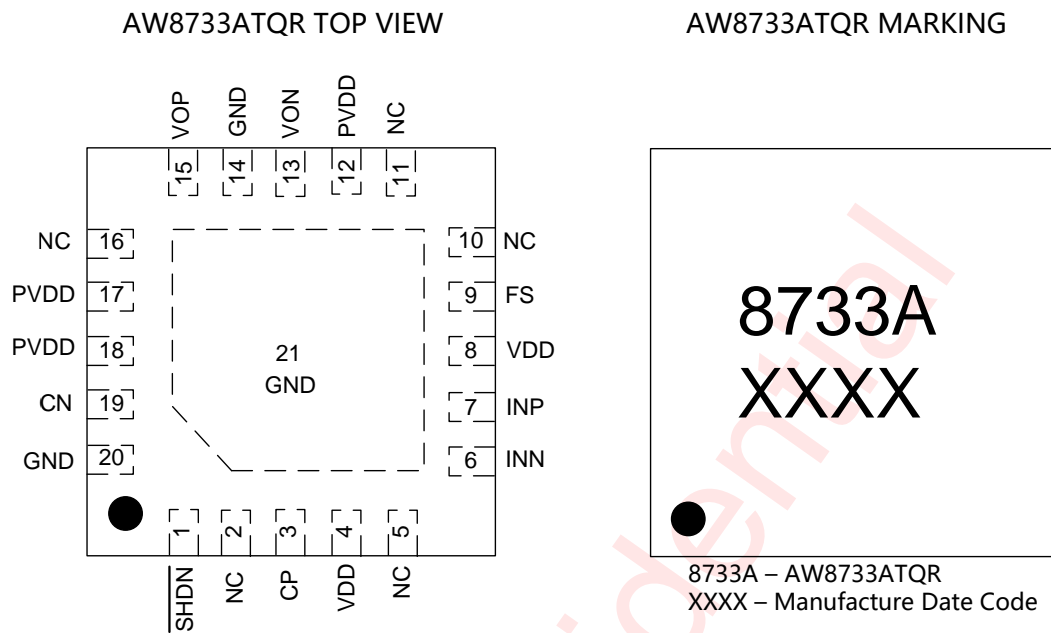

Figure 1 Pin Configuration and Top Mark of AW8733ATQR

## Pin Definition and Function

No.	Symbol	Description
1	SHDN	Shutdown and one-wire control pin
3	CP	Positive Terminal of Flying capacitor
4, 8	VDD	Supply Voltage.
6	INN	Negative Amplifier Input
7	INP	Positive Amplifier Input
9	FS	Test pin. No Connect
12, 17, 18	PVDD	Charge-Pump Output.
13	VON	Negative Amplifier output
14, 20	GND	Ground
15	VOP	Positive Amplifier Output
19	CN	Negative Terminal of Flying capacitor.
21	GND	Exposed Pad. Connect to GND.
2, 5, 10, 11, 16	NC	No Connect

Typical Application

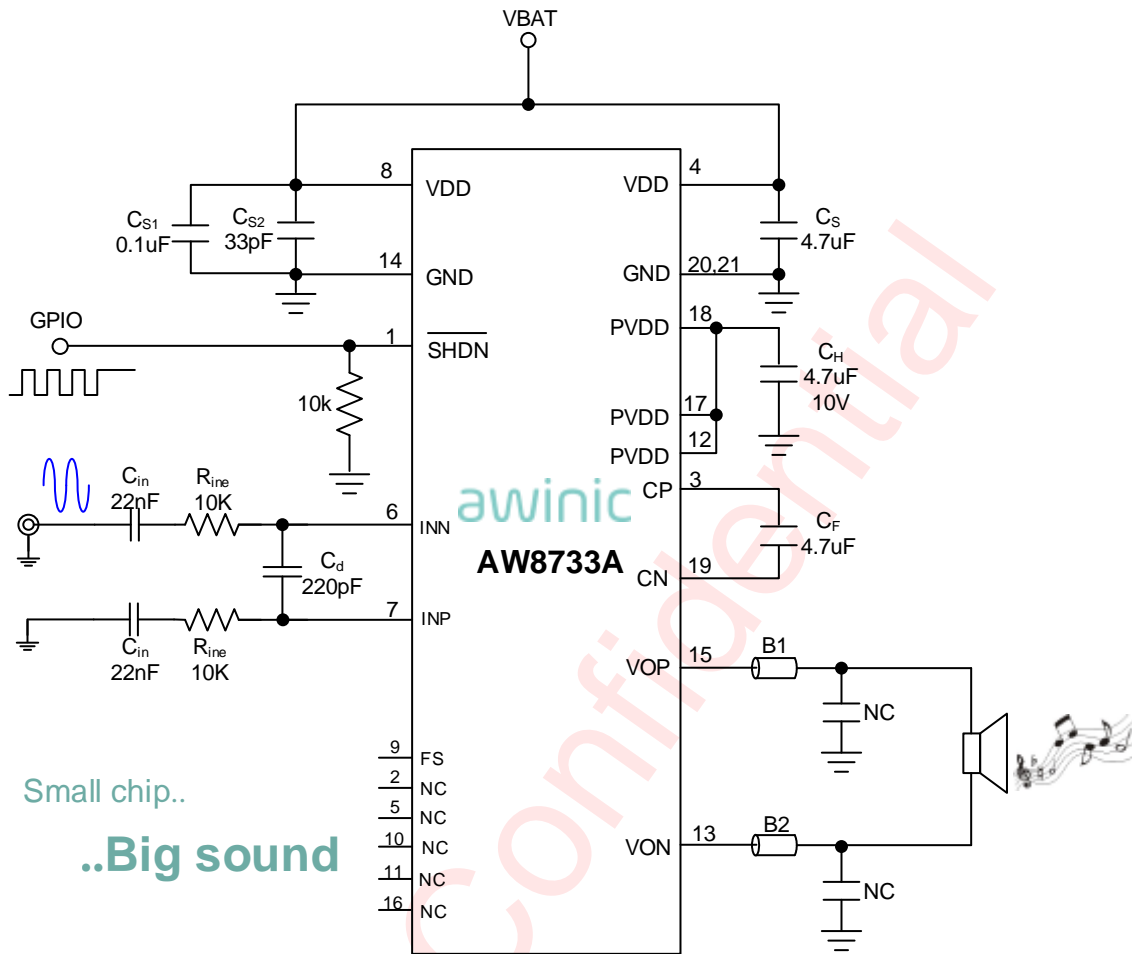

Figure 2 AW8733A Application Schematic With Single-Ended Input

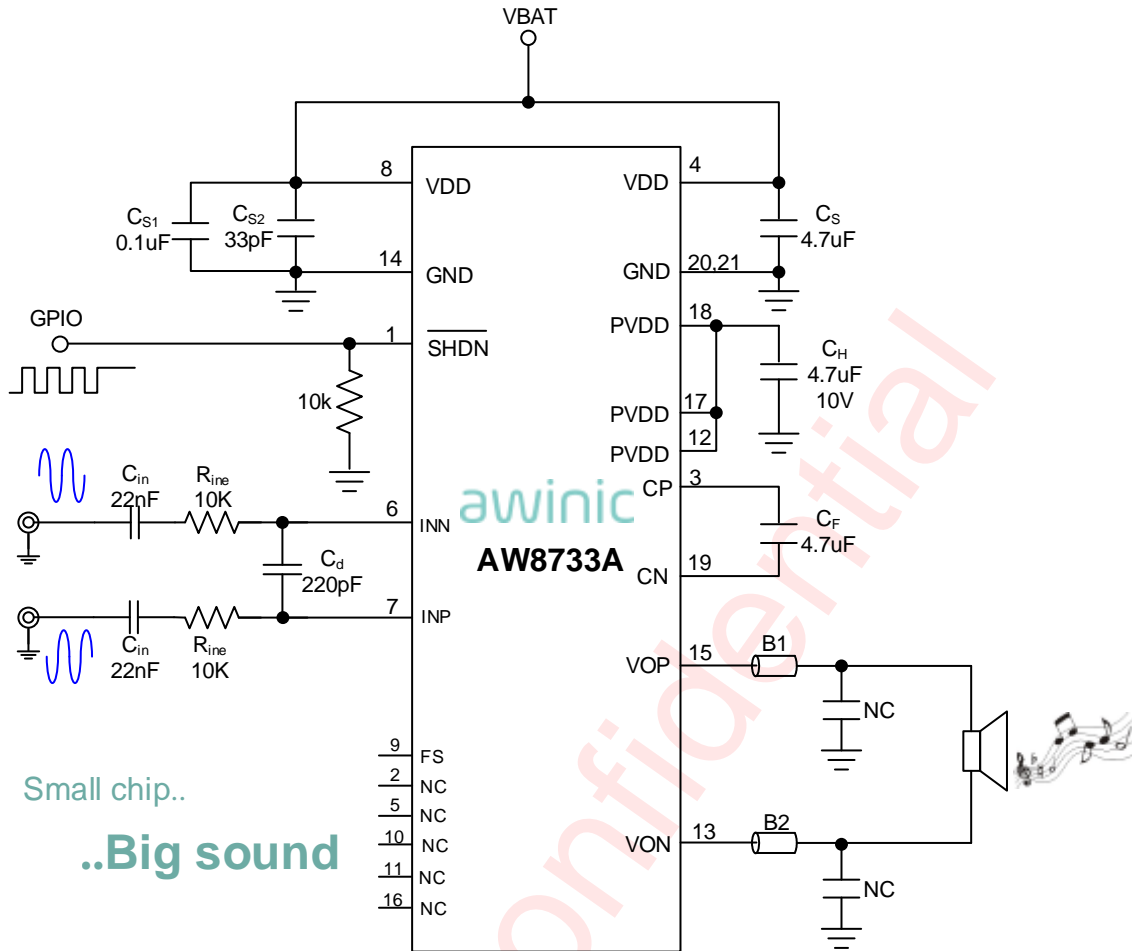
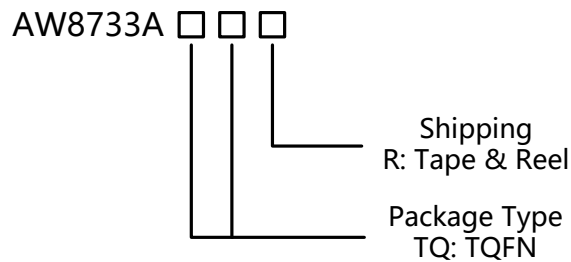

Figure 3 AW8733A Application Schematic With Differential Input

### Ordering Information

Part Number	Temperature	Package	Marking	Moisture Sensitivity Level	Environmental Information	Packing Type
AW8733ATQR	-40°C ~ 85°C	3mmX3mm 20-Pin TQFN	8733A	MSL3	RoHS+HF	6000 units/Tape and Reel



**Absolute Maximum Ratings (1)**

Parameter	Unit
Supply voltage $V_{DD}$	-0.3V to 7V
INP、INN、SHDN Pin Voltage	-0.3V to $V_{DD}+0.3V$
Package Thermal Resistance $\theta_{JA}$	54°C/W
Operating free-air temperature	-40°C to 85°C
Maximum Junction Temperature $T_{JMAX}$	125°C
Storage Temperature Range $T_{STG}$	-65°C to 150°C
Lead Temperature (Soldering 10 Seconds)	260°C
ESD Rating (2)	
HBM(human body model)	±7KV
Latch-up	
Test Condition: JEDEC STANDARD NO.78D NOVEMBER 2011	+IT: 450mA -IT: -450mA

**note1:** Stresses beyond those listed under "absolute maximum ratings" may cause permanent damage to the device. These are stress ratings only and functional operation of the device at these or any other conditions beyond those indicated under "recommended operating conditions" is not implied. Exposure to absolute-maximum-rated conditions for extended periods may affect device reliability.

**note2:** The human body model is a 100pF capacitor discharged through a 1.5kΩ resistor into each pin. Test method: MIL-STD-883H Method 3015.8.

## Electrical Characteristics

Test Condition:  $T_A=25^{\circ}\text{C}$ ,  $R_L=8\Omega+33\mu\text{H}$  (Unless otherwise specified)

Parameter	Conditions	Min	Typ	Max	Units
$V_{DD}$ Power Supply		2.5		5.5	V
$I_q$ Quiescent current			7		mA
$I_{SD}$ Shutdown current	$V_{DD}=3.6\text{V}$ , $\overline{\text{SHUTDOWN}}=0\text{V}$		0.1		$\mu\text{A}$
$V_{IH}$ $\overline{\text{SHDN}}$ high-level input		1.2		$V_{DD}$	V
$V_{IL}$ $\overline{\text{SHDN}}$ low-level input		0		0.35	V
$I_{IH}$ $\overline{\text{SHDN}}$ high-level input current	$\overline{\text{SHDN}}$ , $V_{DD}=5.5\text{V}$ , $V_{IH}=5.8\text{V}$			100	$\mu\text{A}$
$I_{IL}$ $\overline{\text{SHDN}}$ low-level input current	$\overline{\text{SHDN}}$ , $V_{DD}=5.5\text{V}$ , $V_{IH}=-0.3\text{V}$			5	$\mu\text{A}$
$T_{SD}$ Thermal Protect level			160		$^{\circ}\text{C}$
$T_{SDH}$ Thermal Hysteresis			40		$^{\circ}\text{C}$
<b>Charge Pump</b>					
PVDD Output Voltage	$V_{DD}=3.3\text{V to }5.5\text{V}$ , no load	5.8	6.3	7	V
F1 Switching Frequency	$V_{DD}=3\text{V to }5.5\text{V}$		600		kHz
$T_{ST}$ Soft-start time	No load, $\text{COUT}=10\mu\text{F}$		0.5		ms
$I_L$ PVDD short to GND current limit			300		mA
<b>Class K</b>					
$ V_{OS} $ Output offset voltage	$V_{IN}=0\text{V}$ , no load	-30	0	30	mV
Rini Internal impedance	Mode1 and Mode2		30		k $\Omega$
	Mode3 and Mode4		5		
Fosc Modulation Frequency	$V_{DD}=2.5\text{V to }5.5\text{V}$		300		kHz
PSRR Power supply rejection ratio	$V_{DD}=4.2\text{V}$ , $V_{p-p\_sin}=200\text{mV}$	217Hz		70	dB
		1kHz		68	dB
$T_{ON}$ Start-up time			28		ms
THD+N Total harmonic distortion plus noise	$V_{DD}=4.2\text{V}$ , $P_o=1\text{W}$ , $f=1\text{kHz}$		0.2		%
	$V_{DD}=3.6\text{V}$ , $P_o=0.5\text{W}$ , $f=1\text{kHz}$		0.23		%
$P_o$ Output power	THD+N=10%, $f=1\text{kHz}$ , $V_{DD}=4.2\text{V}$		2		W
	THD+N=1%, $f=1\text{kHz}$ , $V_{DD}=4.2\text{V}$		1.7		W
<b>one-wire pulse control</b>					
$T_H$ $\overline{\text{SHDN}}$ high level hold time	$V_{DD}=2.5\text{V to }5.5\text{V}$	0.75	2	10	$\mu\text{s}$
$T_L$ $\overline{\text{SHDN}}$ low level hold time	$V_{DD}=2.5\text{V to }5.5\text{V}$	0.75	2	10	$\mu\text{s}$
$T_{OFF}$ $\overline{\text{SHDN}}$ delay time	$V_{DD}=2.5\text{V to }5.5\text{V}$			500	$\mu\text{s}$
<b>NCN</b>					
$T_{AT}$ Attack time	$f_{sin}=1\text{kHz}$		40		ms
$T_{RL}$ Release time			1.2		s
$A_{MAX}$ Maximum attenuation gain			-6		dB

## Measurement System

AW8733A features switching output signal. As shown in Figure 4. A Low-Pass RC filter can be used to remove high switching frequency in output signal.

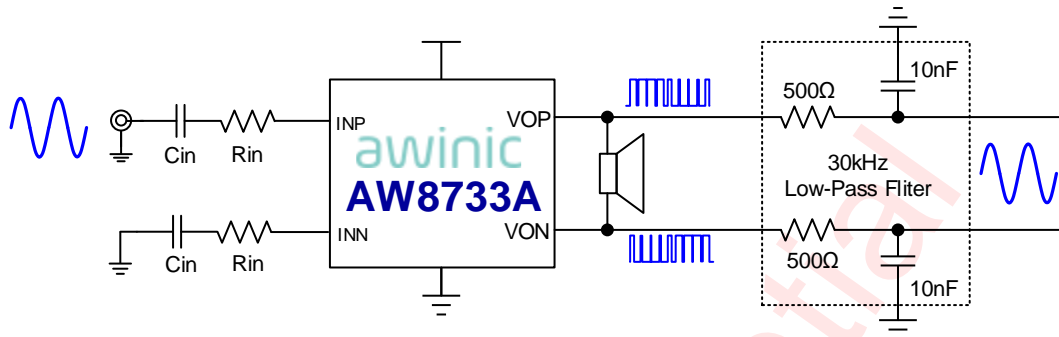

Figure 4 AW8733A measurement system

Table 1 shows recommended values of  $R_{\text{filter}}$  and  $C_{\text{filter}}$ .

$R_{\text{filter}}$	$C_{\text{filter}}$	Low-pass cutoff frequency
500Ω	10nF	32kHz
1kΩ	4.7nF	34kHz

Table1 Typical RC Measurement Filter Values

## Typical Operating Characteristics

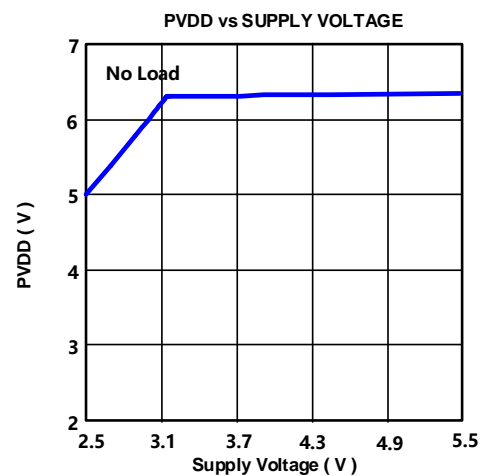
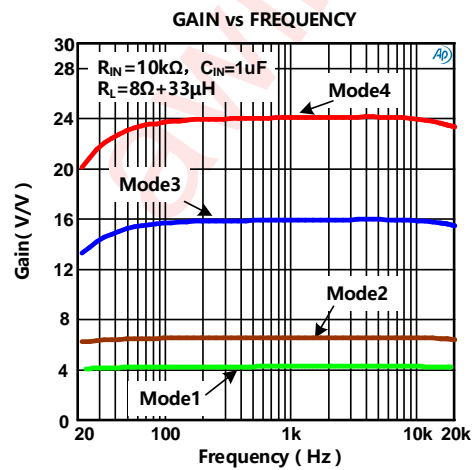
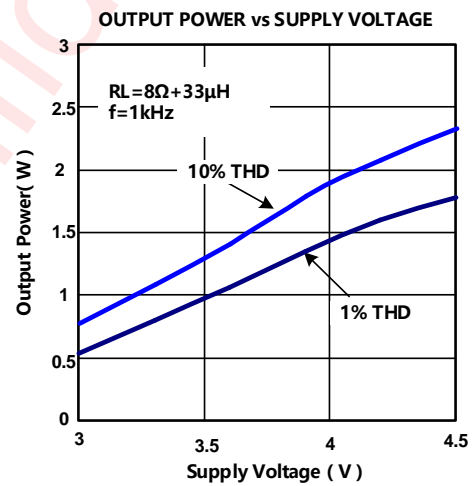
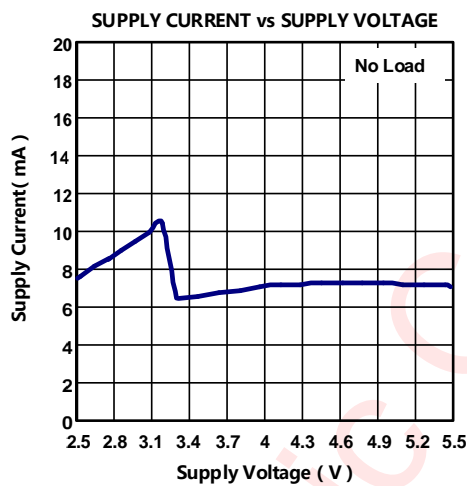
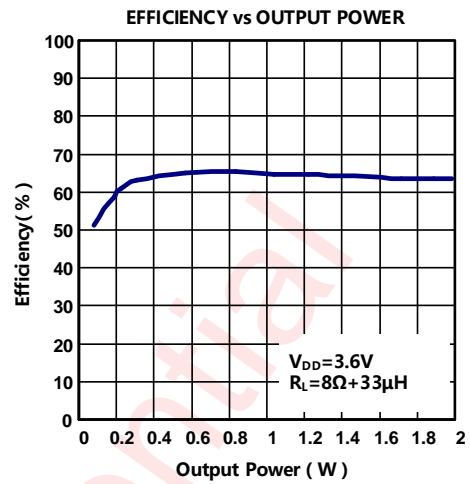
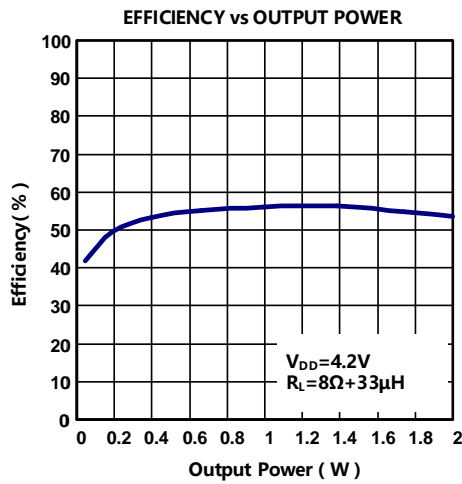



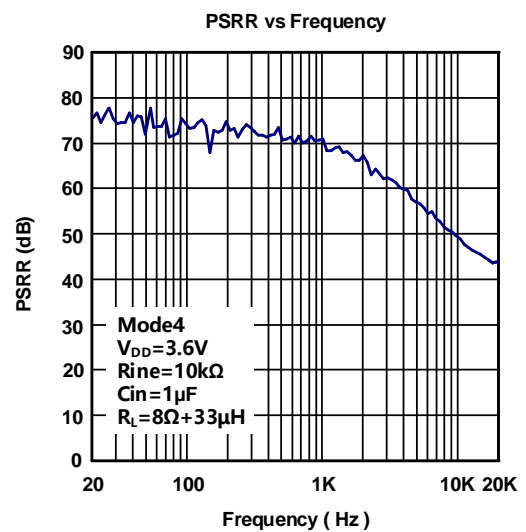
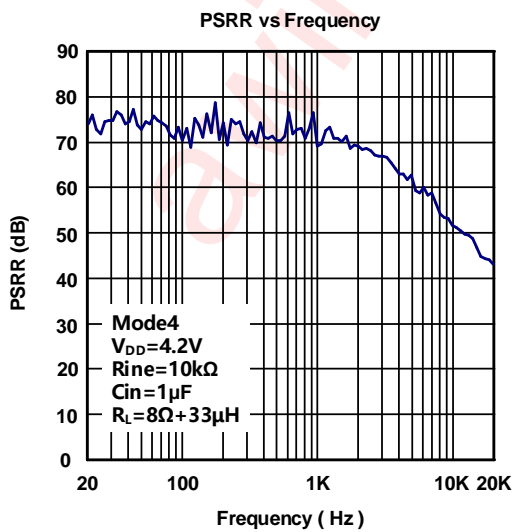
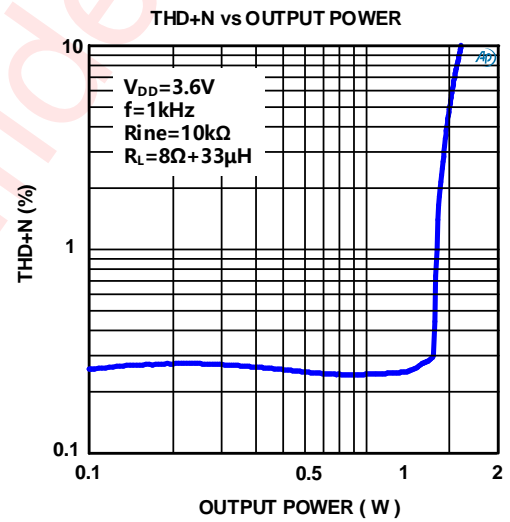
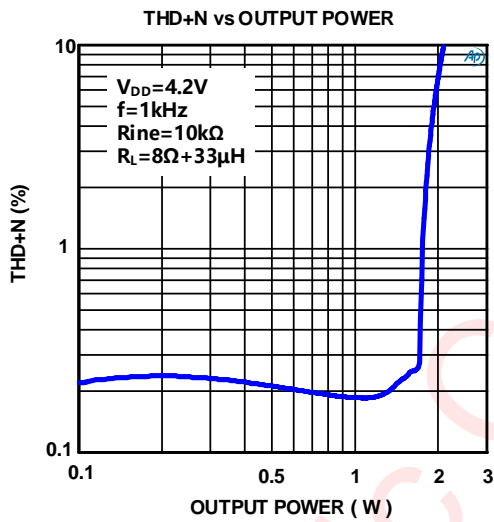
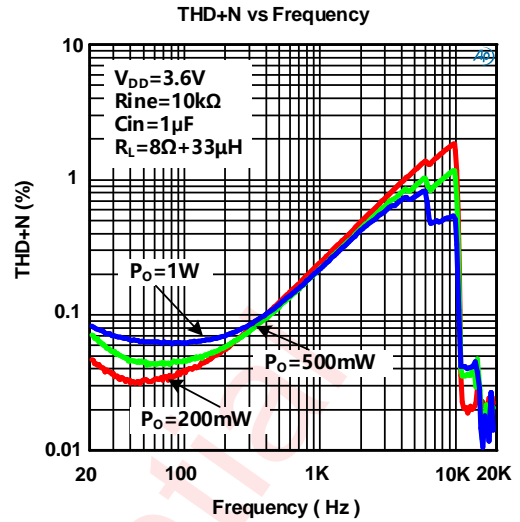
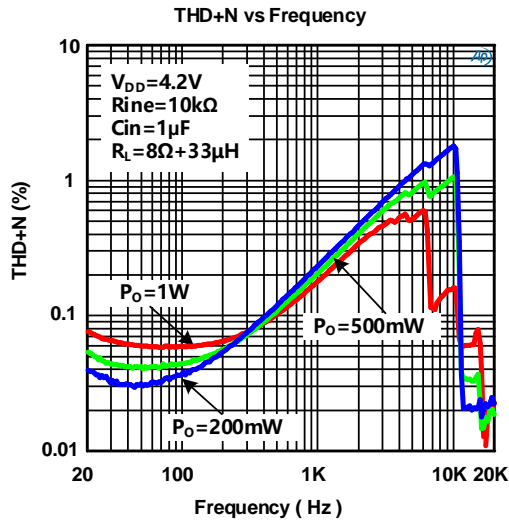

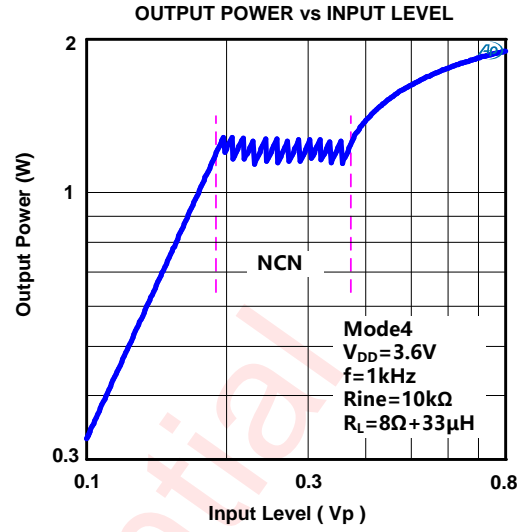
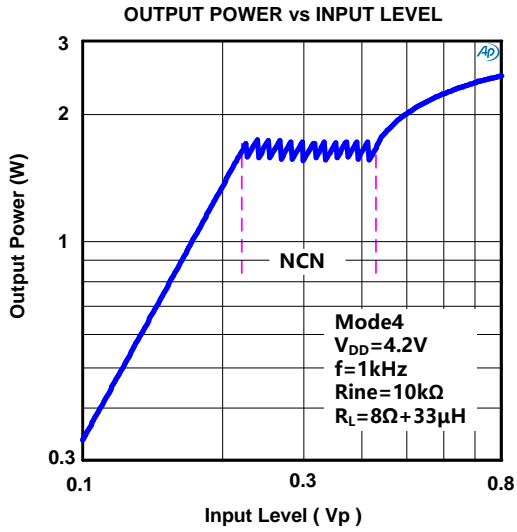

**NCN ATTACK TIME**

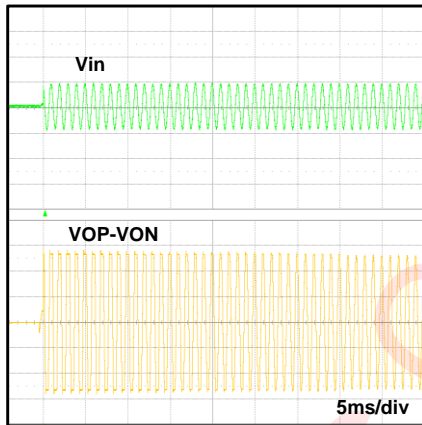

**NCN RELEASE TIME**

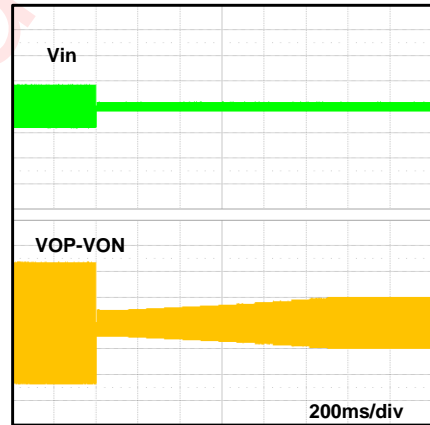

**STARTUP TIME**

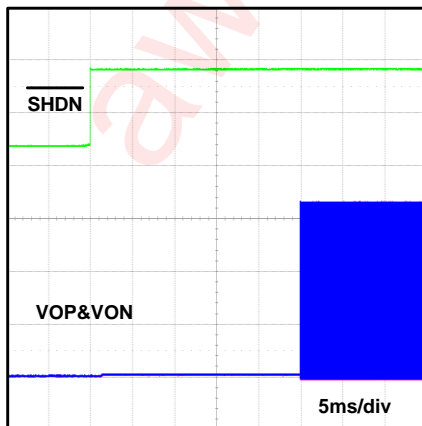

**SHDN TIME**

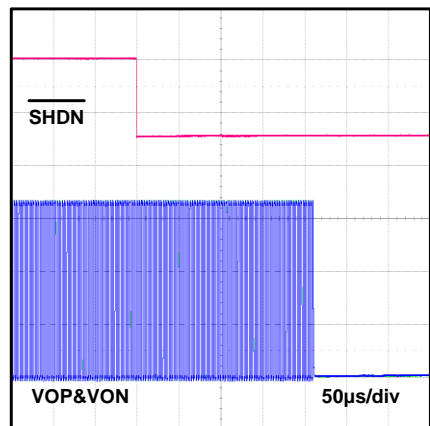

## Block Diagram

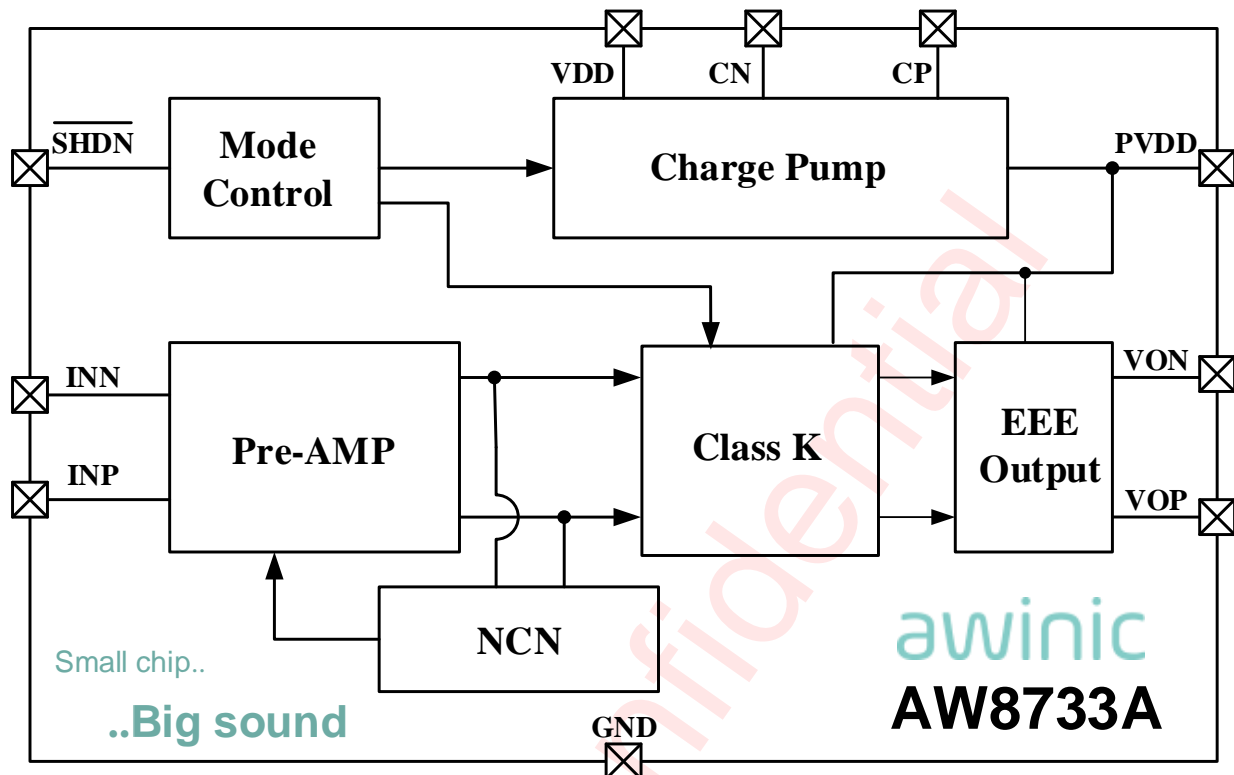

Figure 5 Functional Block Diagram of AW8733A

## Operation

The AW8733A is a powerful Class-K audio amplifier that features RNS (RF-TDD Noise Suppression), NCN (Non-Crack-Noise) and EEE (Enhanced Emission Elimination).

The AW8733A features the RNS function which greatly reduces RF-TDD Noise.

The AW8733A features a built-in charge pump converter generates a 6.3V supply voltage. This provides a louder audio output than a stand-alone amplifier directly connected to the battery. The AW8733A features 2W output power (10% THD+N) into 8Ω load at 4.2V battery voltage.

The AW8733A features the NCN function, which adjusts the system gain automatically while detecting the “Crack” distortion of output signal, protects the speaker from damage at high power levels and brings the most comfortable listening experience to the customers.

The AW8733A is available in a small 3mm×3mm 20-Pin TQFN Package. It is specified over the extended -40°C to +85°C temperature range.

### One-wire pulse control

AW8733A select each mode by one-wire pulse control, as shown in figure 6. When  $\overline{\text{SHDN}}$  pin pull high form shutdown mode, there is one rising edge, AW8733A start to work and set Gain=12dB. When high-low-high signal set to  $\overline{\text{SHDN}}$  pin, there are two rising edges, AW8733A open NCN function and set Gain=16dB. When there are three rising edges, AW8733A close NCN function and set Gain=24dB. When there are four rising edges, AW8733A open NCN function and set Gain=27.5dB.

As shown in figure 6, when  $\overline{\text{SHDN}}$  pull down above 500us, AW8733A will enter shutdown mode.

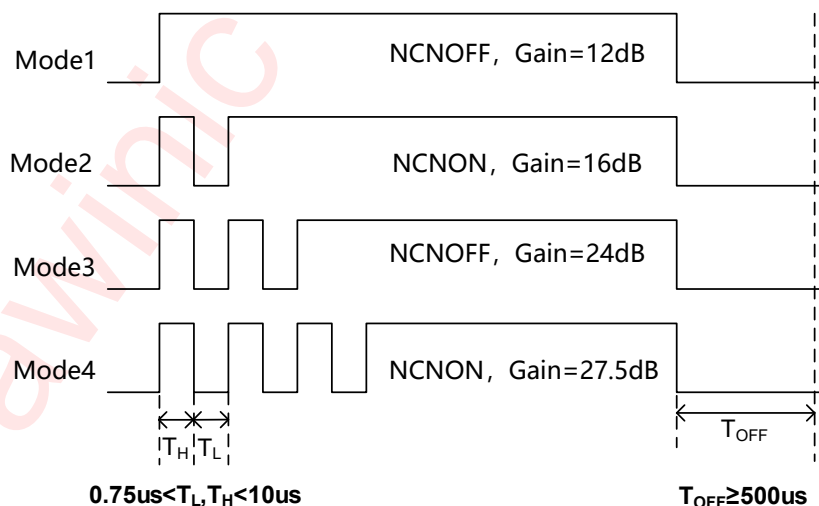

Figure 6 One-Wire pulse control

### RNS (RF TDD Noise Suppression)

GSM radios transmit using time-division multiple access with 217Hz intervals. The result is an RF signal with strong amplitude modulation at 217Hz and its harmonics that is easily demodulated by audio amplifiers.

In RF applications, improvements to both layout and component selection decrease the AW8733A's susceptibility to RF noise and prevent RF signals from being demodulated into audible noise. Minimizing the trace lengths prevents them from functioning as antennas and coupling RF signals into the AW8733A. Additional RF immunity can also be obtained from relying on the self-resonant frequency of capacitors as it exhibits the frequency response similar to a notch filter. Depending on the manufacturer, 10pF to 20pF capacitors typically exhibit self resonance at RF frequencies. These capacitors, when placed at the input pins, can effectively shunt the RF noise at the inputs of the AW8733A. For these capacitors to be effective, they must have a low-impedance, low-inductance path to the ground plane.

Some RF energy will couple onto audio traces regardless of the effort to prevent this phenomenon from occurring, form audible TDD Noise. The AW8733A features a unique RNS technology, which effectively reduces RF energy, attenuates the RF TDD-noise, an acceptable audible level to the customer.

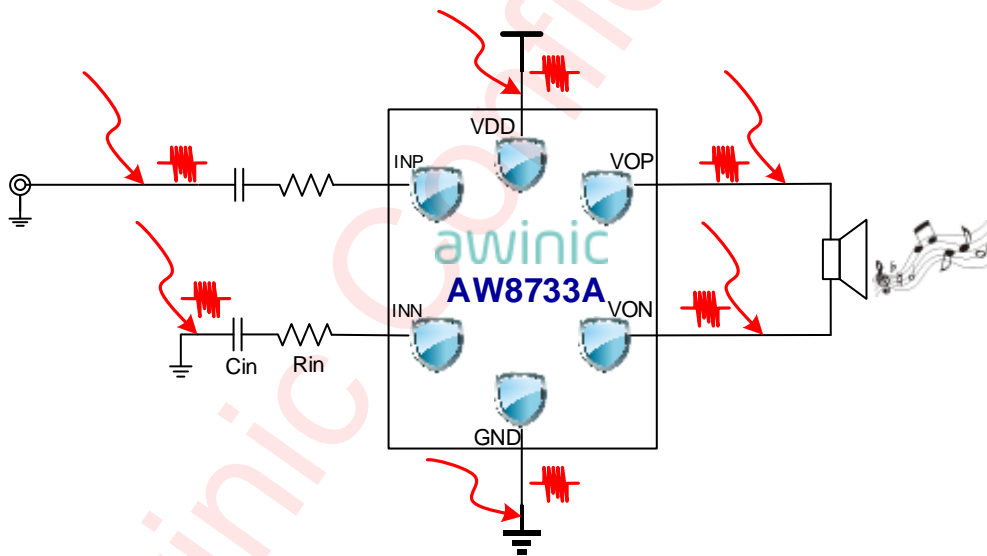

Figure 7 RF Energy Coupling Diagram

### NCN

In audio application, output signal will be undesirable distortion caused by too large input and power supply voltage down with battery, and clipped output signal may cause permanent damage to the speaker. The AW8733A features unique non-crack-noise (NCN) Function, which adjusts system gain automatically to generate desired output by detecting the "Crack" distortion of output signal, protects the speaker from damage at high power levels and brings the most comfortable listening experience to the customers.

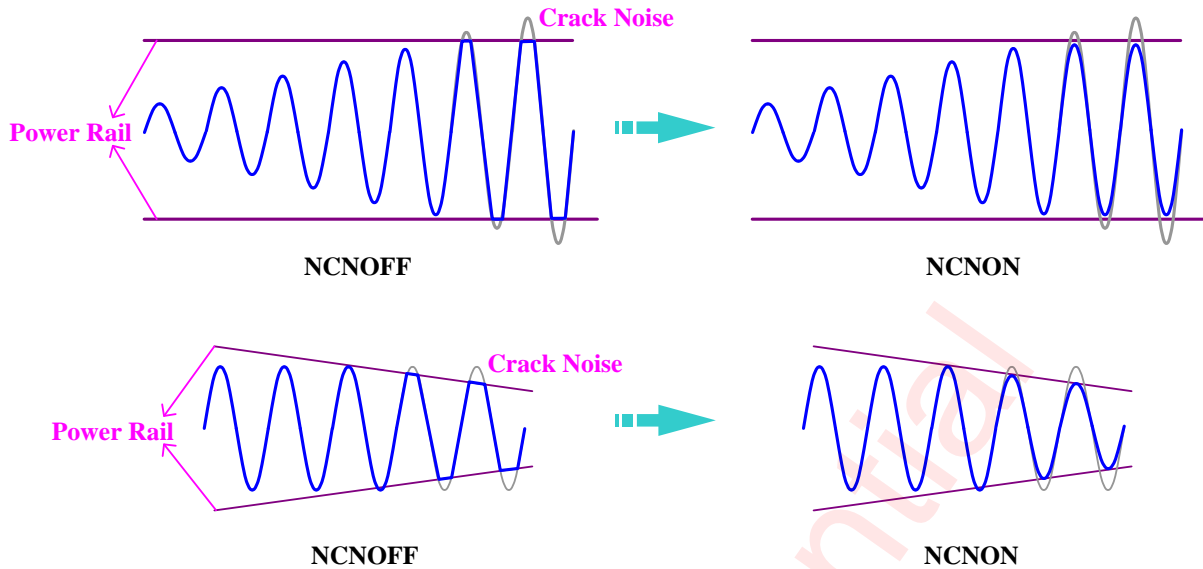

Figure 8 NCN Function Diagram

**Attack time**

Attack time is the time it takes for the gain to be reduced by 6dB once the audio signal exceeds the NCN threshold. Fast attack times allow the NCN to react quickly and prevent transients such as symbol crashes from being distorted. However, fast attack times can lead to volume pumping, where the gain reduction and release becomes noticeable, as the NCN cycles quickly. Slower attack times cause the NCN to ignore the fast transients, and instead act upon longer, louder passages. Selecting an attack time that is too slow can lead to increased distortion in the case of the No Clip function. Attack time is set 40ms in AW8733A.

**Release time**

Release time is the time it takes for the gain to return from 6dB to its normal level once the audio signal returns below the NCN threshold. A fast release time allows the NCN to react quickly to transients, preserving the original dynamics of the audio source. However, similar to a fast attack time, a fast release time contributes to volume pumping. A slow release time reduces the effect of volume pumping. Release time is set 1.2s in AW8733A.

**Filter-Free Modulation Scheme**

The AW8733A features a filter-free PWM architecture that reduces the LC filter of the traditional Class-D amplifier, increasing efficiency, reducing board area consumption and system cost.

**EEE**

The AW8733A features a unique Enhanced Emission Elimination (EEE) technology, that controls fast transition on the output, greatly reduces EMI over the full bandwidth.

**Pop-Click Suppression**

The AW8733A features unique timing control circuit, that comprehensively suppresses pop-click noise, eliminates audible transients on shutdown, wakeup, and power-up/down.

**Protection Function**

When a short-circuit occurs between VOP/VON pin and VDD/GND or VOP and VON, the over-current circuit shutdown the device, preventing the device from being damaged. When the condition is removed, the AW8733A reactivate itself. When the junction temperature is high, the over-temperature circuit shutdown the device. The circuit switches back to normal operation when the temperature decreases to safe levels.

awinic Confidential

## Applications Information

### External Input Resistor- $R_{ine}$ (Gain setting)

The AW8733A is a differential audio amplifier. The IC integrates two internal input resistors, which 30k $\Omega$  in mode1 and mode2, 5k $\Omega$  in mode3 and mode4. Take external input resistor  $R_{ine}$ =10k $\Omega$  for an example, gain setting as follows:

$$\text{Mode1: } A_V = \frac{160k\Omega}{R_{ine} + R_{ini}} = \frac{160k\Omega}{10k\Omega + 30k\Omega} = 4V/V$$

$$\text{Mode2: } A_V = \frac{240k\Omega}{R_{ine} + R_{ini}} = \frac{240k\Omega}{10k\Omega + 30k\Omega} = 6V/V$$

$$\text{Mode3: } A_V = \frac{240k\Omega}{R_{ine} + R_{ini}} = \frac{240k\Omega}{10k\Omega + 5k\Omega} = 16V/V$$

$$\text{Mode4: } A_V = \frac{360k\Omega}{R_{ine} + R_{ini}} = \frac{360k\Omega}{10k\Omega + 5k\Omega} = 24V/V$$

### Input Capacitor- $C_{in}$ (input high-pass cutoff frequency)

The input coupling capacitor blocks the DC voltage at the amplifier input terminal. The input capacitors and input resistors form a high-pass filter with the corner frequency:

$$f_H(-3dB) = \frac{1}{2 * \pi * R_{intotal} * C_{in}} \text{ (Hz)}$$

Setting the high-pass filter point high can block the 217Hz GSM noise coupled to inputs. Better matching of the input capacitors improves performance of the circuit and also helps to suppress pop-click noise.

Take typical application in Figure 2 as an example:

Mode1, Mode2:

$$f_H(-3dB) = \frac{1}{2 * \pi * R_{intotal} * C_{in}} \text{ (Hz)} = \frac{1}{2 * \pi * 40k\Omega * 22nF} \text{ (Hz)} = 182\text{Hz}$$

Mode3, Mode4:

$$f_H(-3dB) = \frac{1}{2 * \pi * R_{intotal} * C_{in}} \text{ (Hz)} = \frac{1}{2 * \pi * 15k\Omega * 22nF} \text{ (Hz)} = 485\text{Hz}$$

### Supply Decoupling Capacitor ( $C_S$ )

The AW8733A is a high-performance audio amplifier that requires adequate power supply decoupling. Place a low equivalent-series-resistance (ESR) ceramic capacitor, typically 0.1 $\mu$ F. This choice of capacitor and placement helps with higher frequency transients, spikes, or digital hash on the line. Additionally, placing this decoupling capacitor close to the AW8733A is important, as any parasitic resistance or inductance between the device and the capacitor causes efficiency loss. In addition to the



0.1 $\mu$ F ceramic capacitor, place a 4.7 $\mu$ F capacitor on the VBAT supply trace. This larger capacitor acts as a charge reservoir, providing energy faster than the board supply, thus helping to prevent any droop in the supply voltage.

### Flying Capacitor ( $C_F$ )

The value of the flying capacitor ( $C_F$ ) affects the load regulation and output resistance of the charge pump. A  $C_F$  value that is too small degrades the device's ability to provide sufficient current drive. Increasing the value of  $C_F$  improves load regulation and reduces the charge pump output resistance to an extent. A 4.7 $\mu$ F capacitor is recommended.

### Hold Capacitor ( $C_H$ )

The output capacitor value and ESR directly affect the ripple at PVDD. Increasing  $C_H$  reduces output ripple. Likewise, decreasing the ESR of  $C_H$  reduces both ripple and output resistance. A 4.7 $\mu$ F@10V capacitor is recommended.

### Optional Ferrite Bead Filter

The AW8733A passed FCC and CE radiated emissions with no ferrite chip beads and capacitors. Use ferrite chip beads and capacitors if device near the EMI sensitive circuits and/or there are long leads from amplifier to speaker, placed as close as possible to the output pin.

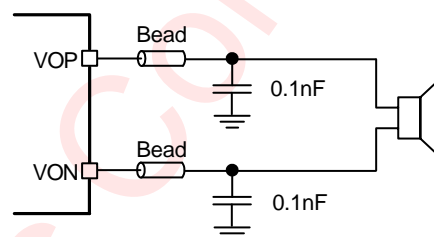
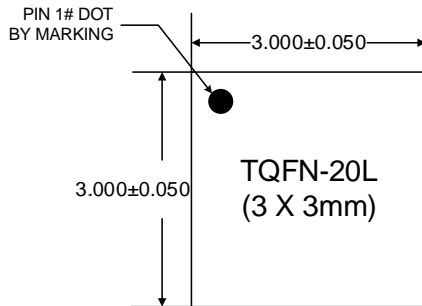
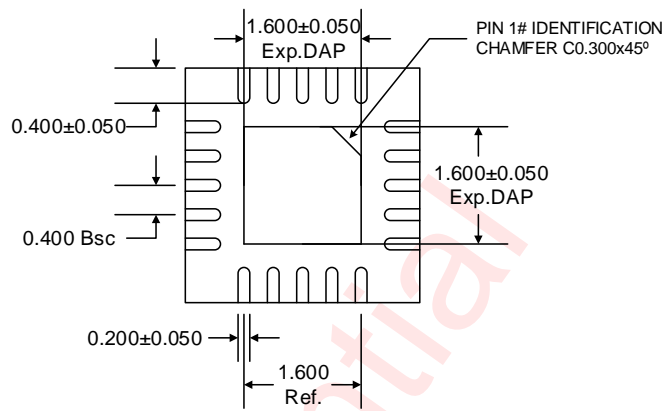

Figure 9 Ferrite Chip Bead and capacitor

## Package Description



TOP VIEW



BOTTOM VIEW

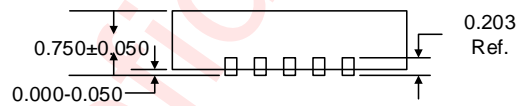

SIDE VIEW

**VERSION INFORMATION**

Version	Date	Description
V1.0	2012-06	AW8737A datasheet V1.0
V1.1	2020-04-24	<ol style="list-style-type: none"><li>1. Update both <math>C_S</math> and <math>C_H</math>; and change it from 10uF to 4.7uF</li><li>2. Update the PSRR value and the relative expression</li><li>3. Update the PSRR characteristics curve</li><li>4. Change the capacitance from 1nF to 0.1nF in Figure 9</li></ol>

## DISCLAIMER

Information in this document is believed to be accurate and reliable. However, Shanghai AWINIC Technology Co., Ltd (AWINIC Technology) does not give any representations or warranties, expressed or implied, as to the accuracy or completeness of such information and shall have no liability for the consequences of use of such information.

AWINIC Technology reserves the right to make changes to information published in this document, including without limitation specifications and product descriptions, at any time and without notice. Customers shall obtain the latest relevant information before placing orders and shall verify that such information is current and complete. This document supersedes and replaces all information supplied prior to the publication hereof.

AWINIC Technology products are not designed, authorized or warranted to be suitable for use in medical, military, aircraft, space or life support equipment, nor in applications where failure or malfunction of an AWINIC Technology product can reasonably be expected to result in personal injury, death or severe property or environmental damage. AWINIC Technology accepts no liability for inclusion and/or use of AWINIC Technology products in such equipment or applications and therefore such inclusion and/or use is at the customer's own risk.

Applications that are described herein for any of these products are for illustrative purposes only. AWINIC Technology makes no representation or warranty that such applications will be suitable for the specified use without further testing or modification.

All products are sold subject to the general terms and conditions of commercial sale supplied at the time of order acknowledgement.

Nothing in this document may be interpreted or construed as an offer to sell products that is open for acceptance or the grant, conveyance or implication of any license under any copyrights, patents or other industrial or intellectual property rights.

Reproduction of AWINIC information in AWINIC data books or data sheets is permissible only if reproduction is without alteration and is accompanied by all associated warranties, conditions, limitations, and notices. AWINIC is not responsible or liable for such altered documentation. Information of third parties may be subject to additional restrictions.

Resale of AWINIC components or services with statements different from or beyond the parameters stated by AWINIC for that component or service voids all express and any implied warranties for the associated AWINIC component or service and is an unfair and deceptive business practice. AWINIC is not responsible or liable for any such statements.