

- ALC256 0
- CX1180 1
- CX11970 2
- ALC897 3
- CX20632 4

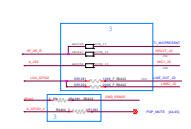

45 AUDIO IO

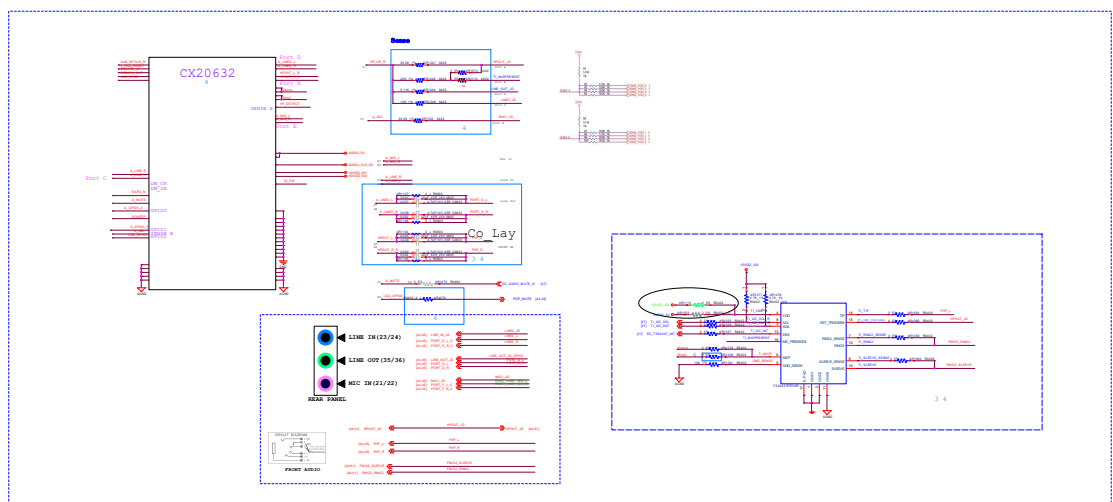
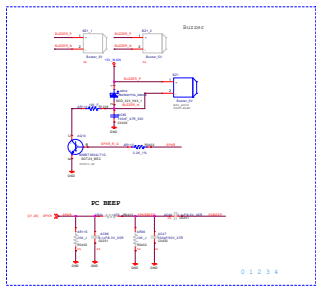
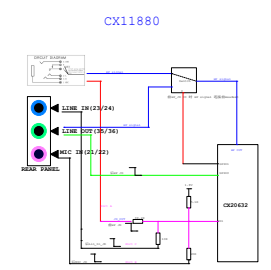
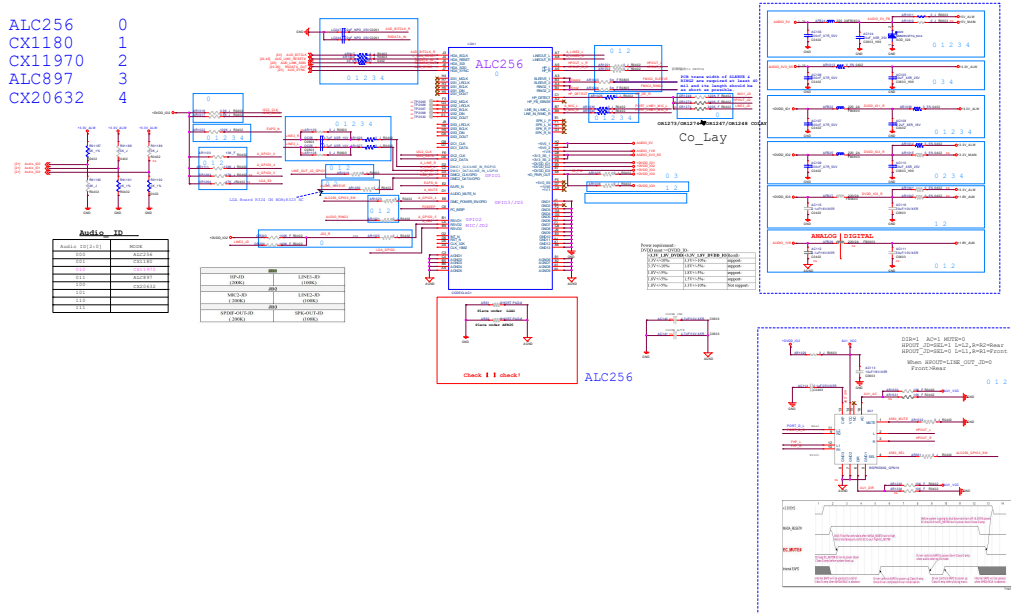
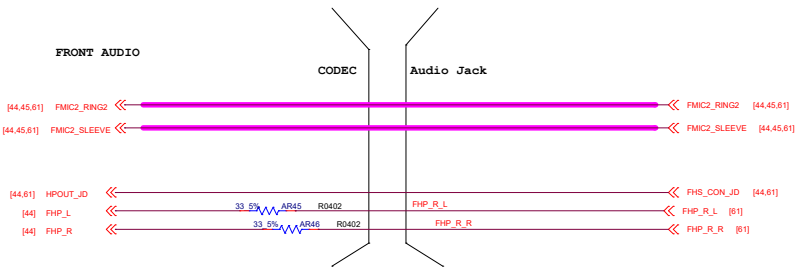
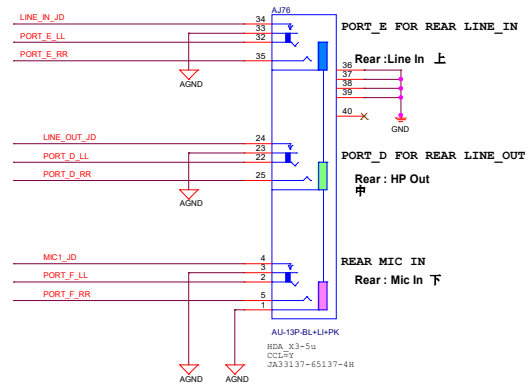
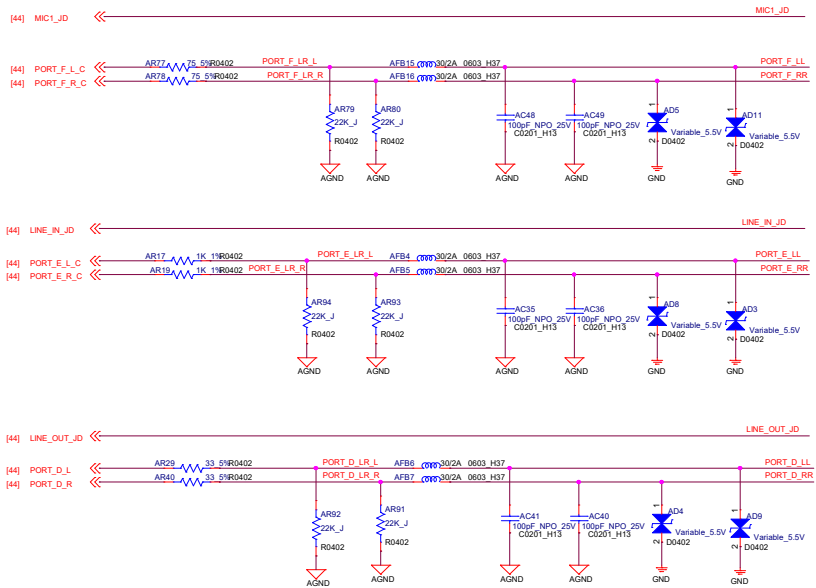

状态	耳机制式	GPIO A 控制sleeve	GPIO B控制Ring
A. 闲置状态: 耳机插入耳机, 耳机音量按钮 按到耳机音量按钮(耳机音量按钮的大按钮)		L	L
B. 插入耳机到线序检测完成阶段: 耳机音量按钮, 耳机音量按钮 (耳机音量按钮, 耳机音量按钮) (耳机音量按钮, 耳机音量按钮)	默认耳机	L延时100ms 状态变为H	L
C. 线序检测完成且耳机工作正常: 耳机音量按钮音量按钮音量按钮 音量按钮音量按钮音量按钮 音量按钮音量按钮音量按钮 音量按钮音量按钮音量按钮	耳机	L	H
	耳机	H	L
	三段式	L	L
D. 拔出耳机恢复闲置状态:		L	L

De-pop circuit

