

This is a proprietary information of Nanhua Electronics Co.,Ltd.No duplication in whole or partially with any mean is allowed,unless such action is authorized by a written statement from Nanhua.本设计属南华机电智慧财产，非本公司授权禁止对外揭露或影印本设计图样。

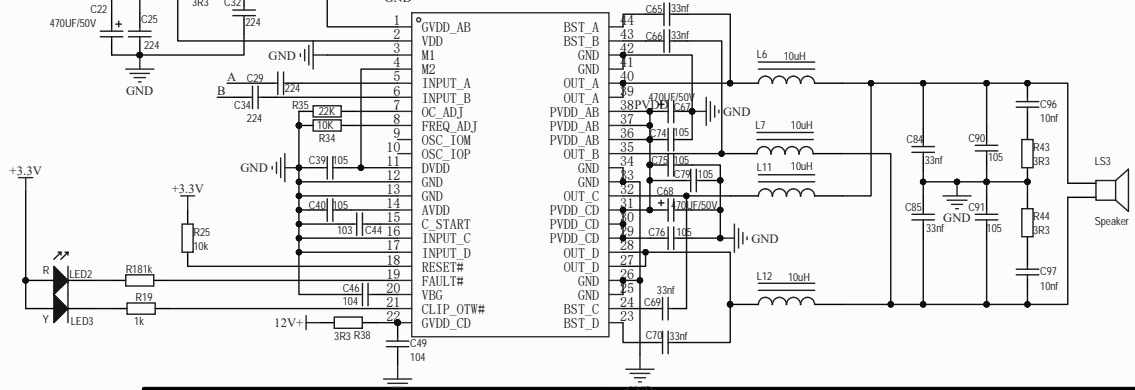
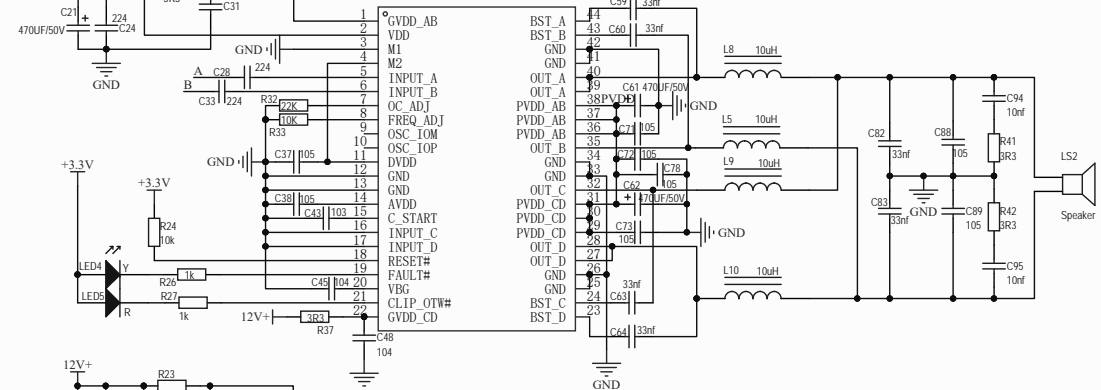
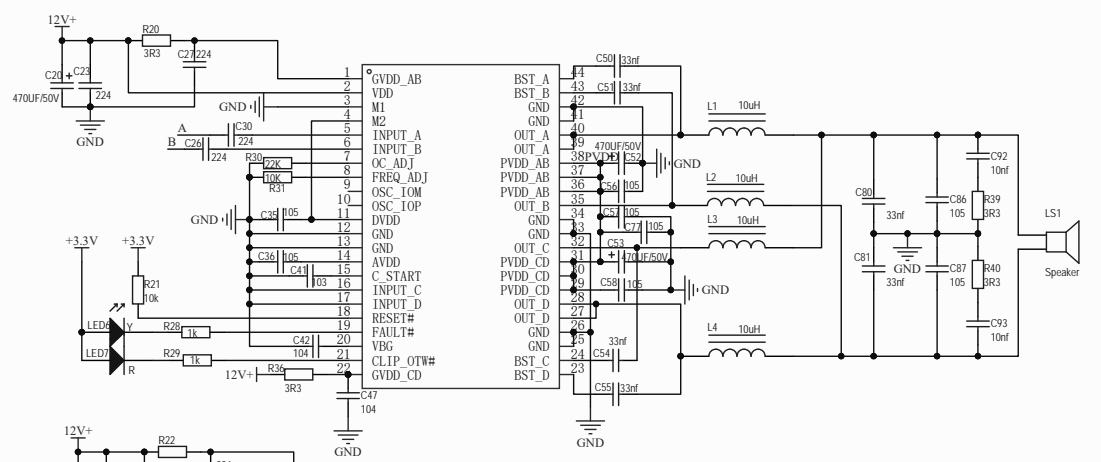
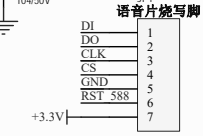
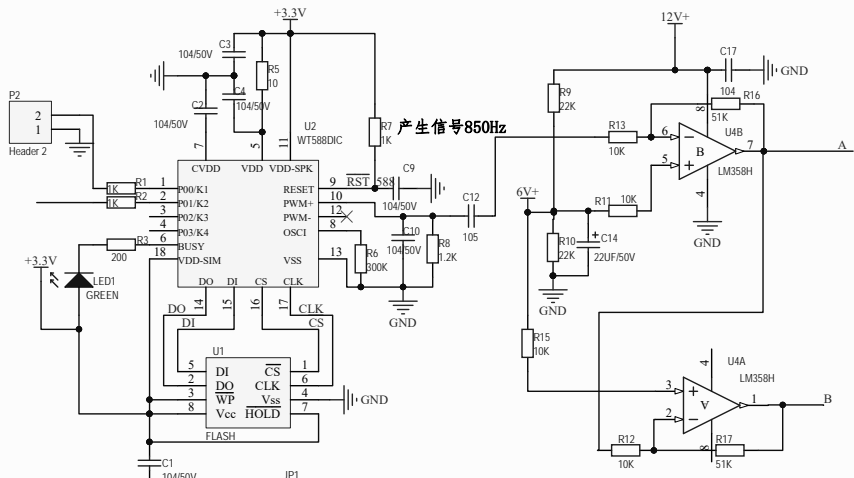
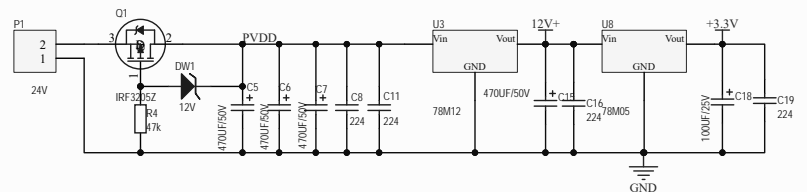

| | | | | | | | |
|-------------------|---------------------|---------------|------------|-----------------|------|------------------|----|
| 产品型号 MODEL NO. | | Fog Signa | | 图名 PART NAME | | Fog Signal原理图 | |
| 产品名称 NAME | | | | 图号 DWG NO. | | NHE-ETH010-S1 | |
| 设计 DESIGN | 汤响 | 日期 DATE | 20250520 | 版本 VER. | V1.1 | 图面 PAPER SIZE | A3 |
| 校对 CHECK | | 共 1 页 / 第 1 页 | | | | | |
| 位置 LOCATION | 更改内容 DESCRIPTION | 更改者 NAME | 版本 VER. | | | | |