

# RK3308 Part-H

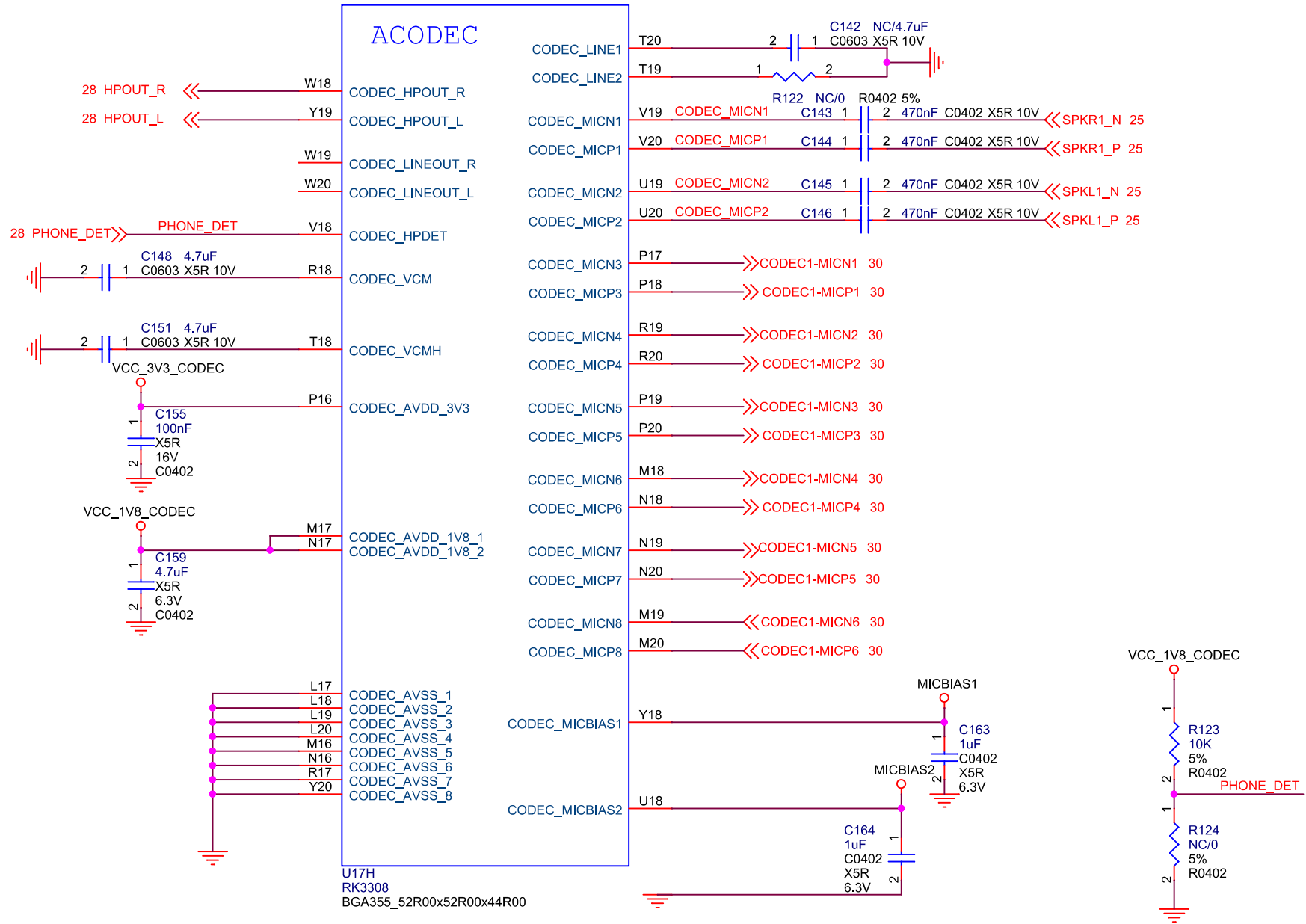

<i>ByteDance</i>			
Title		V2	
Size	Document Number	Rev	
A4	<Doc>	<RevCode>	
Date:	Sunday, September 20, 2020	Sheet	19 of 31

# RK3308 Part-J

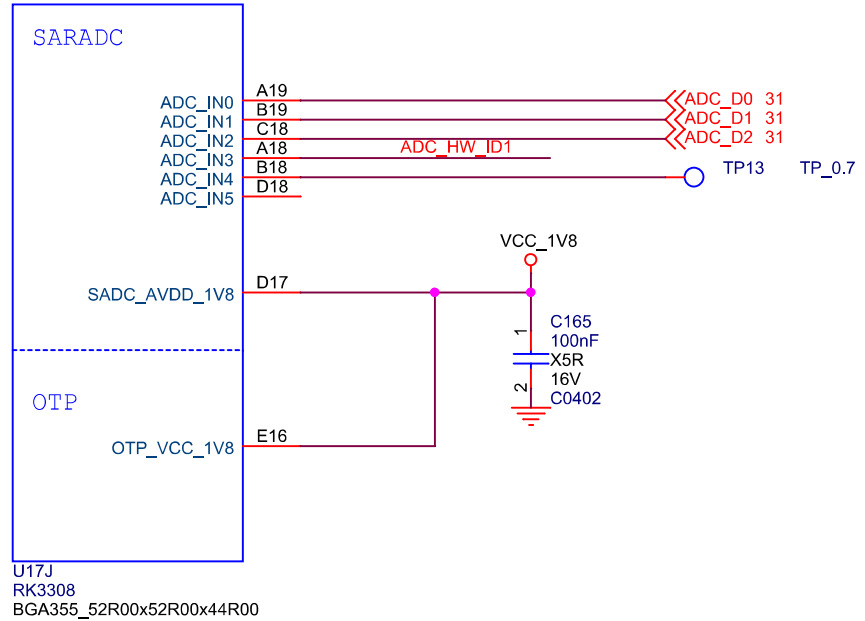

U17J  
RK3308  
BGA355\_52R00x52R00x44R00

## HW ID

ADC_HW_ID	Pull-up Resistance	Pull-down Resistance	ADC Value
BOM0	51K	DNP	1024
BOM1	51K	51K	512
BOM2	51K	22K	308

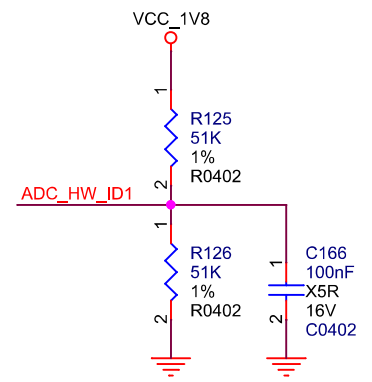



# DDR3 1x16bit

Remind: Refer to the latest AVL for parts selection.

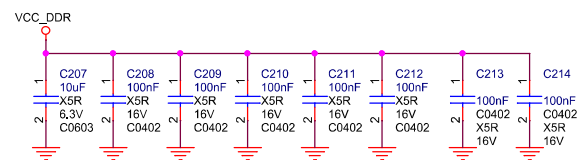
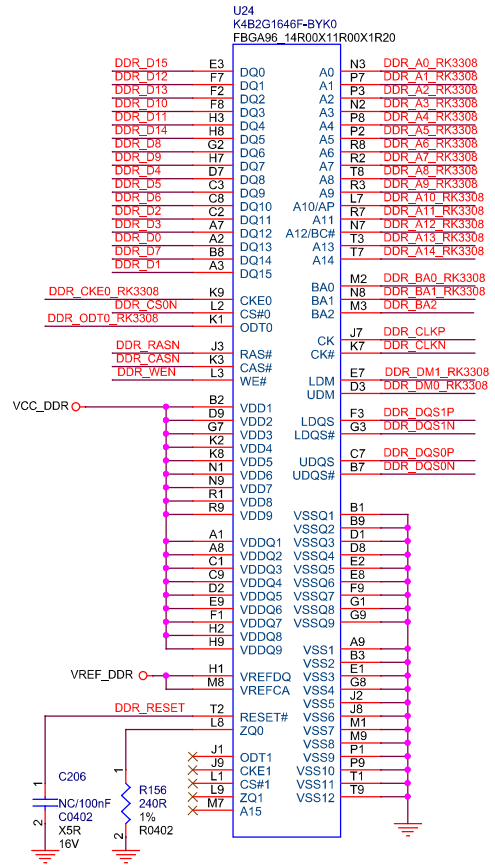
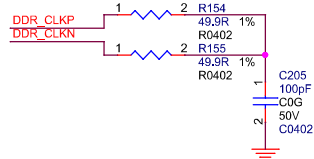
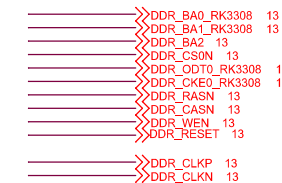
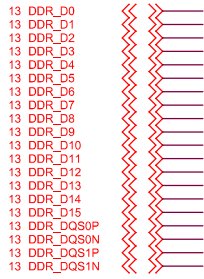

Note: All the Power filter capacitors should be placed close to the power pins of DDR3

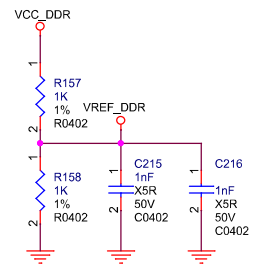

# SPI Nor Flash

Remind: Refer to the latest AVL for parts selection.

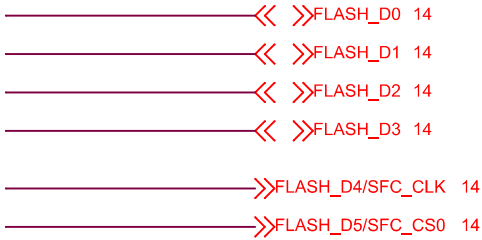
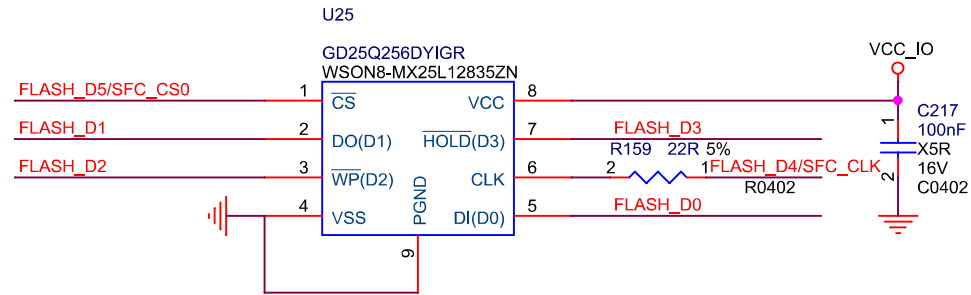

Remind: Short two TP points to Enter MaskRom.

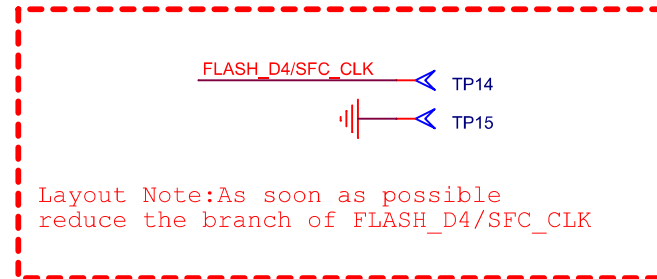

Note:  
For MicArray Algorithm Use Only

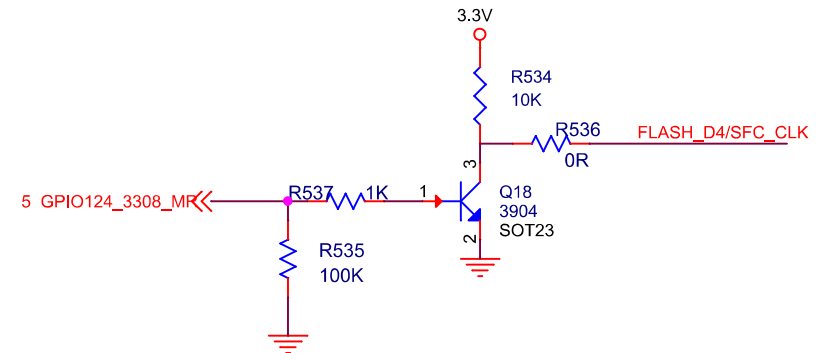
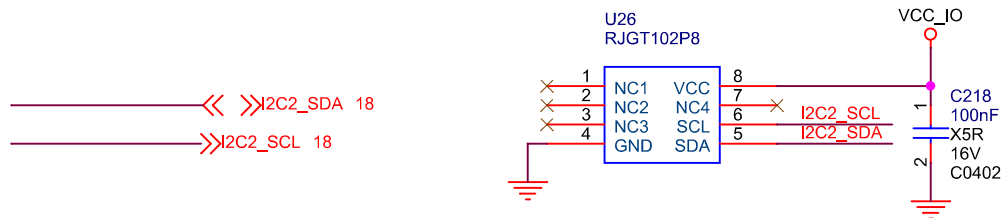

support external trigger into maskroom

<i>ByteDance</i>		
Title V2		
Size A4	Document Number <Doc>	Rev <Rev Code>
Date: Sunday, September 20, 2020	Sheet 23	of 31

Remind: Loopback from Digital Amplifier  
Get PCM Data at Post-Process Point

Note:  
Device ID 7bit  
due to ERROR pin state during power up

AMP_ERROR	Address of I2C
15K	R0101101

**Power**

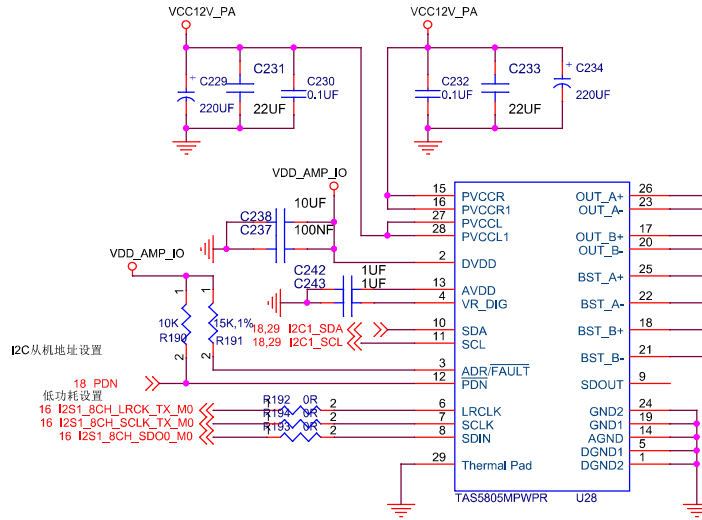
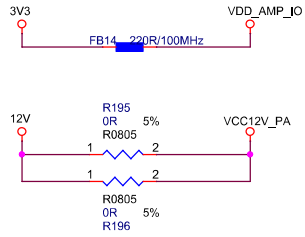

Layout Note: Place close to speaker jack.

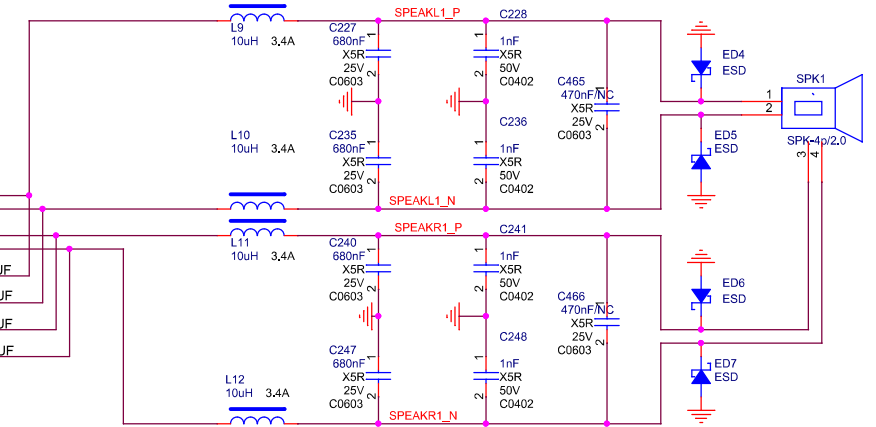

**NOTE ECHO**

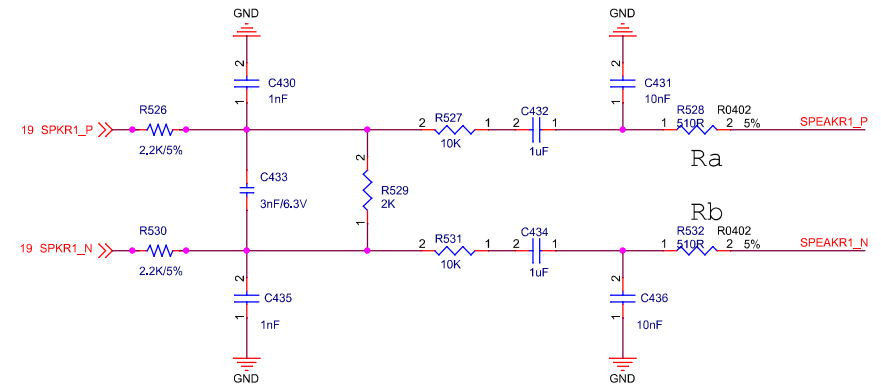
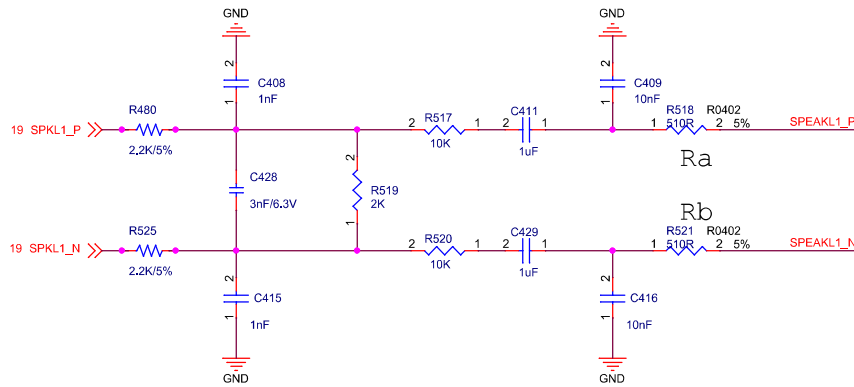

# Music In

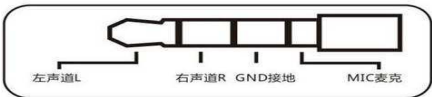
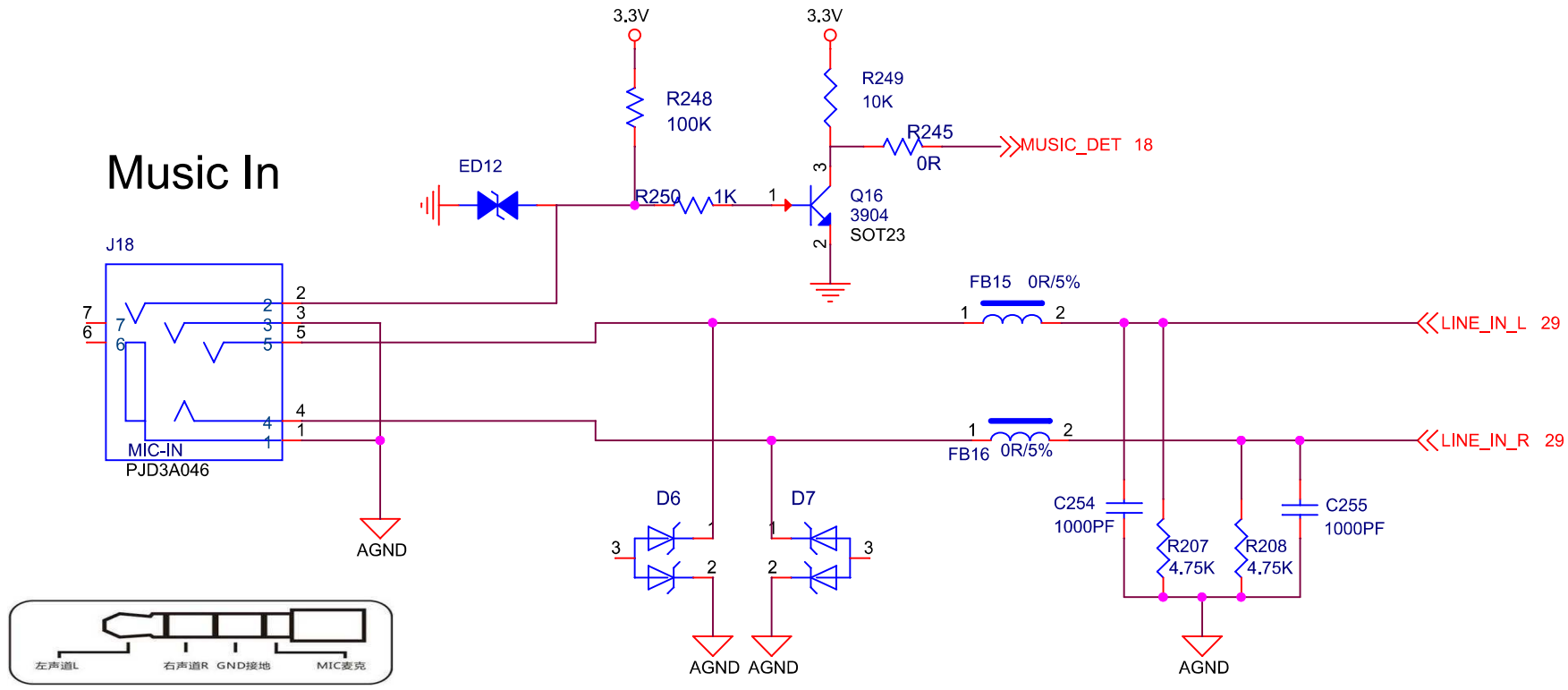

<i>ByteDance</i>			
Title		V2	
Size	Document Number	Rev	
Custom	<Doc>	<RevCode>	
Date:	Sunday, September 20, 2020	Sheet	26 of 31

# MIC IN

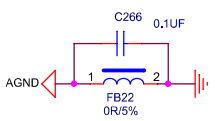
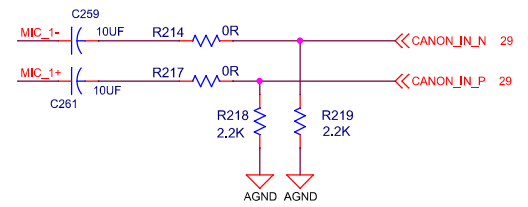
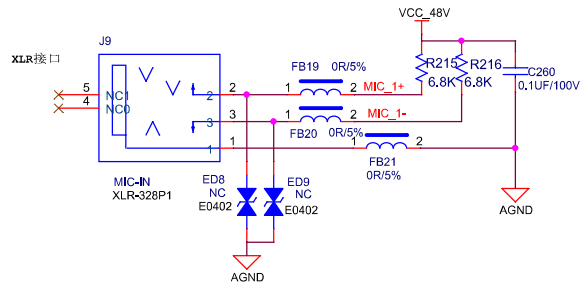

# POWER SUPPLY:

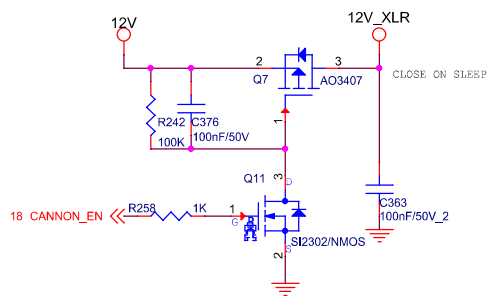
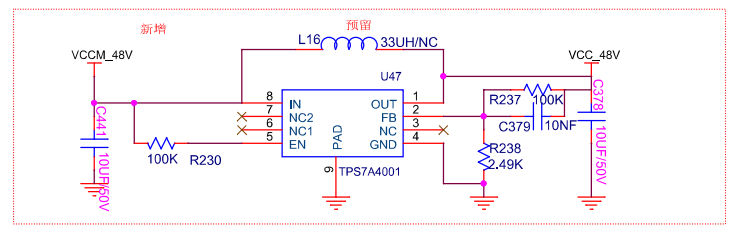
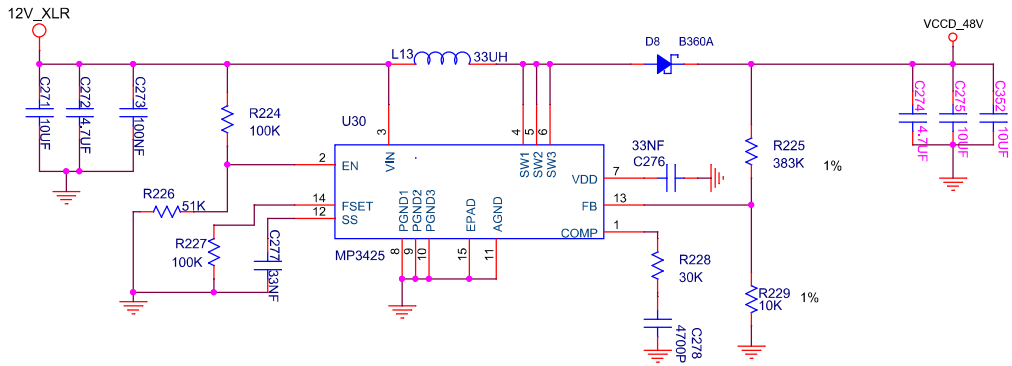

Title			V2		
Size	A3	Document Number	AUDIO CODEC		
Date:	Sunday, September 20, 2020	Sheet	27	of	31



# Headphone/MIC

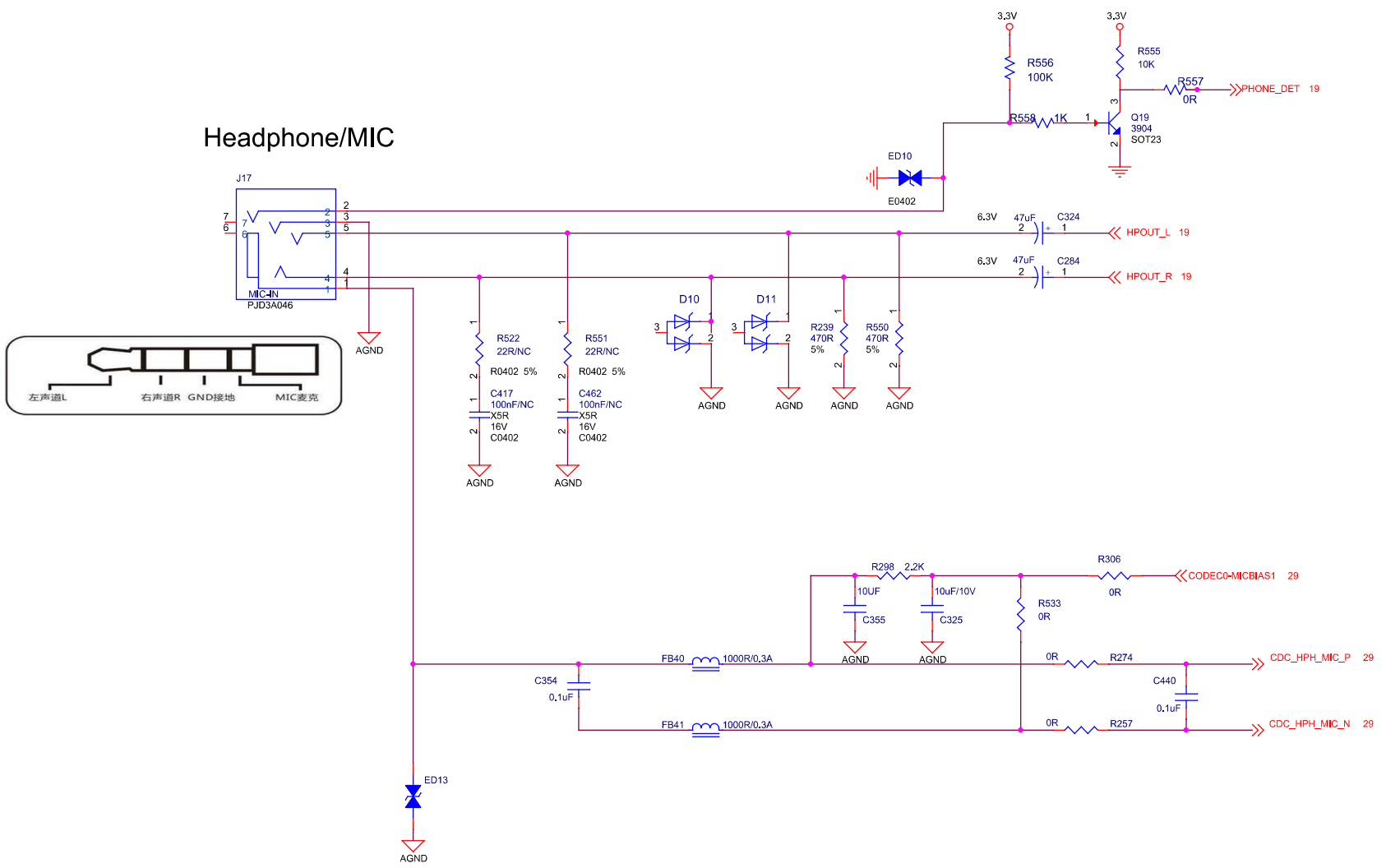

<i>ByteDance</i>		
Title V2		
Size A3	Document Number AUDIO CODEC	Rev 1.0
Date: Monday, September 21, 2020	Sheet 28 of 31	

# AUDIO0 IN

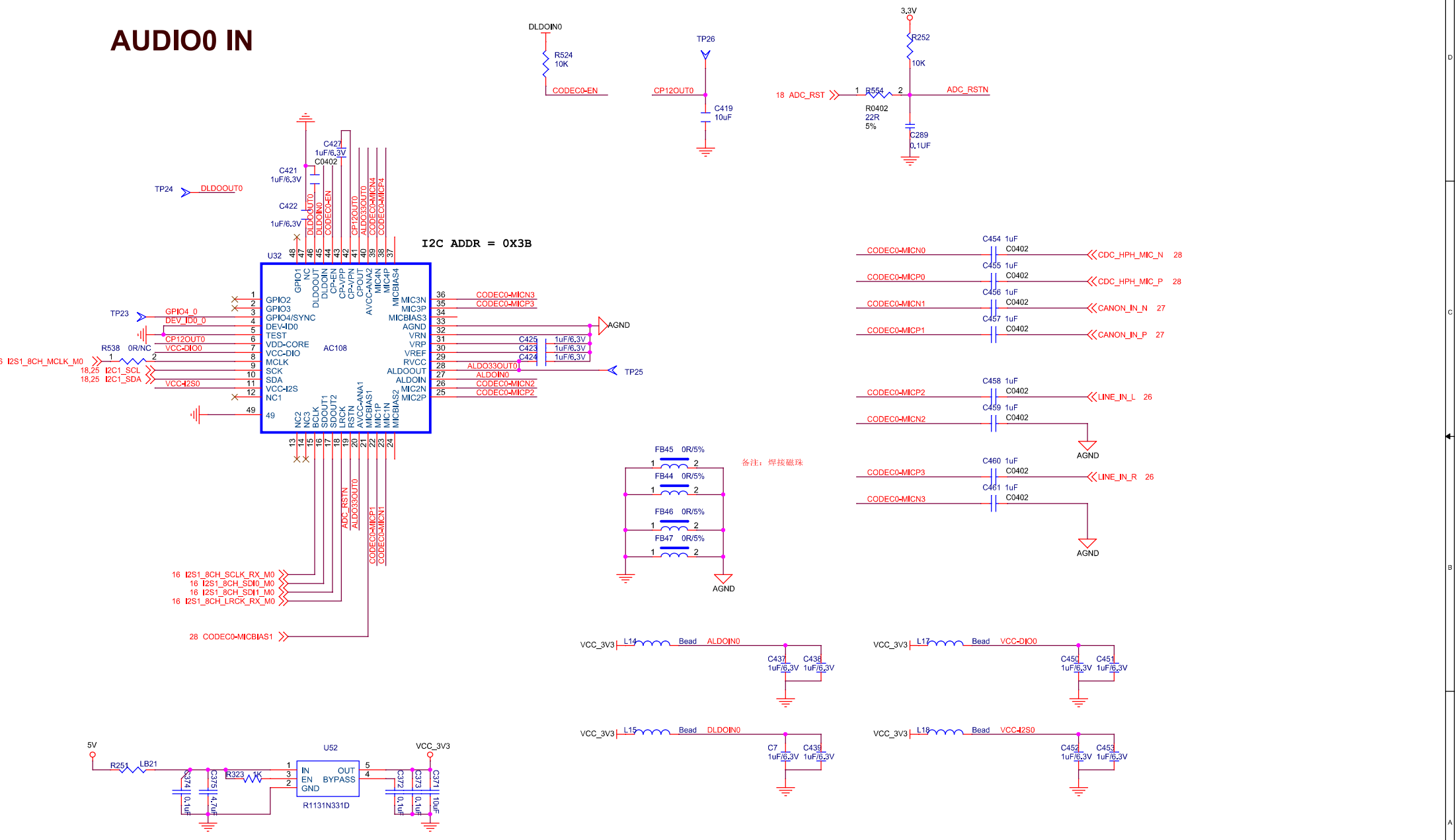

备注：焊接磁珠

<i>ByteDance</i>		
Title V2		
Size A3	Document Number SYSTEM POWER	Rev 1.0
Date: Sunday, September 20, 2020	Sheet 29	of 31

# 6 MIC ARRAY

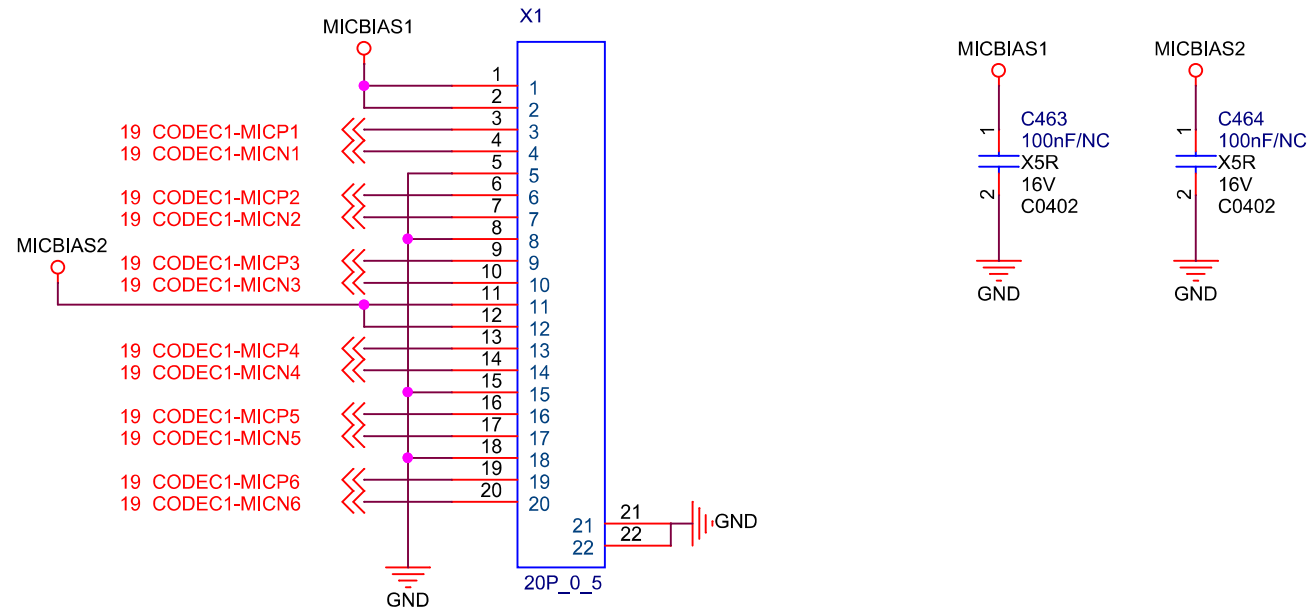

<i>ByteDance</i>		
Title V2		
Size A	Document Number <Doc>	Rev <RevCode>
Date:	Sunday, September 20, 2020	Sheet 30 of 31