

Ethos[®]

Product Features

130 nanometer CMOS DSP Engine - more computations per second

Third-Generation Reliant™ Adaptive Feedback Cancelling (AFC)

- Faster adapting speed means less squeaking even when things move around in the ear
- More Added Stable Gain

Improved Layered Noise Reduction™

- Twelve noise reduction bands
- A more aggressive 17 dB cut setting available for extreme noise situations
- Extended frequency range of action to 7750 Hz—more useful for open fittings
- Soft-squelch reduces low-level noise, including microphone noise

Eight-channel Wide-Dynamic-Range Compression (WDRC) with Dynamic Contrast Detection™

- Three-mode adaptive time constants to optimize WDRC performance in critical environments
- Compression ratio and the threshold adjustable independently in each channel
- Maximum Power Output compression limiting is also adjustable independently in each channel

Adaptive Directional Microphone Processing

- Automatically switches from Omni to Directional when environment changes
- Eliminates extra 'directional' user program and need for user interaction

Event Data Logging

- Elapsed-time clock will record the time amplifier has been operating since it was made
- Events are recorded and 'time stamped'
- User events: power-on events, volume control change, program change, low battery events
- All events will be logged in a buffer available to the fitting system
- Fitting system can present the data to help the dispenser understand usage patterns

Digital Random Noise Generator

- Digital generation of random noise gives a clean noise sound for masking use
- Noise is injected at the input, so it can be shaped by existing EQ gain adjusters
- Can be used in mixed-move applications: one for masking, and another for hearing instrument use

Digital Volume Control Compatible

- Two-pin Digital Volume Control Port
- Start-Up volume control position is programmable
- Use pushbutton switches or a digital rotary control
- Analog Volume Control Mode also available

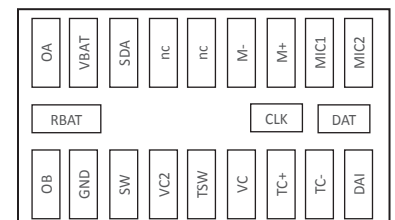

Reflowable PCB Package

FEATURE DESCRIPTIONS

Automatic Telecoil and MTO Switching

A dedicated switching pad is available for applications of automatic telecoil (auto-tcoil) switching or MTO switching. This mode is used by attaching a magnetic switch or mechanical switch from the telecoil switch (TSW) pad to GND. By programming, the 'auto-tcoil' mode is activated and the auto-tcoil program is designated by setting the parameter coilPGM. In the designated auto-tcoil program, the parameters are set to activate the telecoil and adjust other parameters to the desired telecoil performance. When the TSW pad is pulled to GND, the amplifier switches to the program set by coilPGM (typically program 5) and stays there until the TSW pad is open. Then the amplifier reverts to the user memory that was active just before TSW was grounded.

Band Gain Equalizers

Twelve band gain adjusters - equalizers - are available to precisely match fitting targets. Band 1 covers the frequency 250 Hz and below. Bands 2-8 are 500 Hz wide. Bands 9-12 are 1000 Hz wide. Center frequencies of bands are: ~100 Hz, 500 Hz, 1000 Hz, 1500 Hz, 2000 Hz, 2500 Hz, 3000 Hz, 3500 Hz, 4250 Hz, 5250 Hz, 6250 Hz, 7250 Hz. Each band has adjustable gain in 2 dB increments from 0 dB to -40 dB.

Event Data Logging

The data logging feature stores information associated with the following four events: Startup, VC, PB, and Low Battery Warning. This allows monitoring of such things as daily usage, battery life, number of times user adjusts VC, or adjusts the active program. A definition of the Events and their associated status is as follows:

Startup Event = 1:

The startup event has 2 to 24 bit status words associated with it and it occurs whenever the device is powered on. The two words are a 24 bit Event Status and a 24 bit real time clock using this format:

Event status format: EEEE EEEP PVVV VV00 0000 0000

E = 7 bit event code Startup event code = 1

P = 2 bit Active program setting

V = 5 bit VC position setting

Real Time Clock: 24 bit counter where each count is 10 minutes

VC event = 2,

PB event = 3,

Low Battery Warning event = 4:

All these events have one 24 bit status word associated with them

Event status format: EEEE EEEP PVVV VVCC CCCC CCCC

E = 7 bit event code

P = 2 bit Active program setting

V = 5 bit VC position setting

C = 10 least significant bits of the real time clock

Input Modes

There are four single input modes: MIC1, MIC2, TC+, and DAI. When one of these modes is activated, the input pad by that name is active, and all other inputs are turned off. Inputs MIC1, MIC2 and TC+ have internal AC coupling capacitors. Input DAI is DC coupled and usually requires

an external AC coupling capacitor. One input mode is for the Digital Noise Generator source. There are three summing modes available: 'MIC1 + DAI', 'MIC1 + TC+', and 'MIC1 + Noise Generator'. There are 3 fixed directional pattern modes that use the signals from microphones connected to inputs MIC1 and MIC2: Fixed Directional - Cardioid, Fixed Directional - Supercardioid, Fixed Directional - Hypercardioid. There are 3 adaptive directional pattern modes that use the signals from microphones connected to inputs MIC1 and MIC2: Adaptive Directional - Cardioid, Adaptive Directional - Supercardioid, Adaptive Directional - Hypercardioid.

In-situ Tone Generator

The amplifier comes with a programmable tone generator that can be used for in-situ validation of the hearing instrument fitting. The programmable parameters are frequency, level and duration of the generated tone signal. The eight frequencies options available are: 250 Hz, 500 Hz, 1 kHz, 1.5 kHz, 2 kHz, 3 kHz, 4 kHz, 6 kHz. The input referred level of the generated tone can be adjusted between 20 dB SPL and 90 dB SPL in 5 dB increments. The duration of the tone being generated is set by providing a count which sets the signal duration as follows: duration (sec) = .5 ms x count. Count is an integer between 1 and 32767.

Ex: Count needed to get 500 ms beep is $500 \text{ ms} / .5 \text{ ms} = 1000$

Layered Noise Reduction™ (LNR)

Our unique version of noise reduction acts to remove noise in between speech syllables as well as to lower general background noise from the environment. All layers respond to noise of all intensities so it replaces the function of low-level expansion. The LNR function can be set to the following settings: off, low, medium, high. Additional information on this feature can be found in the IntriCon technology white paper titled "Understanding Layered Noise Reduction" (available on the IntriCon website or from your IntriCon sales representative).

Low Battery Warning

When the battery voltage nears the end of life, the amplifier will detect this condition and provide a low battery warning signal. The first warnings begin when the average battery voltage falls below 1.05V. At this time, the amplifier emits three sets of double beeps every ten minutes. When the average battery voltage falls lower than 0.95V, the amplifier issues six sets of double beeps, and then shuts down the audio output of the hearing instrument. The frequency and loudness of the beep tones are programmed as set forth in the section 'Tone Adjustments.' Low battery warning can be disabled via software.

Manufacturer's Data Area (Scratch-Pad Memory)

Ten memory locations are provided to store any hearing instrument and fitting system information that is desired. Each location is 16 bits long. Typical stored items are model code, serial number, calibration constants, version numbers, etc.

FEATURE DESCRIPTIONS

Manufacturer's ID

An 8-bit memory location is reserved to store a code called Manf_ID. This code is assigned by IntriCon to each manufacturer that requests a unique code. This can be used to identify hearing instruments of a given manufacturer from others. IntriCon's engineering software called "Slider" will not read and program amplifiers with the Manf_ID set to values other than zero, unless the code has been unlocked using the proper key provided by IntriCon. This prevents undesired changing of hearing instrument parameters.

Output Limiting

The maximum power output (MPO) of the amplifier can be limited using the compression limiter. This method of output control does not create harmonic distortion like peak clipping. In each of 8 compression channels, the MPO can be programmed to settings of Off, 0 dB, -2 dB, -4 dB, -6 dB, -8 dB, -10 dB, -12 dB, -14 dB, -16 dB, -18 dB, -20 dB, -22 dB, -24 dB, -26 dB, and -28 dB (relative to no limiting). The output level will not be affected by the volume control setting, since the limiter is placed right before the output stage and after the VC block.

Overall Gain

The parameter for overall gain of the amplifier is also called Matrix Gain. It is adjustable in 1 dB steps from 0 dB to -47 dB. Use this parameter to set to set the overall gain of an application, and then use the band gain adjusters to handle frequency shaping. The user VC adjustment will reduce the gain downward starting at the setting of matrix gain. It is important to remember that some values of matrix gain will be too high for a particular application, and the fitting system should insure that these high values are not available at fitting time.

Power-on Options

Two parameters are available to control how the amplifier behaves during power-up. The Power-on Delay controls the length of time the amplifier is muted after the power is applied. It is programmable to values of 1, 5, 10 and 15 seconds. The Power-on Level controls how loud the amplifier is after power on. Parameter values are: -60 dB, -30 dB, -20 dB, -10 dB.

Preampifiers

There are two adjustable preamplifiers to handle the four input pads. Preampifier 0 handles the inputs MIC1, MIC2, DAI and TC+. Preamp 1 is used when combined input features, such as directional, are selected. Each preamp gain is programmable to the settings 0 dB, 12 dB, 15 dB, 18 dB, 21 dB, 24 dB, 27 dB, and 30 dB.

Program Switch Tones

When this feature is enabled by programming, the amplifier will emit beeps every time the SW pad is connected to ground. The number of beeps duplicates the program number being switched into, i.e. when moving into program 2, two beeps will be heard. When moving into program 4, four beeps will be heard. The frequency and loudness of the beep tones are programmed as set forth in the section 'Tone Adjustments.'

Random Noise Generator

The amplifier has an internal random noise generator that creates a flat spectrum pseudorandom digital noise sequence. The noise signal is injected at the front end of the amplifier before any of the signal processing. The amplitude of the noise is programmable to values of 30 dB SPL to 65 dB SPL (input referred) in 5 dB increments. Using the Input Selector parameter, one can set up the noise generator to operate optionally in any of the user programs. For example, Program 1 could be set up with MIC1 active as a hearing instrument program. Program 2 could be set to activate the noise generator as a tinnitus masking program.

Reliant™ Adaptive Feedback Canceller (AFC)

Our third-generation adaptive feedback canceller in this amplifier uses unique adaptive filtering technology to cancel feedback. This technique is also called phase cancellation. It features faster adapting time, higher added stable gain, and better entrainment resistance. Entrainment is the tendency of a feedback canceller to become confused by tonal sounds. This can cause false whistling and squeaks. The anti-entrainment functions acts to prevent problems caused by single tones, multiple tones, and loud complex sounds. The AFC is effective for feedback problems occurring in the frequency range of 750 Hz to 6750 Hz. The AFC can be enabled or disabled separately in each user memory by programming.

SDA Programming Port

Communication to and from the amplifier is by means of the so-called SDA port. This port implements a proprietary bidirectional communication protocol with data and clock on the same line. Low-level PC-to-amplifier communication is handled by a dynamic-linked library ethos.dll provided by IntriCon. This driver supports the Hi-Pro interface unit, as well as the eMiniTec and NOAHLink.

Contact IntriCon for the latest support information, or check our website at www.intricon.com.

Tone Adjustments

The tones used for program switching and low battery warning are created in a tone generator. The tones can be injected either at the input end of the amplifier or at the output end, depending on programming of the 'tone_reference' parameter. The value 0 indicates input-injected tones, and the value 1 indicates output-injected tones. Available frequency settings are 500 Hz, 1000 Hz, 1500 Hz, and 2000 Hz. Available loudness settings are 60 dB SPL, 66 dB SPL, 72 dB SPL, and 78 dB SPL (input referred) when injected at the input, and 85 dB SPL, 90 dB SPL, 95 dB SPL, and 100 dB SPL (output referred) when injected at the output.

FEATURE DESCRIPTIONS

User Program Memory

As many as five user memories are available to an application. Up to four memories are available by selecting the value of the parameter “number_of_programs” by programming to 1-4. A fifth user memory can be added by activating the auto-tcoil function, and defining the auto-tcoil memory to be 5. Each of the user memories is a unique set of audio parameters. All of these parameters change when the user changes memory. The program change is accomplished by grounding the switch (SW) pad of the amplifier. There are two modes for this switch function. The static mode allows changes from Program 1 to Program 2 only. When the switch pad is grounded, the user Program 1 is active. When the SW pad is open, user Program 2 is active. In the momentary mode, every time the SW pad is grounded, the user program is incremented, until the top program is active. The next SW grounding event causes the user program to return to Program 1. Program switch tones will sound if this feature is enabled (see section ‘Program Switch Tones’).

Volume Control (VC) Function

A user VC can be connected to this amplifier, and the function can be configured to match the application. By programming, the VC can be set to digital mode, analog mode or disabled. The range of the VC is programmable to the settings 50 dB, 40 dB, 30 dB, 20 dB, 10 dB. To create an analog volume control, a 100 kohm linear-taper VC (such as IntriCon models 11, 12, 14, 25, 26, and 35) is wired with the center terminal to the VC pad, and the ends of the VC are wired to M+ and GND respectively. The VC mode should be set to analog. To create a digital volume control, there are 2 options: a digital volume control wheel (which can be connected) or 2 pushbutton switches. See the applications page for wiring diagrams for this option. The VC mode should be set to digital.

Wide Dynamic Range Compression (WDRC) with Dynamic Contrast Detection™

The Ethos amplifier uses unique IntriCon technology called Dynamic Contrast Detection in an 8-channel WDRC configuration. The technology is described in detail in the technology white paper titled Two-Channel WDRC with Dynamic Contrast Detection (available on the IntriCon web site, or from your IntriCon sales representative). Compression thresholds settings for channels are 40 dB SPL, 45 dB SPL, 50 dB SPL, 55 dB SPL, 60 dB SPL, 65 dB SPL, 70 dB SPL input- referred. Compression ratios settings of each channel are 1:1, 1.05:1, 1.11:1, 1.18:1, 1.25:1, 1.33:1, 1.43:1, 1.54:1, 1.67:1, 1.82:1, 2:1, 2.22:1, 2.5:1, 2.86:1, 3.33:1, and 4:1. Time constants settings are described in the technology white paper mentioned above. Channel crossover frequencies are at 250 Hz, 750 Hz, 1250 Hz, 1750 Hz, 2750 Hz, 3750 Hz and 5500 Hz.

APPLICATIONS

Ethos® Amplifier Hybrid

Part Number 92950-0009

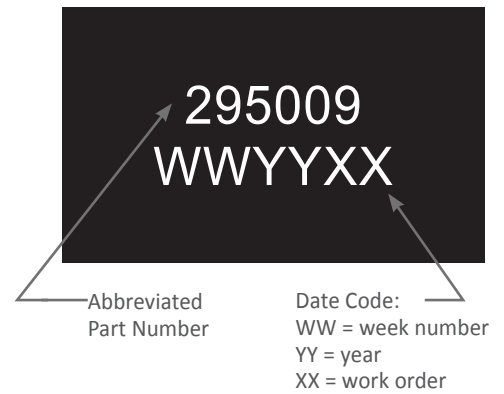
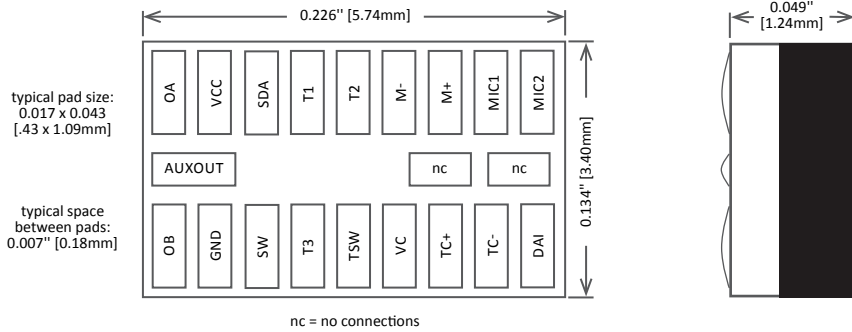

Ethos® Mini Amplifier Hybrid

Part Number 92591-0009

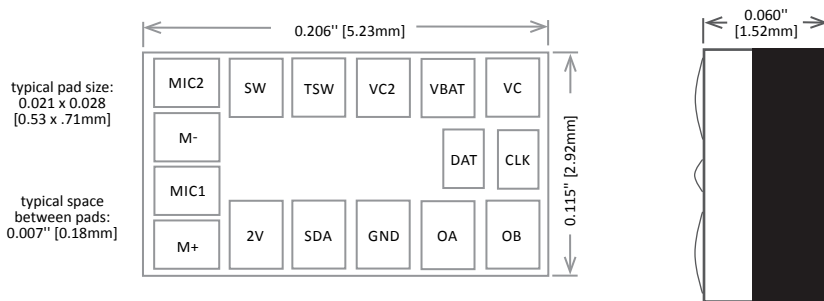

Note: Ethos Mini Hybrid is non-reflowable.

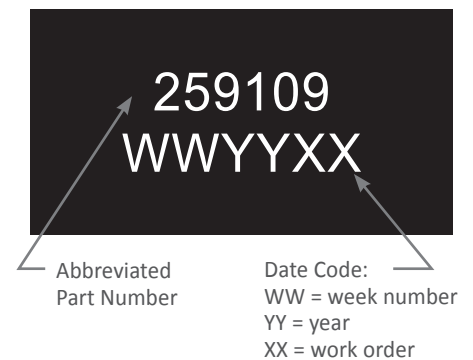

Wiring Schematic Showing Full Features

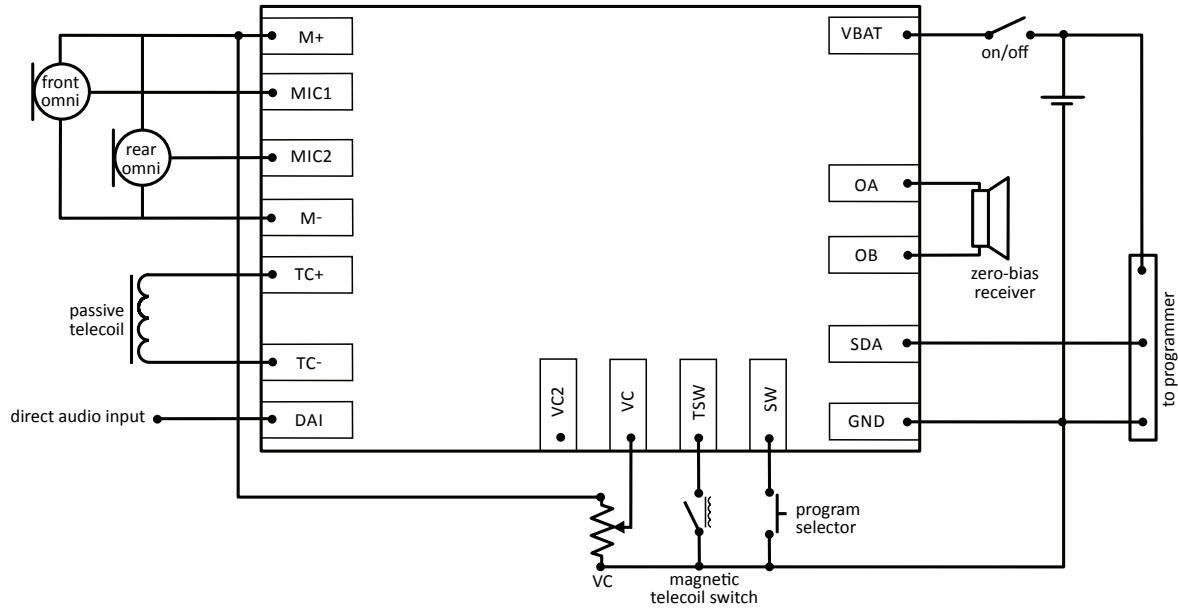

Wiring Schematic for Simple Programmable Application

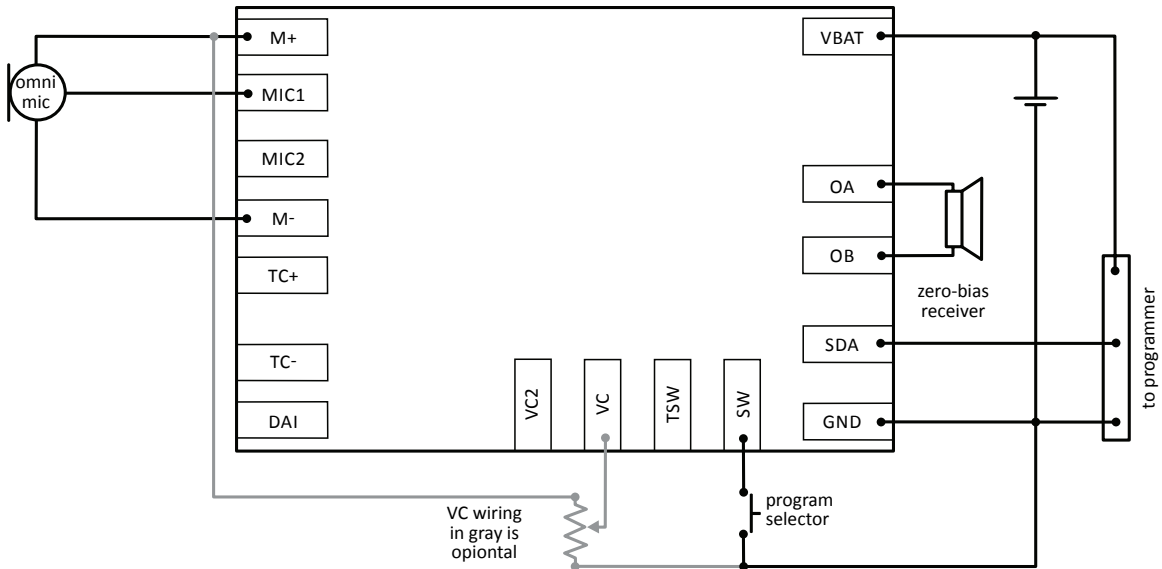

Wiring Schematic with Active Tcoil, VC, DAI, and MTO Switch

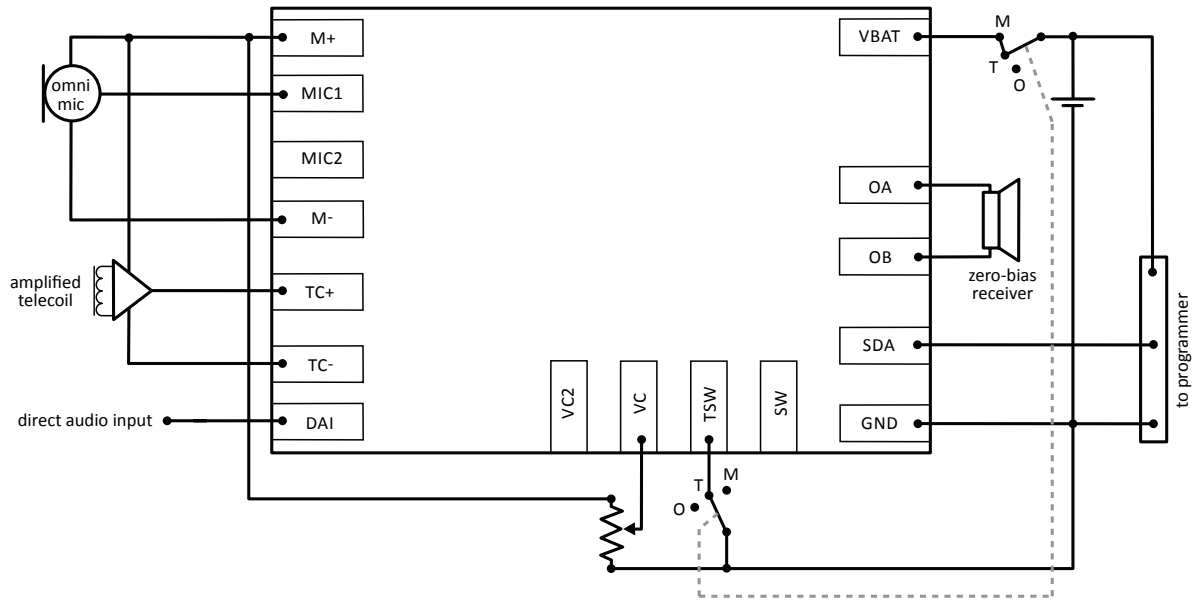

Wiring Schematic Showing VC with Program Switch

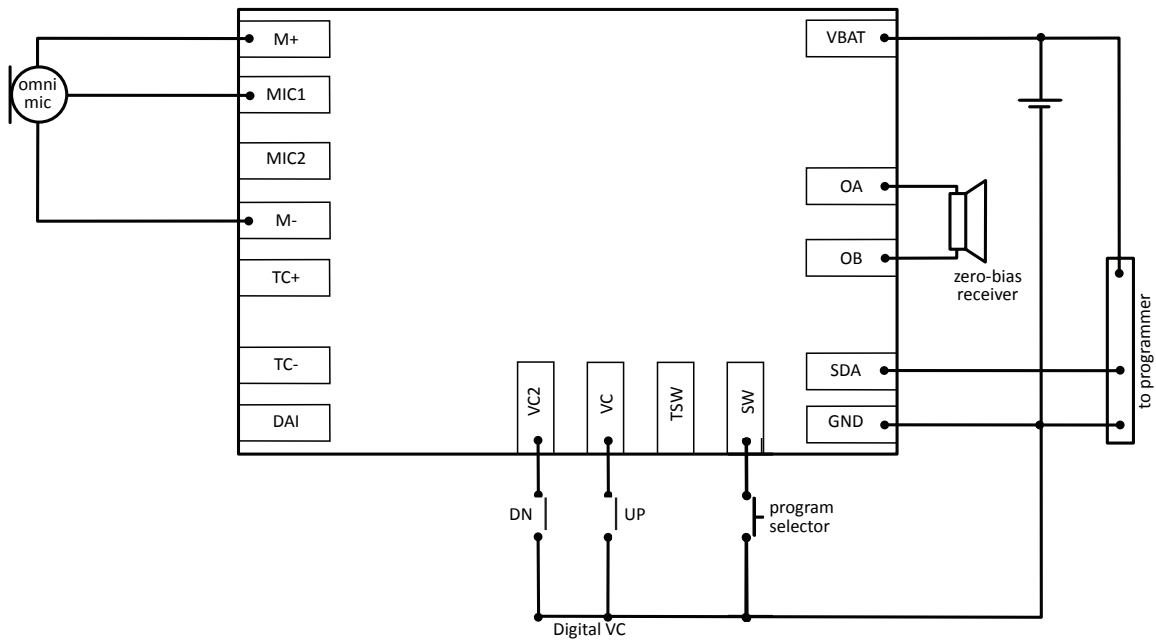

Programmer Wiring

Pin numbering of the DIN connector on the front of the HiPro, as seen facing the HiPro box

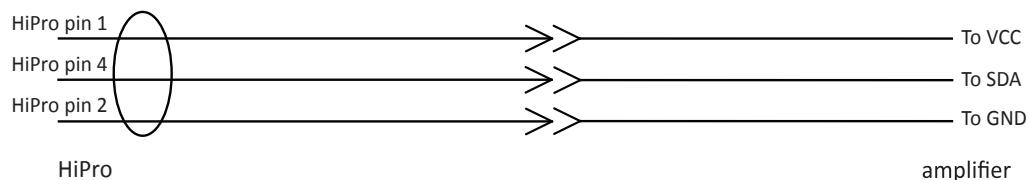
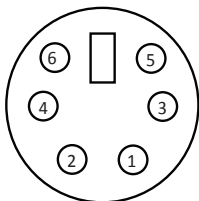

Technical Specifications

Parameter	Minimum	Typical	Maximum	Units	Condition
Minimum Operating Supply Voltage	1.0	1.25	2.0	V	
Supply Current	--	1.0	--	mA	AFC enabled at idle
Clock Frequency	--	3.84	--	MHz	
Sampling Frequency	--	16	--	kHz	
Bandwidth	--	8	--	kHz	
Input Noise	--	5.4	7.4	uVrms	bandwidth 200-8000 Hz
Dynamic Range	90	--	--	dB	max input signal with THD < 2%
Output Impedance, Standard Mode	--	5	--	ohms	
Output Impedance, High Power Mode	--	2.5	--	ohms	

SOLDERING INFORMATION

Customer Attach Process	Process Parameters	Max Hybrid Temp	Recommended materials to attach hybrid
Hand Solder Wire	Set iron tip temp to 650°–715° F. Max dwell time of 2 seconds. Allow 10 seconds between solder operations.	250° C	Use SAC 305 solder wire
Flip Clip	Reflow in convection oven—see profile below for recommended reflow temperature.	250° C	Print SAC 305 paste onto pads. Flip hybrid onto wet paste and reflow. Alternate method is to apply flux to the pads then flip hybrid onto fluxed pads and reflow. Recommended flux is indalloy tac flux 025 (this is a water soluble flux).

Solder Reflow Temperature Profile
(Lead-free SAC Alloy)

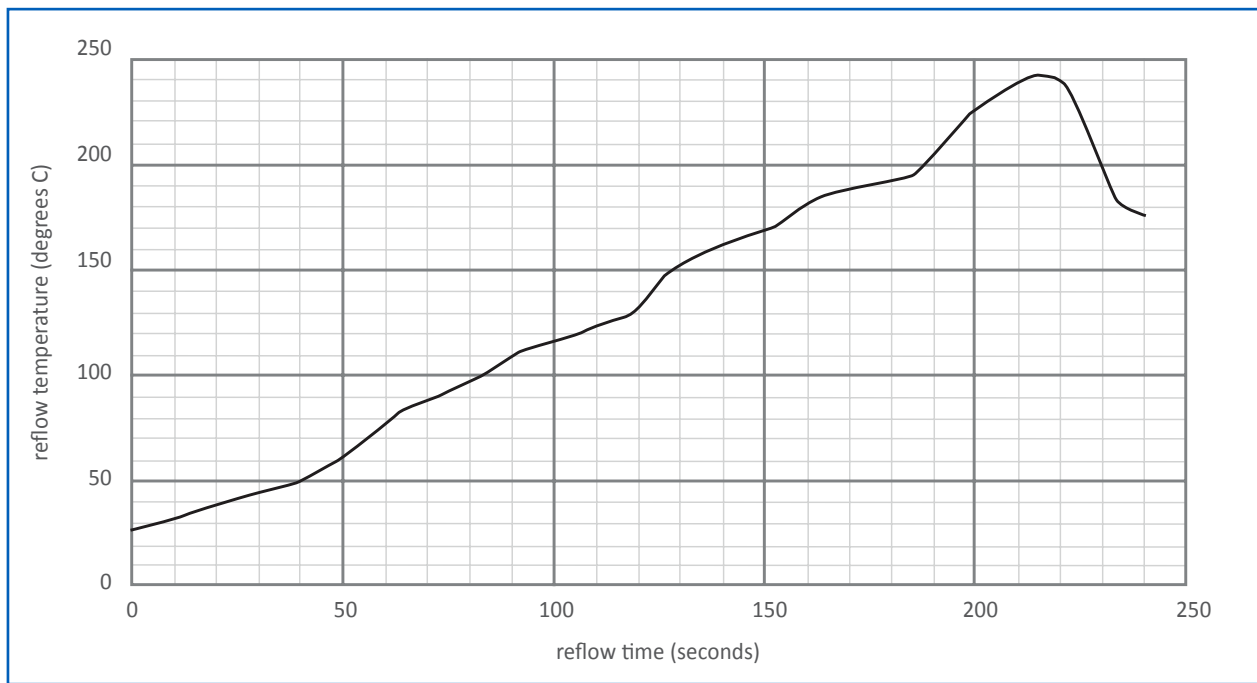

For more information on IntriCon products, visit www.intricon.com or email hearinghealthsales@intricon.com

Contact Information:

INTRICON CORPORATION

1260 Red Fox Road
 Saint Paul, MN 55112
 Tel: 651.636.9770
 Fax: 651.636.9503
 Website: www.intricon.com
 Email: hearinghealthsales@intricon.com

In Europe:

INTRICON GMBH
 Kesselschmiedstrasse 10
 D-85354 Freising, Germany
 Telefon: 049-8161-4804-0
 Telefax: 049-8161-4804-18
 Email: service@intricon.de

This product may be covered by one or more of the following patents, as well as patents pending: 8,355,517; 8,605,927; 8,767,987; D671,218; 9,571,939; 9,832,578; 6,678,386; D525,617; D527,377; D567,232; D588,110; 7,519,193; 8,358,797.

