

- R11, R12, R31, R32 define the GAIN and if MASTER o SLAVE mode
- With the value R11=100K and R12=20K the GAIN is 26dB and MASTER mode
- With the value R31=47K and R32=75K the GAIN is 26dB and SLAVE mode
- See Table 1 Gain and Master/Slace datasheet TPA3118D2 by Texas Instruments

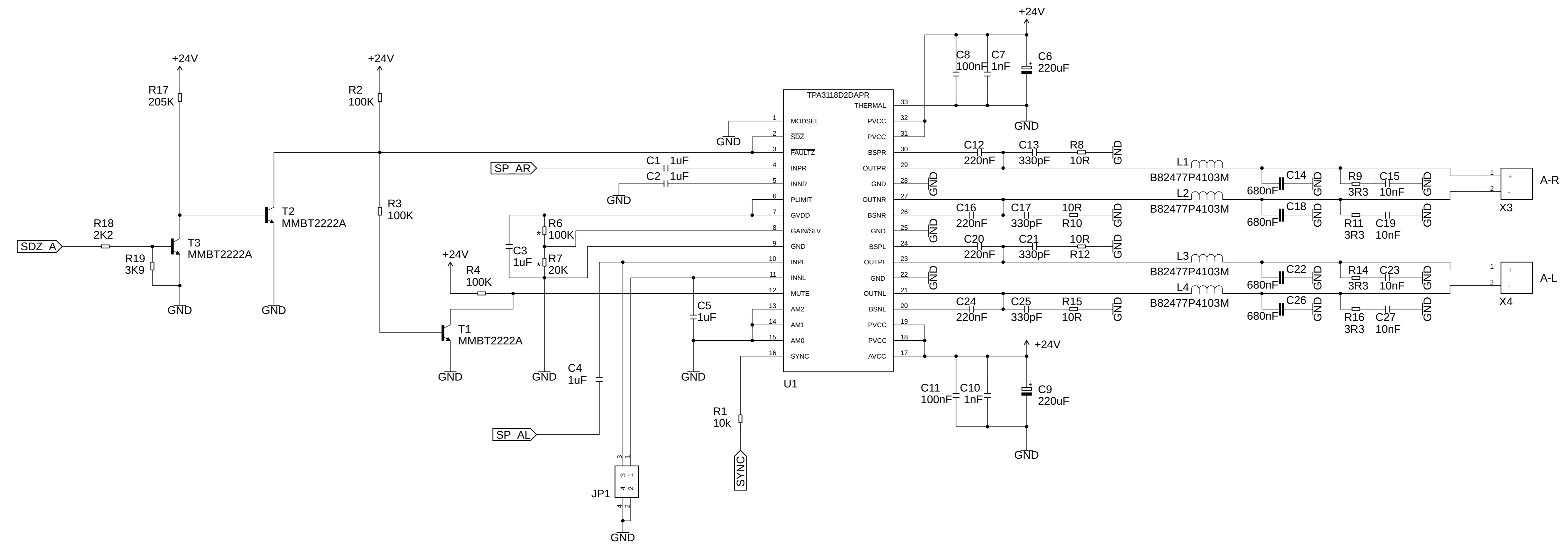

PBT mode with JP1 pin 1-2 and 3-4 closed

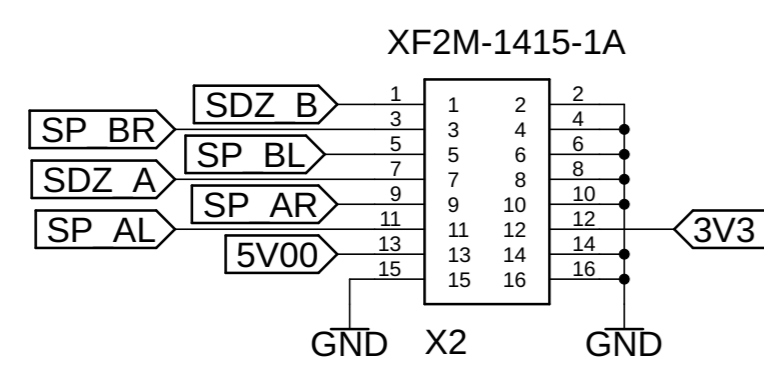
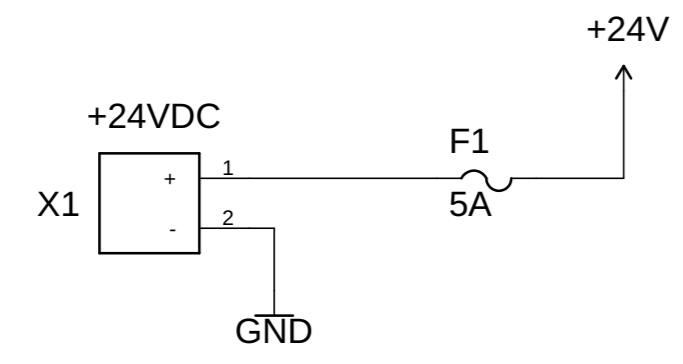
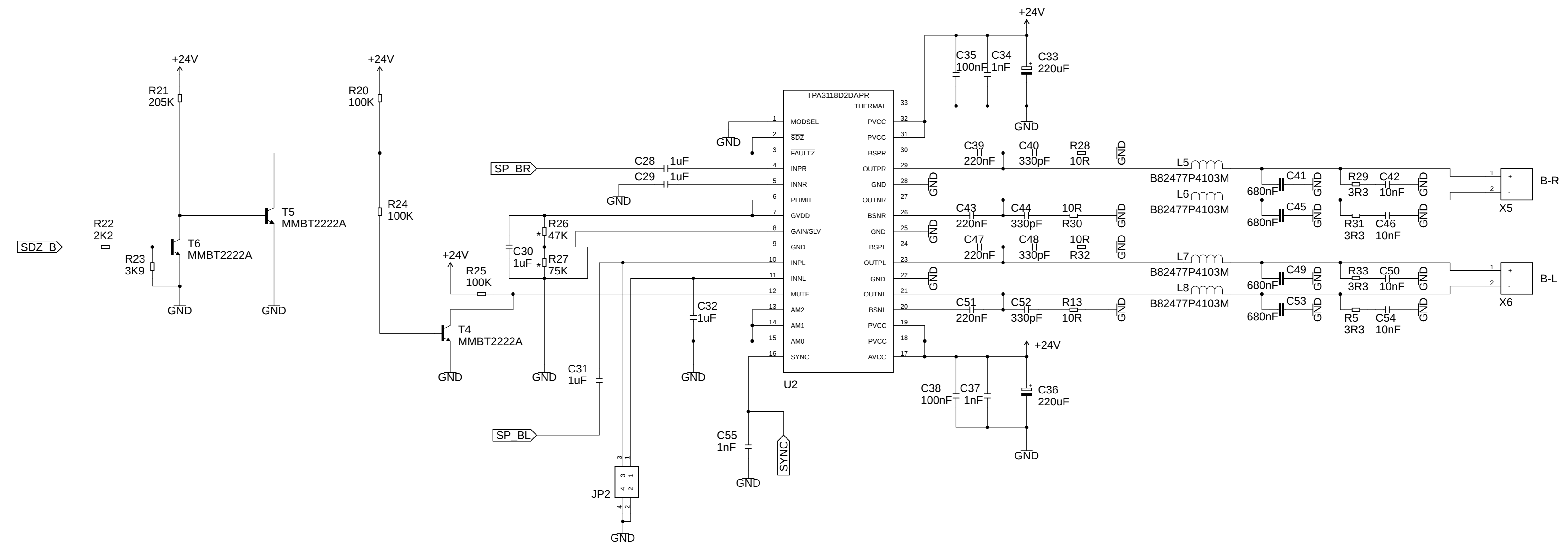

PBT mode with JP2 pin 1-2 and 3-4 closed

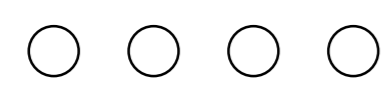

Title	K-AMPLI - AMPLIFIER		
Size	A2	Drawn	fmassaini
Rev.	1.0	Approved	fmassaini
Date	18/11/18	Page	1/1