

AMP PCB (AMP PART)

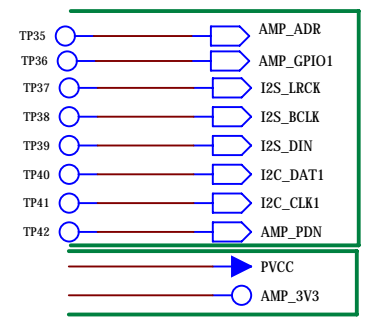
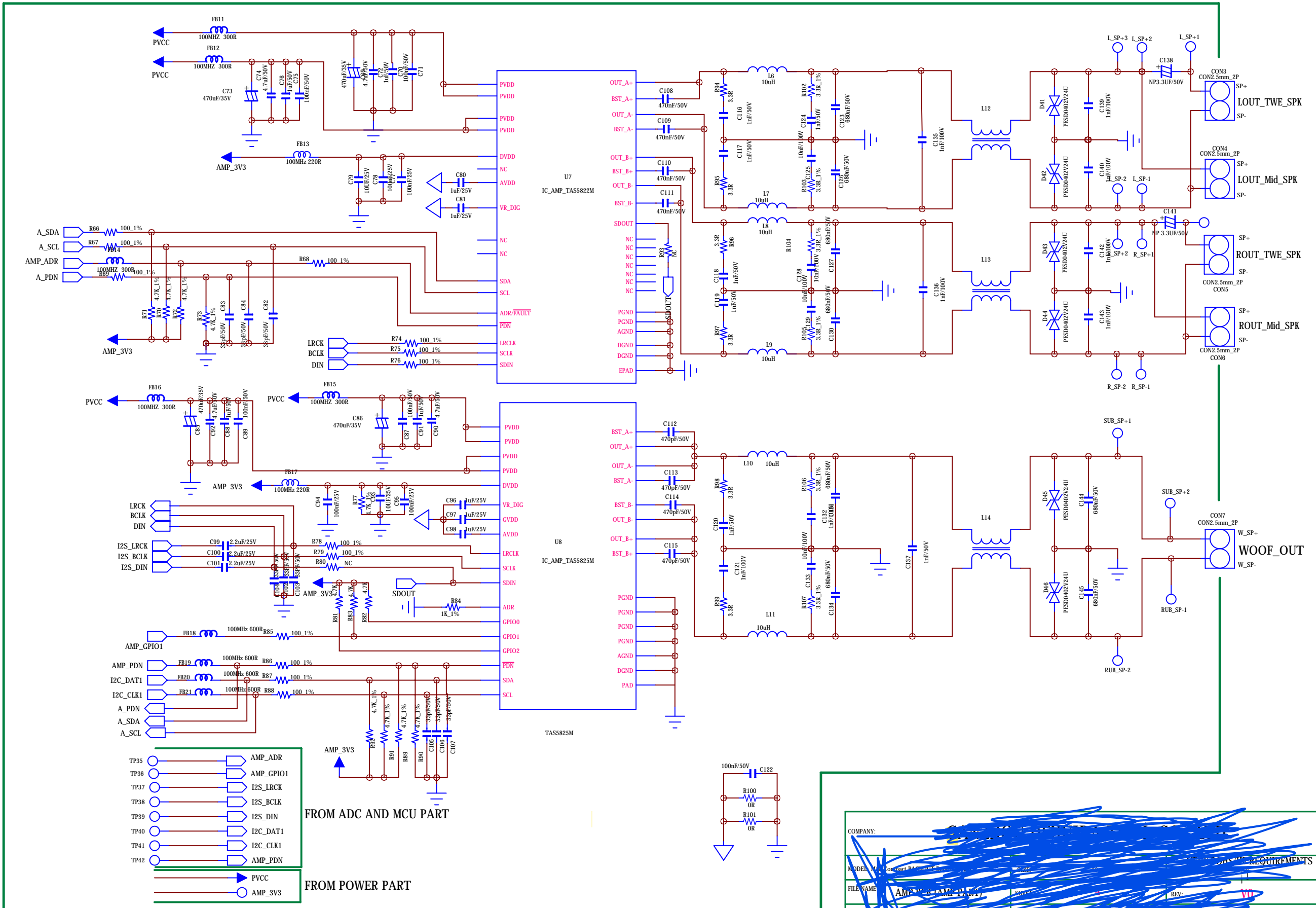

FROM ADC AND MCU PART

FROM POWER PART

COMPANY:			
MODEL:			
FILE NAME:	AMP PCB (AMP PART)	DESIGNER:	Y. Chen
DR / MR:	Y. Chen	DATE:	2024.04.30
DATED:	2024.04.30	DATE:	2024.

D

C

B

A

D

C

B

A