

REVISION RECORD			
LTR	ECO NO:	APPROVED:	DATE:

- 1.del R225
- 2.R71=10k
- 3.C227,C269 to 0603 decal
- 4.del R283,Q11
- 5.add Q8,Q10
- 6.del R295,Q12
- 7.NC R231,add R226=0R
- 8.del R227,add R230=0R
- 9.R284=4.7k
- 10.C199=47pF
- 11.del R240,add R246=0R
- 12.NC R250,add R233

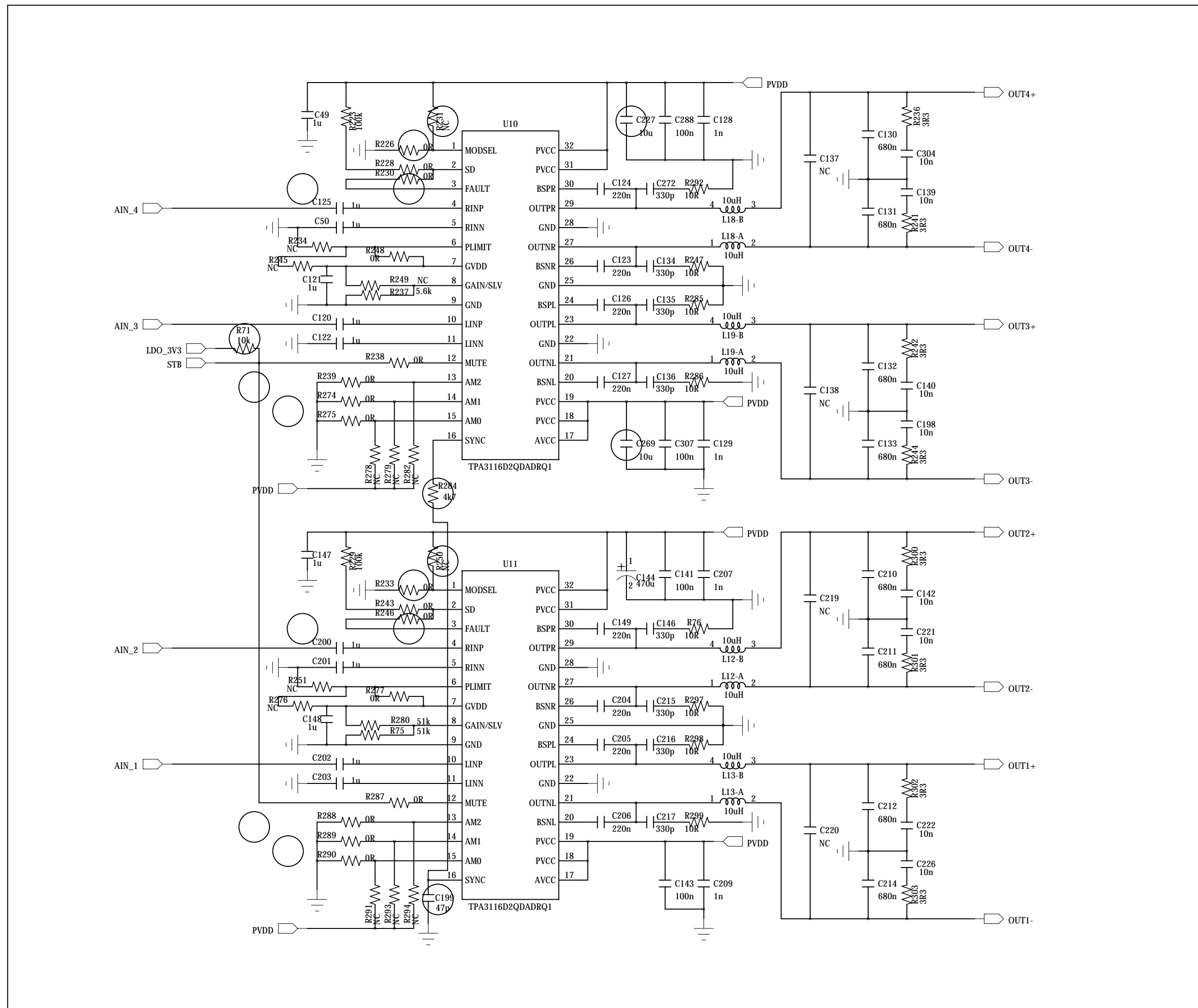

COMPANY: <Company Name>			
TITLE: <Title>			
DRAWN: TQ	DATED: 2022-3-16	CODE: -	SIZE: C
CHECKED: LC	DATED: 2022-3-16	DRAWING NO: 03	REV: 03
QUALITY CONTROL: <QC By>	DATED: 2022-3-16	SCALE: <Scale>	
RELEASED: TQ	DATED: 2022-3-16	SHEET: 4 of 5	