

Audio Power Amplifier

PN: 1410028594-01

13.3 Layout Example

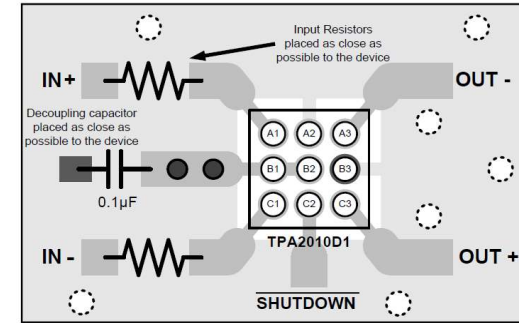

- Top Layer Ground Plane
- Top Layer Traces
- Pad to Top Layer Ground Plane
- Via to Power Supply
- Via to Bottom Layer Ground Plane

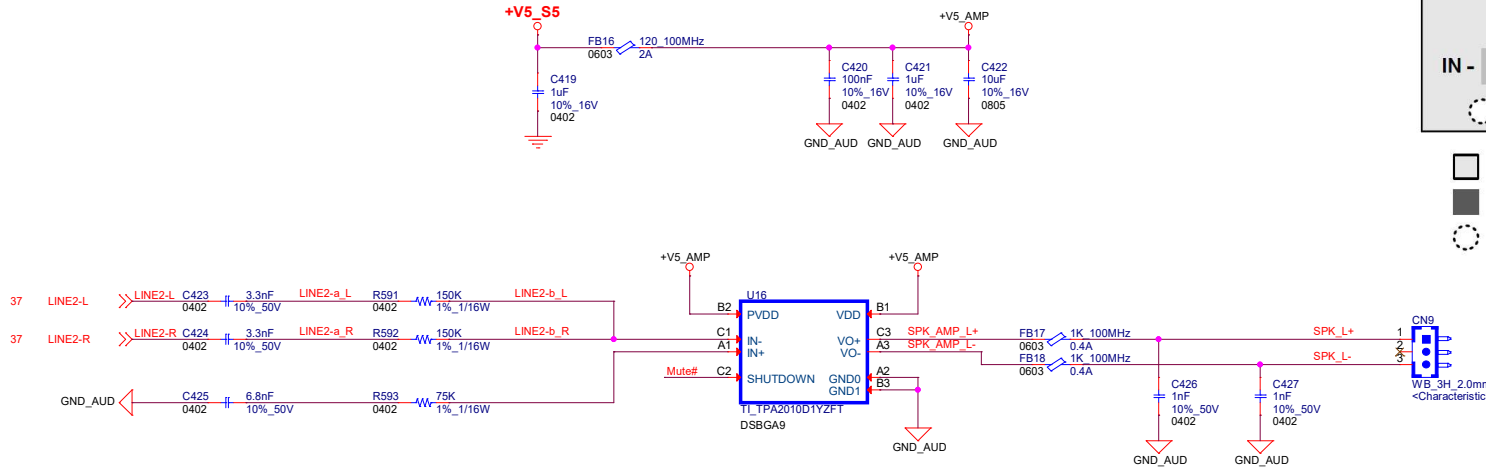

PART NUMBER	SPEAKER CHANNELS	SPEAKER AMP TYPE	OUTPUT POWER (W)	PSRR (dB)
TPA2010D1	Mono	Class D	2.5	75
TPA2005D1	Mono	Class D	1.4	75
TPA2011D1	Mono	Class D	3.2	86

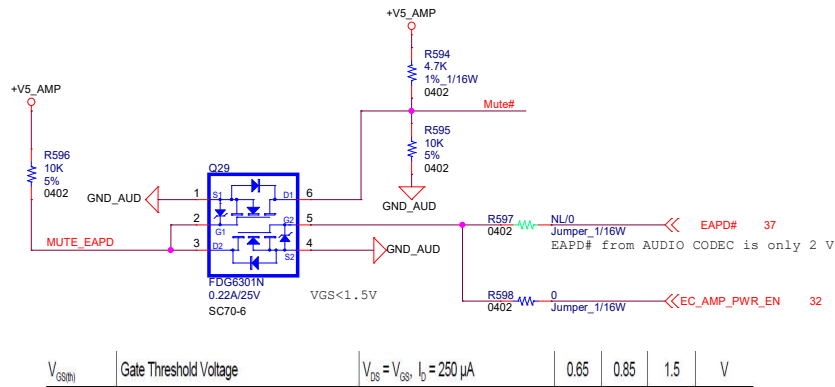

$V_{GS(th)}$	Gate Threshold Voltage	$V_{GS} = V_{DS}, I_D = 250 \mu A$	0.65	0.85	1.5	V
--------------	------------------------	------------------------------------	------	------	-----	---