

PurePath™ Console Motherboard

This manual describes the operation of the PurePath™ Console Motherboard (PPCMB), revisions D, E, and F. The PPCMB connects to device under test (DUT) boards. These can be evaluation modules (EVM) or reference boards (REF). The PurePath Console graphical user interface (PPC) is used to initialize and operate the PPCMB and the DUT. The main contents of this document are:

- Hardware implementation and descriptions
- Software implementation and descriptions
- System operations (hardware and software)
- Example with TAS5760xEVM (DUT)

Contents

1	Hardware Overview.....	3
	1.1 PurePath Console Motherboard Features.....	4
	1.2 PurePath Console Motherboard Functions.....	4
	1.3 PurePath Console Motherboard Detailed Operations.....	5
2	PurePath Console Motherboard Setup and Software Installation.....	6
	2.1 PurePath Console Motherboard Setup	6
	2.2 Software Installation	7
3	Using the PurePath Console Software with the PurePath Console Motherboard.....	9
	3.1 Device Main Tab	9
	3.2 Device Block Diagram Tab	9
	3.3 Pop-up Windows	10
	3.4 Direct I ² C Access Tab	11
	3.5 Device Registers Tab.....	11
4	Board Layouts, Bill of Materials, and Schematic	12
	4.1 PurePath Console Motherboard Layouts, Revisions D and E.....	12
	4.2 PurePath Console Motherboard Layouts, Revision F	14
	4.3 Bill of Materials	16
	4.4 PurePath Console, Revision D and E, Schematic	28
	4.5 PurePath Console, Revision F, Schematic	38

List of Figures

1	PurePath Console Motherboard Revision D	3
2	PurePath Console Motherboard Signal Flow (Revisions D and E)	4
3	Device Manager.....	5
4	PurePath Console Motherboard Connection.....	6
5	Target Selection List.....	7
6	Add Target List.....	8
7	PurePath Console Motherboard and TAS5760xEVM.....	8
8	DUT Block Diagram (TAS5760)	9
9	Digital Gain Pop-Up.....	10
10	Analog Gain Pop-Up	10
11	Direct I ² C Access	11

PurePath, MPS430 are trademarks of Texas Instruments.
Windows is a registered trademark of Microsoft Corporation.
All other trademarks are the property of their respective owners.

12	Device Registers Tab	11
13	PurePath Console Motherboard, Revision D and E, Top Composite Assembly	12
14	PurePath Console Motherboard, Revision D and E, Copper Layer 2	12
15	PurePath Console Motherboard, Revision D and E, Copper Layer 3	13
16	PurePath Console Motherboard, Revision D and E, Bottom Composite Assembly	13
17	PurePath Console Motherboard, Revision F, Top Composite Assembly	14
18	PurePath Console Motherboard, Revision F, Copper Layer 2	14
19	PurePath Console Motherboard, Revision F, Copper Layer 3	15
20	PurePath Console Motherboard, Revision F, Bottom Composite Assembly	15
21	PurePath Console Revisions D and E (1 of 10).....	28
22	PurePath Console Revisions D and E (2 of 10).....	29
23	PurePath Console Revisions D and E (3 of 10).....	30
24	PurePath Console Revisions D and E (4 of 10).....	31
25	PurePath Console Revisions D and E (5 of 10).....	32
26	PurePath Console Revisions D and E (6 of 10).....	33
27	PurePath Console Revisions D and E (7 of 10).....	34
28	PurePath Console Revisions D and E (8 of 10).....	35
29	PurePath Console Revisions D and E (9 of 10).....	36
30	PurePath Console Revisions D and E (10 of 10)	37
31	PurePath Console Revision F (1 of 12)	38
32	PurePath Console Revision F (2 of 12)	39
33	PurePath Console Revision F (3 of 12)	40
34	PurePath Console Revision F (4 of 12)	41
35	PurePath Console Revision F (5 of 12)	42
36	PurePath Console Revision F (6 of 12)	43
37	PurePath Console Revision F (7 of 12)	44
38	PurePath Console Revision F (8 of 12)	45
39	PurePath Console Revision F (9 of 12)	46
40	PurePath Console Revision F (10 of 12).....	47
41	PurePath Console Revision F (11 of 12).....	48
42	PurePath Console Revision F (12 of 12).....	49
43	PurePath Console Revisions D, E, and F.....	50

List of Tables

1	Bill of Materials, Revision D.....	16
2	Bill of Materials, Revision E	19
3	Bill of Materials, Revisions F.....	23

1 Hardware Overview

The PPCMB provides control signals and audio signals to the DUT. The PPC sends the control signals to the TAS1020B device through the USB human-interface device (HID) protocol. The TAS1020B device converts to I²C and sends to the appropriate I²C address. The audio signals are provided through USB audio, SPDIF, or analog signals. The aforementioned signals are converted to I²S – see [Figure 2](#).

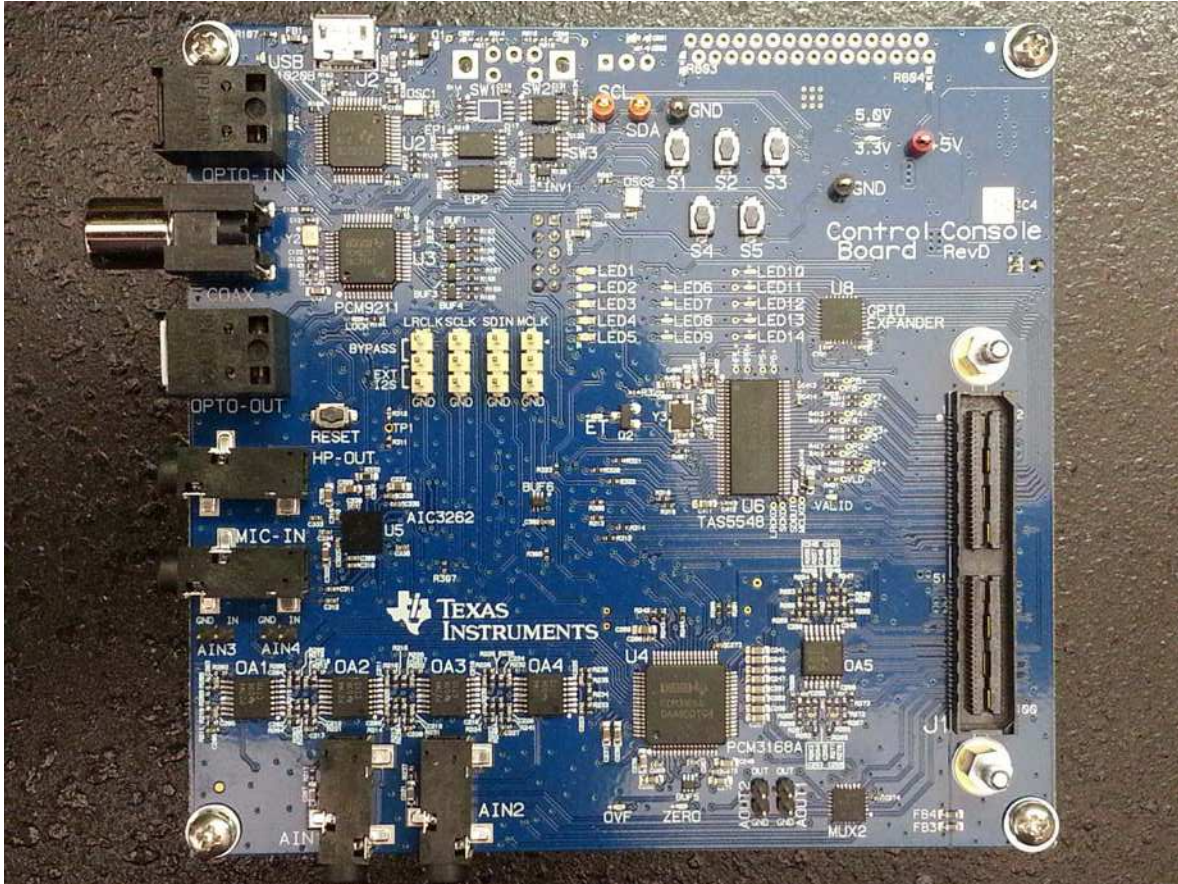

Figure 1. PurePath Console Motherboard Revision D

Figure 2 shows the PPCMB Revisions D and E signal flow. For Revision F, refer to the block diagram in Section 4.5.

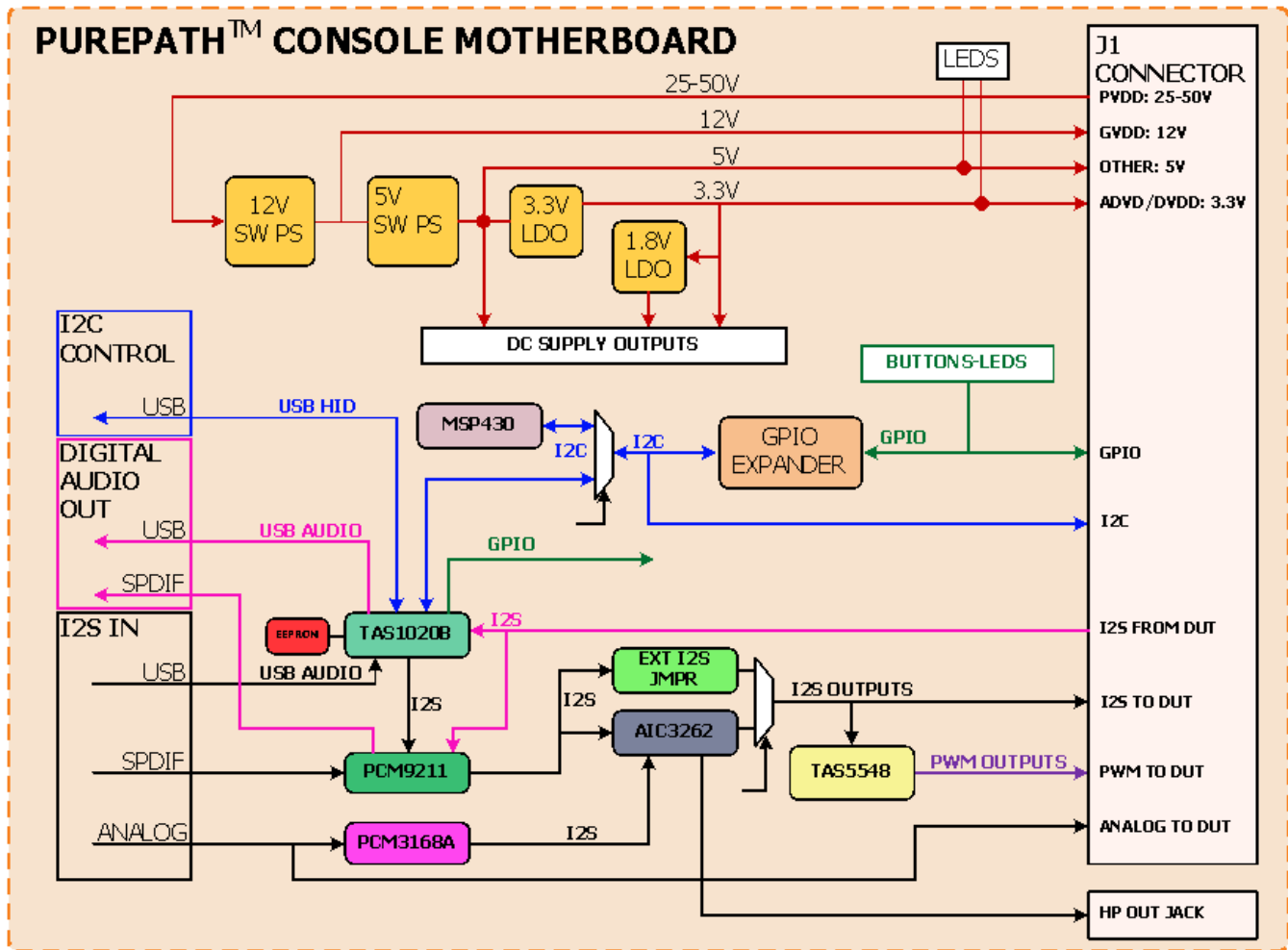

Figure 2. PurePath Console Motherboard Signal Flow (Revisions D and E)

1.1 PurePath Console Motherboard Features

- The PPC sends I²C control signals through the USB link: the initialization sequence is sent utilizing auto DUT detection reducing hardware setup time
- Three I²S audio sources: USB audio, SPDIF, and ADC
- Audio processing: TLV320AIC3262 (mini-DSP)
- Dual asynchronous sample-rate converters (ASRC) PWM modulator: TAS5548
- Interface with PurePath Smart Amp and audio devices designed for use in TV, mini-component, AVR application

1.2 PurePath Console Motherboard Functions

The PPCMB is organized into two sections: control data and audio data. Control data is routed through the I²C bus and audio data is routed through the I²S bus. An analog signal can also be routed directly to and from the DUT.

The control data is sent from the PPC through the TAS1020B USB to I²C commands. The MSP430™ microcontroller can also be used independent of the PC host. The MSP430 device is used for stand-alone demonstrations; therefore, it is configured for each application.

The digital audio data input is selectable from USB audio, optical SPDIF, coaxial SPDIF, and analog ADC. When a digital audio data input is selected, the PPC will automatically send appropriate scripts to the device in-use.

When direct audio analog input is required, the PPCMB will provide this signal through a line-in connector.

- TLV320AIC3262 (mini-DSP) provides programmable algorithms and audio post-processing for many applications
- PWM modulator with dual ASRC and post-processing capability can be used in mini-component or AVR systems. The PWM output is connected directly to TI's high-power (300 W) amplifier TAS5624A EVM.
- I²S audio from the DUT can be captured through the USB link or optical SPDIF for signal analysis

1.3 PurePath Console Motherboard Detailed Operations

The following information can be used as a debugging guide.

Upon power-on, the PPCMB uses optical SPDIF input (default). The I²S signals can be seen with an oscilloscope probe at the pin headers LRCLK, SCLK, SDIN, and MCLK.

EEPROM 1 (EP1) is flashed with firmware that runs the TAS1020B for the USB audio (USB-miniEVM), HID, and the USB composite device. [Figure 3](#) shows the Device Manager.

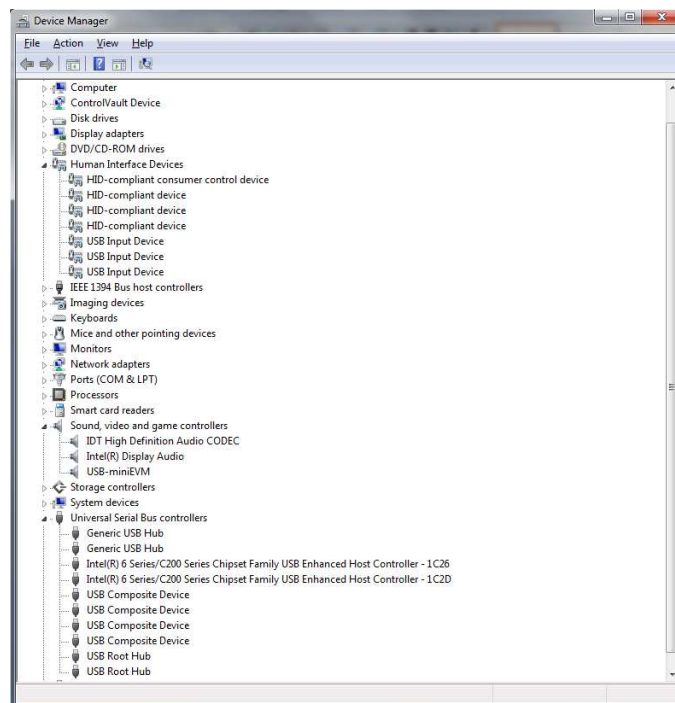

Figure 3. Device Manager

When the PPCMB is plugged in to a PC, the Device Manager should show all of the USB devices shown in [Figure 3](#). If one of the devices does not show up, the PPCMB will not work correctly.

When the PPC is executed, the PPC uses the USB audio as the default I²S input. The PCM9211 acts as the multiplexor that selects among the following I²S signal sources: optical SPDIF, coaxial SPDIF, and USB audio. The output of the PCM9211 device is routed to the TLV320AIC3262 device. The signal from the TLV320AIC3262 is then routed to the TAS5548 device and the output connector (J1). The TLV320AIC3262 can be bypassed by switching the MUX3 select control signal to high and the MUX4, MUX5, and MUX6 select control signals to low by using the PPC; and adding jumpers between pins 1 and 2 of the header LRCLK, SCLK, SDIN, and MCLK pins.

The I²S header pins are used for three purposes: probing I²S signals coming out of PCM9211, bypassing I²S signals from TLV320AIC3262 and using the PCM9211 I²S signals, and bypassing I²S signals from the TLV320AIC3262 and using an external I²S source.

The TAS5548 device is used for PWM input devices such as the TAS5624. The TAS5548 is TI's latest 8-channel PWM modulator and has dual ASRC with audio post processing. For more information go to www.ti.com/product/TAS5548.

The PCM3168A takes analog inputs (AIN1 and AIN2) and routes them to the TLV320AIC3262. AIN1 is converted to I²S and routed to TAS5548 and J1. The analog switch, MUX2, routes analog input directly to DUT through J1.

The GPIO extender (TCA6424A – U8) is used for initialization of the multiplexors and discrete signals. It is controlled from the PPC through the I²C.

The MSP430 is populated but is not programmed. It is used in place of a PC for specifically-designed demonstrations using a combination of TI devices on the PPCMB and a DUT evaluation board or reference boards.

2 PurePath Console Motherboard Setup and Software Installation

This section describes the PPCMB setup and software installation. Since the PPCMB connects to one of the DUT EVMs, it is necessary to show the connection in this section. The TAS5760xEVM is used for this purpose.

2.1 PurePath Console Motherboard Setup

Figure 4 shows the PPCMB connection.

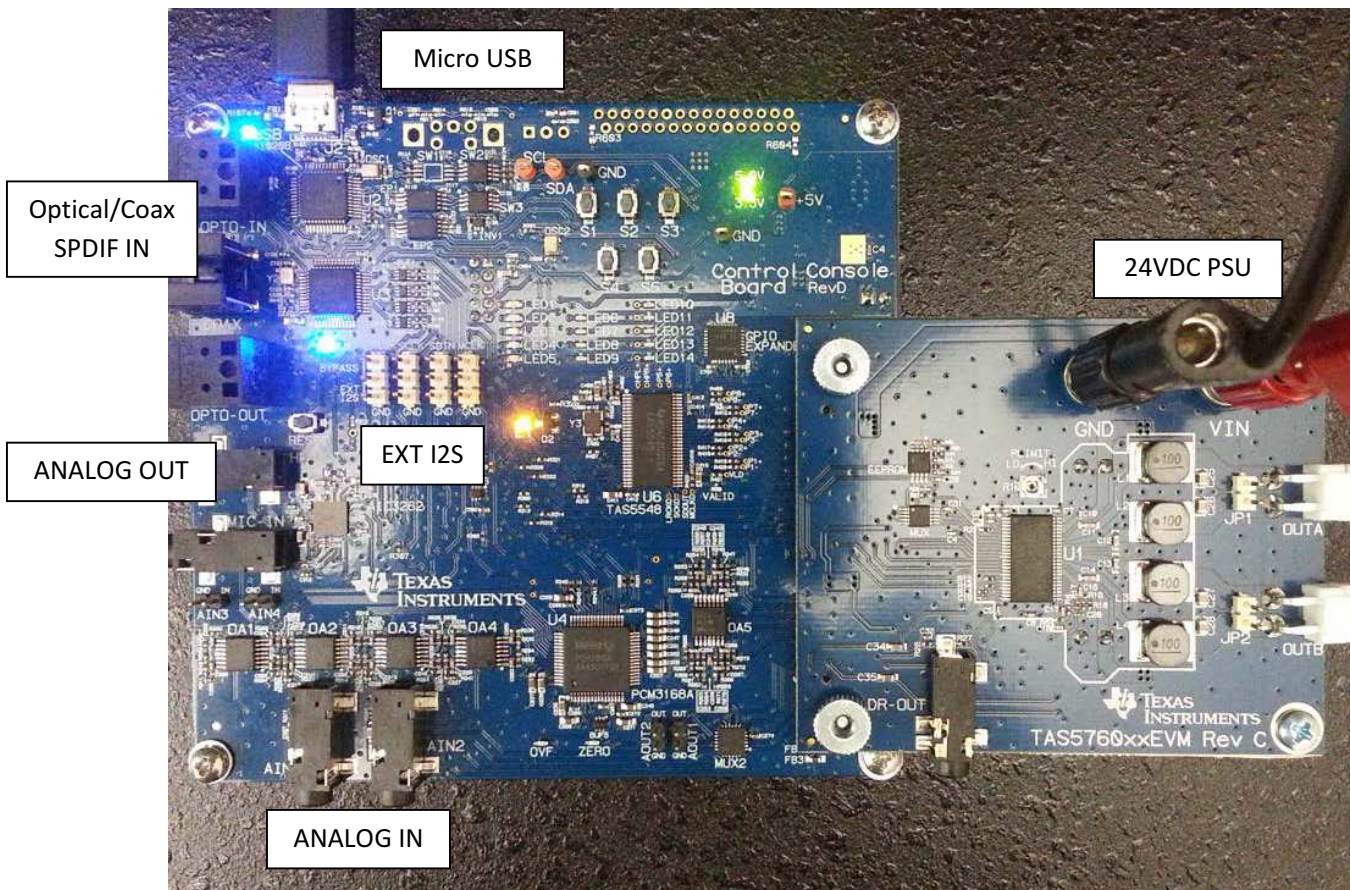

Figure 4. PurePath Console Motherboard Connection

The hardware requirements are listed as:

- Desktop or laptop PC running either Windows® XP or Windows 7
- DUT EVM such as TAS5760xEVM; It is used here as an example
- Power supply 24 VDC
- Speakers and cables
- A USB micro type B cable
- Audio source: this can be a DVD player with appropriate SPDIF cable or Windows Media Player from Windows XP or Windows 7

For hardware setup, follow these steps:

- Step 1. Plug in the USB cable from the PC to the PPCMB; the USB Lock LED (blue) is illuminated
- Step 2. Connect the PPCMB to the DUT EVM, in this case the TAS5760xEVM
- Step 3. Connect the PSU to DUT EVM and turn on the power. 5-V and 3.3-V LEDs are illuminated
- Step 4. If an optical SPDIF source is used, the blue SPDIF clock-locked LED is illuminated
- Step 5. Disregard the orange LED indicating the energy threshold (ET) level is exceeded. The ET value must be cleared for the orange LED to be extinguished.

2.2 Software Installation

Download the PPC from the TI Web site (www.ti.com/tool/purepathconsole). The TI Web site has the latest release of the GUI.

Execute the GUI installation program, *Setup_PurePathConsole_Main_vxx_revxx.exe*. When the program is installed, the program group and shortcut icon is created in Start → Program → Texas Instruments Inc → PurePath Console → Choose Target. The Target Selection window is displayed; select TAS5760 as shown in [Figure 5](#).

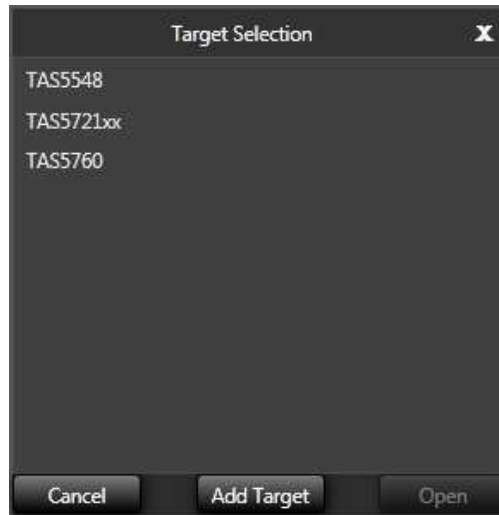

Figure 5. Target Selection List

If the device is not listed in the Target Selection list, click the **Add Target** button. Windows explorer displays. Navigate to the folder that contains the target zip files (plugins) and choose the DUT.

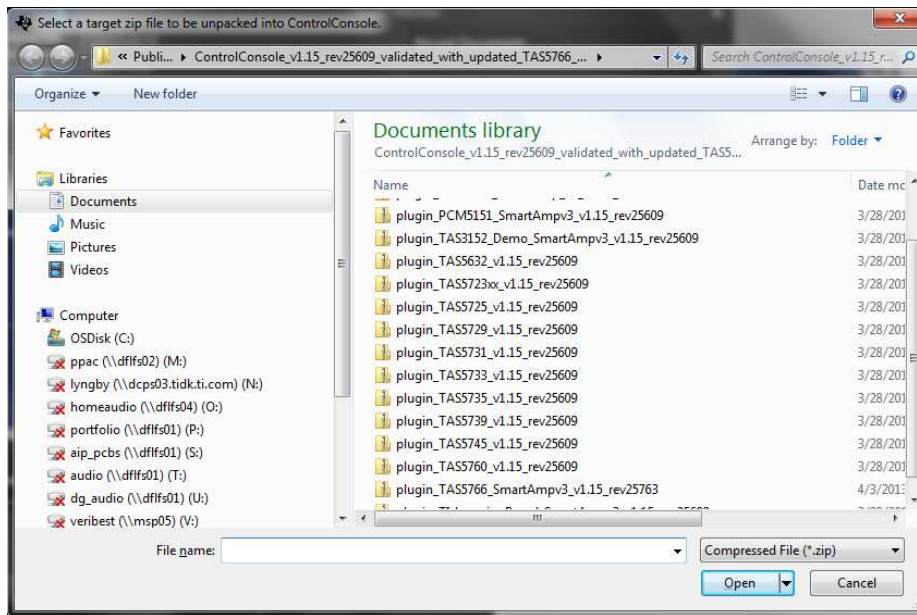

Figure 6. Add Target List

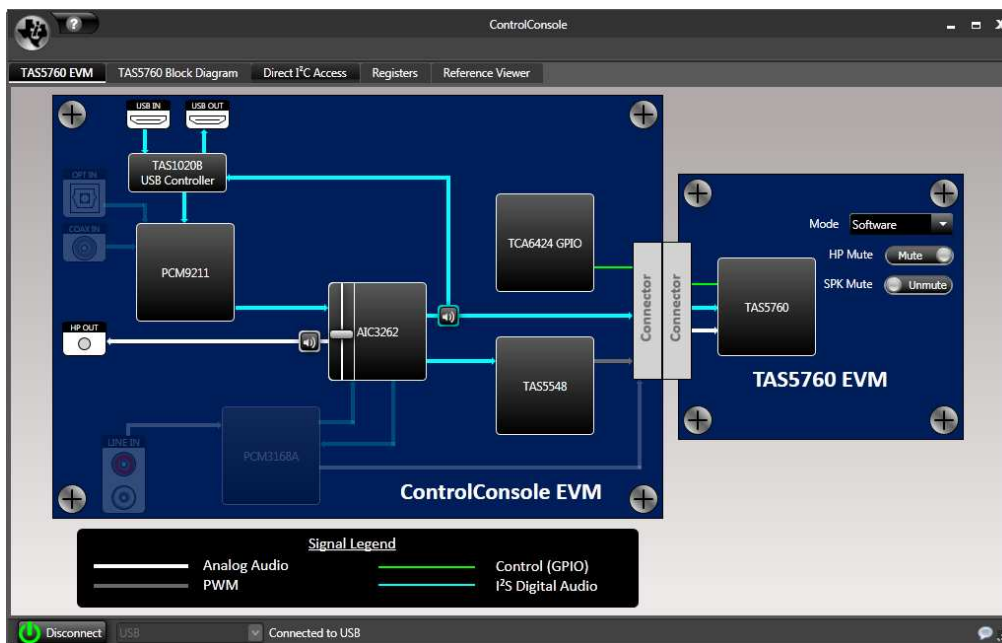

Figure 7. PurePath Console Motherboard and TAS5760x EVM

Click on the **Connect** button. The green LED on the bottom left corner of the PurePath Console window indicates the initialization of TAS5760 is valid.

The PPCMB is initialized with the selected USB audio (USB-miniEVM). Streaming audio from the USB host is routed to the DUT (TAS5760).

If optical SPDIF is used, simply click on the SPDIF/OPT symbol on the PPC, the I²S is routed with the optical SPDIF signal. Likewise, if analog input signal (line-in) is selected, the ADC (PCM3168A) is the source of I²S data.

3 Using the PurePath Console Software with the PurePath Console Motherboard

The TAS5760xEVM is initialized upon PPC startup. Audio is streaming to the speakers if the Windows Media Player (or similar program) is playing and mini-USB EVM is selected in the sound playback properties. The following indicators show both the PPC and TAS5760xEVM are operating correctly:

- On the PPCMB, the USB blue LED is on, the green LEDs for 3.3 V and 5 V are on
- On the PPC, the green LED on the bottom left corner is on

NOTE: For PPCMB, yellow LED indicator on for ET is normal. This indicates the energy threshold is above the default limit in the TAS5548. The VALID blue LED is on if the TAS5548 is correctly initialized.

3.1 Device Main Tab

The DUT tab is displayed when the PPC starts up. Click on the TAS5760 icon to be directed back to the device block diagram, as shown in [Figure 8](#).

3.2 Device Block Diagram Tab

This tab shows the device major blocks. The boxes with black background are selectable. When one is selected, it shows pop-up settings for the particular setting.

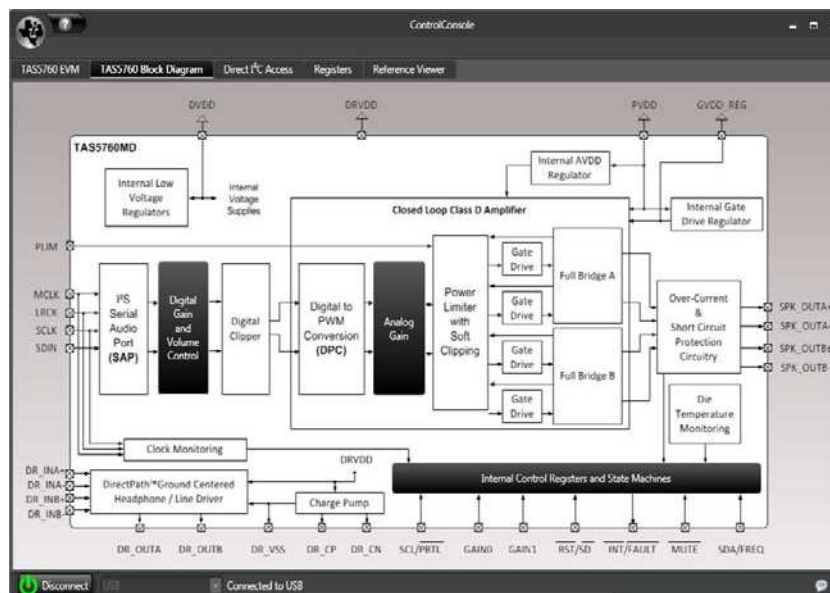

Figure 8. DUT Block Diagram (TAS5760)

3.3 Pop-up Windows

For the TAS5760, several settings are set through the I²C and the GUI facilitates these settings seamlessly using the pop-up windows shown in [Figure 9](#) and [Figure 10](#).

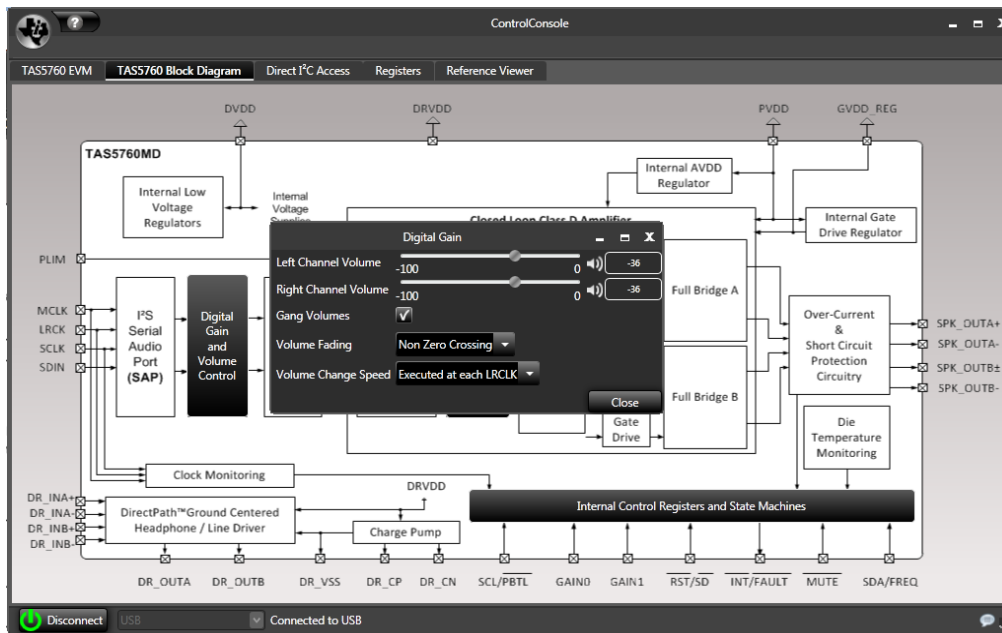

Figure 9. Digital Gain Pop-Up

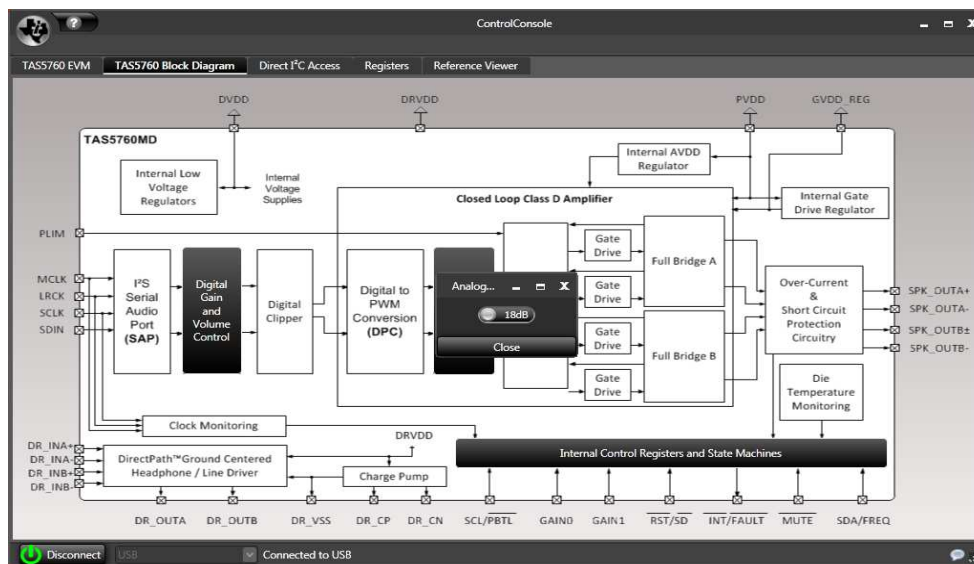

Figure 10. Analog Gain Pop-Up

3.4 Direct I²C Access Tab

I²C registers read and write can be performed on this tab (see Figure 11). Type in the device I²C address and click the **Set** button. On the Direct I²C Read/Write box, type in a valid I²C register for read and type in both valid register and data for write.

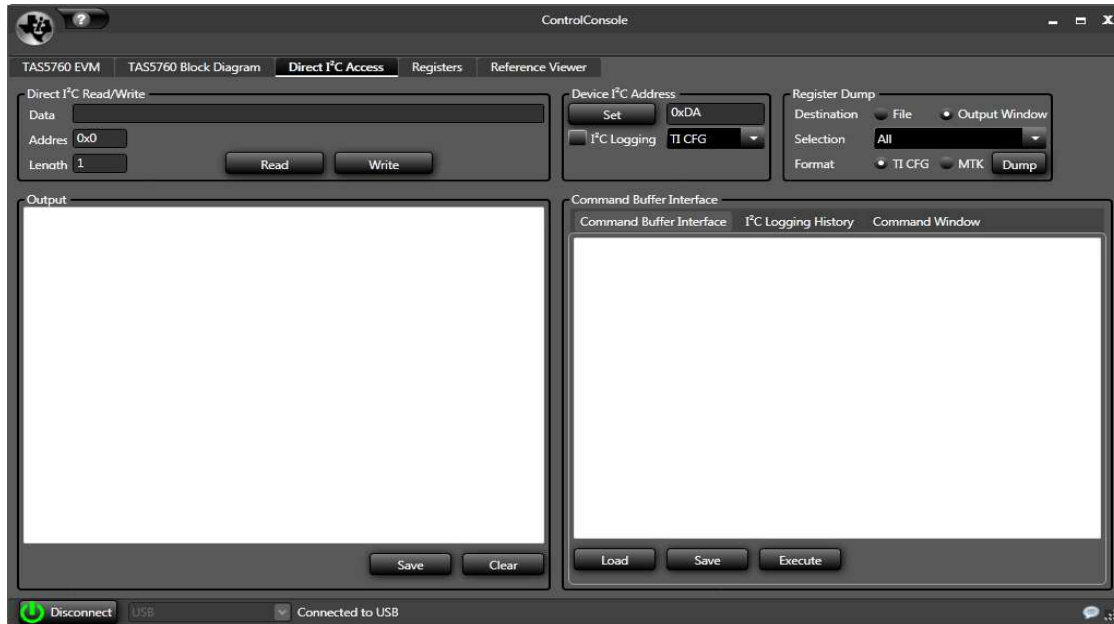

Figure 11. Direct I²C Access

3.5 Device Registers Tab

The device registers tab (Figure 12) shows the current I²C registers values (hexadecimal and decimal) in the TAS5760.

Sub Address	Register Name	Dec Value	Hex Value	Bit7	Bit6	Bit5	Bit4	Bit3	Bit2	Bit1	Bit0
0x00	Device Identification	0	0x00	0	0	0	0	0	0	0	0
0x01	Power Control	253	0xFD	1	1	1	1	1	1	0	1
0x02	Audio Path Configuration	20	0x14	0	0	0	1	0	1	0	0
0x03	Volume Control Configuration	128	0x80	1	0	0	0	0	0	0	0
0x04	Left Channel Volume Control	183	0xB7	1	0	1	1	0	1	1	1
0x05	Right Channel Volume	183	0xB7	1	0	1	1	0	1	1	1
0x06	Amplifier Control	81	0x51	0	1	0	1	0	0	0	1
0x07	Reserved	0	0x00	0	0	0	0	0	0	0	0
0x08	Error Status Register	0	0x00	0	0	0	0	0	0	0	0
0x09	Reserved	0	0x00	0	0	0	0	0	0	0	0
0x0A	Reserved	0	0x00	0	0	0	0	0	0	0	0
0x0B	Reserved	0	0x00	0	0	0	0	0	0	0	0
0x0C	Reserved	0	0x00	0	0	0	0	0	0	0	0
0x0D	Reserved	0	0x00	0	0	0	0	0	0	0	0
0x0E	Reserved	0	0x00	0	0	0	0	0	0	0	0
0x0F	Reserved	0	0x00	0	0	0	0	0	0	0	0

Figure 12. Device Registers Tab

4 Board Layouts, Bill of Materials, and Schematic

4.1 PurePath Console Motherboard Layouts, Revisions D and E

Figure 13 through Figure 16 show the board layouts for the PurePath Console Motherboard.

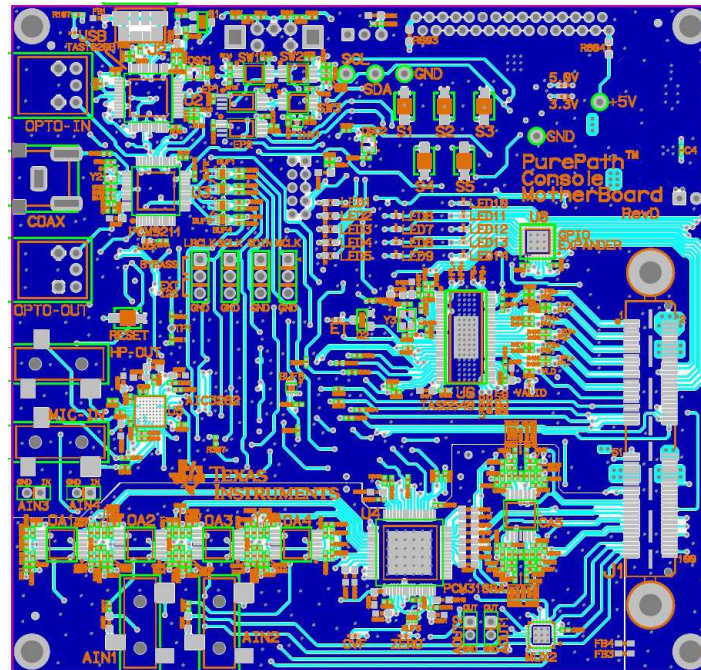

Figure 13. PurePath Console Motherboard, Revision D and E, Top Composite Assembly

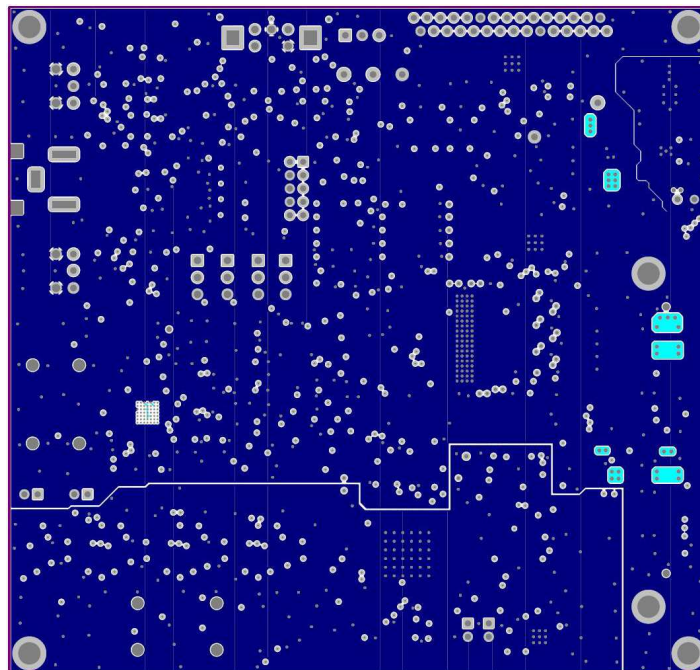

Figure 14. PurePath Console Motherboard, Revision D and E, Copper Layer 2

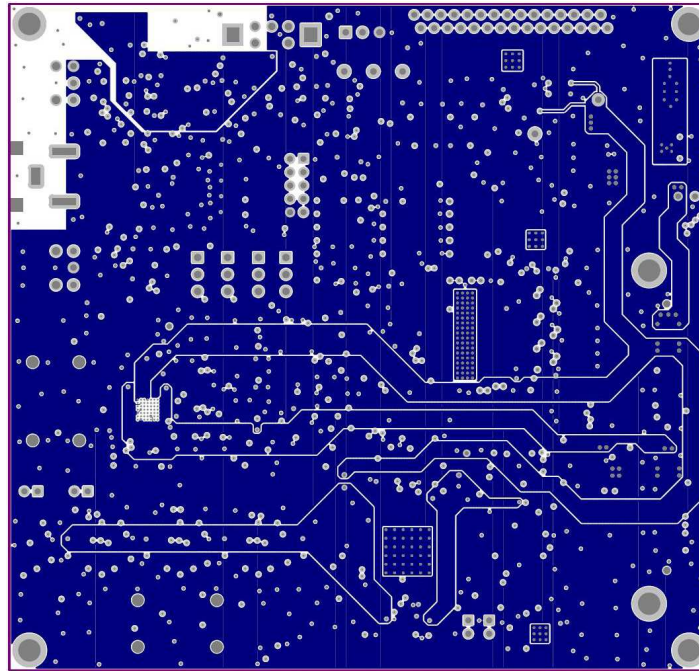

Figure 15. PurePath Console Motherboard, Revision D and E, Copper Layer 3

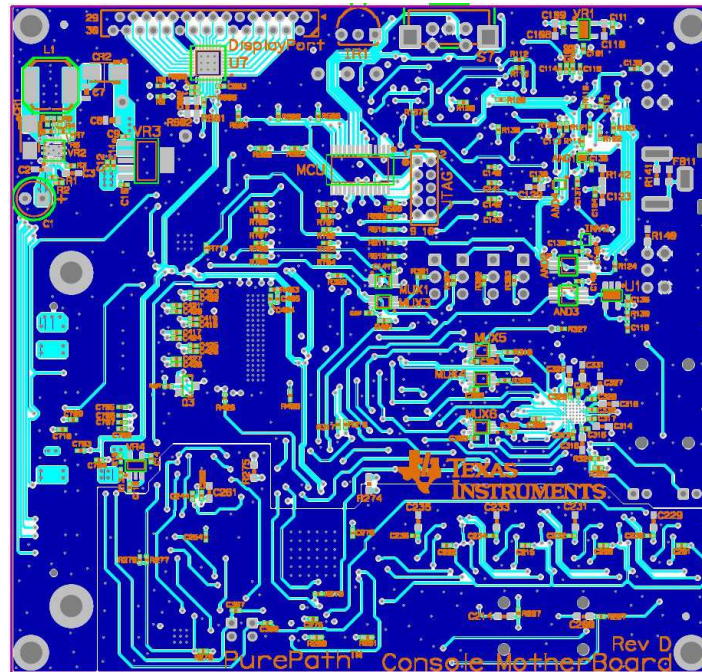

Figure 16. PurePath Console Motherboard, Revision D and E, Bottom Composite Assembly

4.2 PurePath Console Motherboard Layouts, Revision F

Figure 17 through Figure 20 show the board layouts for the PurePath Console Motherboard.

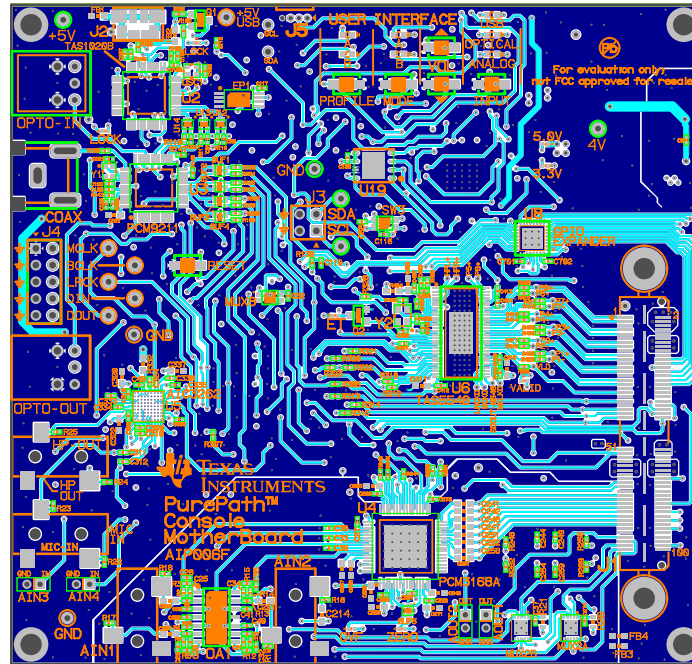

Figure 17. PurePath Console Motherboard, Revision F, Top Composite Assembly

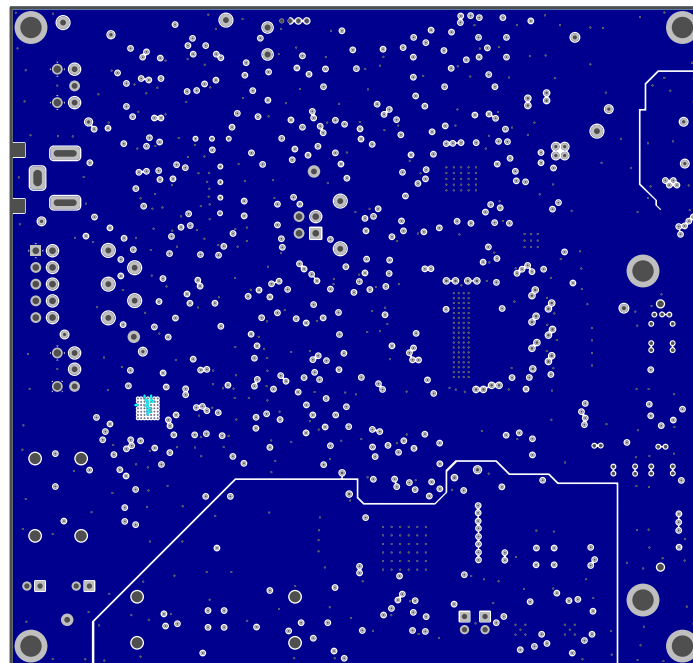

Figure 18. PurePath Console Motherboard, Revision F, Copper Layer 2

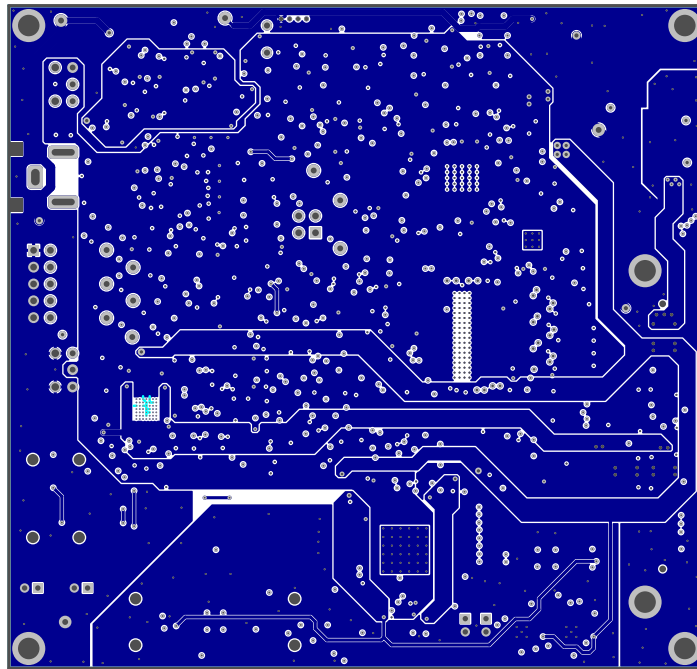

Figure 19. PurePath Console Motherboard, Revision F, Copper Layer 3

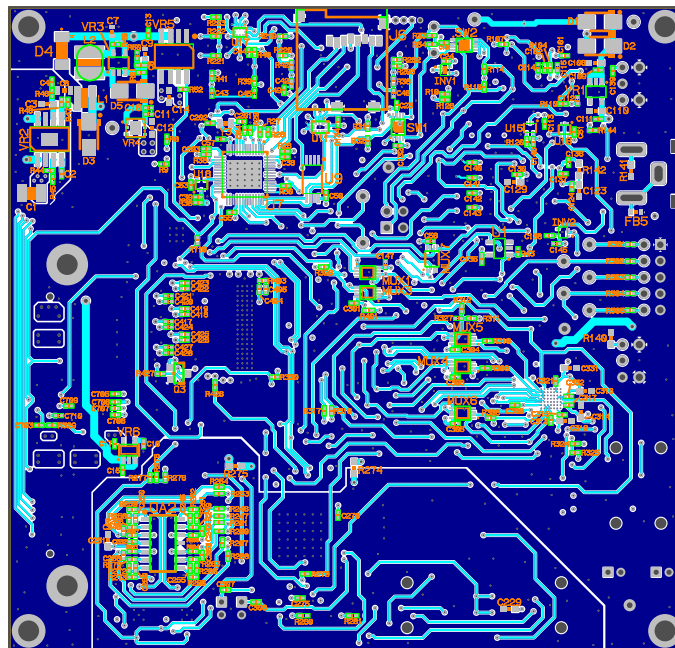

Figure 20. PurePath Console Motherboard, Revision F, Bottom Composite Assembly

4.3 Bill of Materials

Table 1 lists the bill of materials for the PPCMB, revision D.

Table 1. Bill of Materials, Revision D

ITEM	MANUFACTURER PART NUMBER	MANUFACTURER	QTY	REFERENCE DESIGNATORS	DESCRIPTION
1	TPS3825-33DBVR	TEXAS INSTRUMENTS	1	U1	PROCESSOR SUPERVISORY CIRCUITS 2.93V 200ms SOT23-DBV5 ROHS
2	TAS1020BPFB	TEXAS INSTRUMENTS	1	U2	USB STREAMING CONTROLLER TQFP48-PFB ROHS
3	PCM9211PTR	TEXAS INSTRUMENTS	1	U3	192kHz DIG AUDIO INTERFACE TRANSCEIVER W/STEREO ADC AND ROUTING LQFP48-PT ROHS
4	PCM3168APAP	TI/BURR-BROWN	1	U4	24 BIT 96/192kHz 6-IN 8-OUT CODEC DIFF IN/OUT HTQFP64-PAP ROHS
5	TLV320AIC3262IYZFR	TEXAS INSTRUMENTS	1	U5	CODEC WCSP81-YZF ROHS
6	TAS5548DCA	TEXAS INSTRUMENTS	1	U6	8 CHAN HD AUDIO PROCESSOR W/PWM OUTPUTS HTSSOP56-DCA ROHS
7	TCA6424ARGJR	TEXAS INSTRUMENTS	2	U7, U8	LOW-VOLTAGE 24 BIT .I2C EXPANDER W/RESET QFN32-RGJ ROHS
8	SN74LVC1G08DRLR	TEXAS INSTRUMENTS	2	AND1, AND4	SINGLE 2-INPUT POSITIVE-AND GATE SOT553-DRL6 ROHS
9	SN74LVC2G08DCTR	TEXAS INSTRUMENTS	2	AND2, AND3	DUAL 2-INPUT AND GATE TSSOP8-DCT ROHS
10	SN74LVC2G34DRLR	TEXAS INSTRUMENTS	6	BUF1, BUF2, BUF3, BUF4, BUF5, BUF6	DUAL BUFFER GATE SOT553-DRL6 ROHS
11	B360A-13-F	DIODES INC	1	CR1	SCHOTTKY BARRIER RECTIFIER 60V 3A SMA ROHS
12	ES2AA-13-F	DIODES INC	1	CR2	SUPER FAST RECTIFIER DIODE 50V 2A SMA ROHS
13	24LC512-I/ST	MICROCHIP	2	EP1, EP2	SERIAL EEPROM I2C 512K 400kHz TSSOP8-ST ROHS
14	SN74LVC1G14DRLR	TEXAS INSTRUMENTS	2	INV1, INV2	SINGLE INVERTER GATE SCHMITT-TRIGGER SOT553-DRL5 ROHS
15	TSOP34838	VISHAY	1	IR1	IR RECEIVER MODULE THRU 2.5-5V 38kHz TSOP348 SERIES ROHS
16	SML-P12YTT86	ROHM SEMICONDUCTOR	5	ET, OV, LED9, LED10, LED11	LED YELLOW SMD0402 2.1V 10mA ROHS
17	LB Q39G-L2N2-35-1	OSRAM OPTO	2	LED1, LED2	LED BLUE SMD0603 2.85V 5mA ROHS
18	LTST-C190YKT	LITE-ON INC.	2	LED3, LED4	LED YELLOW SMD0603 2.1V 10mA ROHS
19	LTST-C190EKT	LITE-ON INC.	1	LED5	LED RED SMD0603 2.1V 10mA ROHS
20	SML-P12UTT86	ROHM SEMICONDUCTOR	3	LED12, LED13, LED14	LED RED SMD0402 2.0V 10mA ROHS
21	SML-P12MTT86	ROHM SEMICONDUCTOR	3	3.3V, 5.0V, ZERO	LED GREEN SMD0402 2.1V 10mA ROHS
22	SMLP12BC7TT86	ROHM SEMICONDUCTOR	6	USB, LED6, LED7, LED8, LOCK, VALID	LED BLUE SMD0402 2.9V 10mA ROHS
23	MSP430F2132IPWR	TEXAS INSTRUMENTS	1	MCU	MIXED SIGNAL MICRO 8KB+256B FLASH 512B RAM TSSOP28-PW ROHS
24	SN74LVC2G157DCUR	TEXAS INSTRUMENTS	5	MUX1, MUX3, MUX4, MUX5, MUX6	MUX/DATA SELECTOR 2 TO 1 VSSOP8-DCU ROHS
25	TS3A27518ERTWR	TEXAS INSTRUMENTS	1	MUX2	6 BIT 1OF 2 MUX/DEMUX 1.8V COMPATIBLE QFN24-RTW ROHS
26	TLC27M4CPWR	TEXAS INSTRUMENTS	5	OA1, OA2, OA3, OA4, OA5	PRECISION QUAD OP AMP TSSOP14-PW ROHS
27	PLR135/T10	EVERLIGHT ELECTRONICS	1	OPTO-IN	PHOTOLINK FIBER OPTIC RECEIVER 2.4-5.5V 15MB PCB-RA SHUTTER ROHS
28	PLT133/T10W	EVERLIGHT ELECTRONICS	1	OPTO-OUT	PHOTOLINK FIBER OPTIC TRANSMITTER 2.4-5.5V 15MB PCB-RA SHUTTER ROHS
29	625L31006M00000	CTS FREQUENCY CONTROLS	2	OSC1, OSC2	OSCILLATOR SMT 6.0MHz 3.3V OUT-ENABLE ROHS
30	MMBT2222A-7-F	DIODES INC.	1	Q1	TRANSISTOR NPN GENERAL PURPOSE 40V 1A SOT23 DBV3 ROHS
31	DDTC114TCA-7-F	DIODES INC.	2	Q2, Q3	TRANSISTOR-NPN PREBIASED 10K SOT23-DBV3 ROHS
32	ACZ11BR1E-15KQA1-12C	CUI. INC.	1	S7	INCREMENTAL ENCODER ACZ11 SWITCH 12 POS 15mm KNURLED SHAFT ROHS
33	PCA9515ADGKR	TEXAS INSTRUMENTS	3	SW1, SW2, SW3	DUAL-BIDR I2C BUS AND SMB BUS REPEATER MSOP8-DGK ROHS
34	TPS73633DBVT	TEXAS INSTRUMENTS	1	VR1	VOLT REG 3.3V 400MA LDO CAP FREE NMOS SOT23-DBV5 ROHS

Table 1. Bill of Materials, Revision D (continued)

ITEM	MANUFACTURER PART NUMBER	MANUFACTURER	QTY	REFERENCE DESIGNATORS	DESCRIPTION
35	TPS54260DRCT	TEXAS INSTRUMENTS	1	VR2	2.5A 60V SETP DOWN SWIFT DC/DC CONV ECO MODE SON10-DRC ROHS
36	TPS78633DCQR	TEXAS INSTRUMENTS	1	VR3	LDO ULTRA LOW NOISE HIGH PSRR 3.3V 1.5A SOT23-DCQ ROHS
37	TPS73618DBVT	TEXAS INSTRUMENTS	1	VR4	VOLT REG 1.8V 400MA LDO CAP FREE NMOS SOT23-DBV5 ROHS
38	ABM10-24.576MHZ-E20-T	ABRACON	1	Y2	CRYSTAL SMT-ABM10 24.576MHz 4 PIN 10PFD FUNDAMENTAL ROHS
39	ABM8G-12.288MHZ-18-D2Y-T	ABRACOM	1	Y3	CRYSTAL SMD-ABM8G SERIES 12.288MHz 30ppm 18PFD ROHS
40	ECA-2AM220	PANASONIC	1	C1	CAP ALUM ELEC M RADIAL 22UF 100V 20% ROHS
41	C1608X7R2A153K	TDK	2	C2, C3	CAP SMD0603 CERM 0.015UF 100V 10% X7R ROHS
42	C1005X7R1H104K	TDK CORP	1	C4	CAP SMD0402 CERM 0.1ufd 50V 10% X7R ROHS
43	CC0402KRX7R8BB472	YAGEO	4	C5, C126, C402, C404	CAP SMD0402 CERM 4700pfd 25V 10% X7R ROHS
44	GRM1555C1H330JZ01D	MURATA	3	C6, C408, C409	CAP SMD0402 CERM 33PFD 5% 50V COG ROHS
45	GRM21BR61C106KE15L	MURATA	2	C7, C8	CAP SMD0805 CERM 10UF 16V 10% X5R ROHS
46	C1005X5R1A225K	TDK CORP	5	C9, C11, C15, C333, C334	CAP SMD0402 CERM 2.2UF 10V 10% X5R ROHS
47	0402YC103KAT2A	AVX	8	C10, C14, C206, C213, C220, C227, C506, C507	CAP SMD0402 CERM 0.01ufd 16V 10% X7R ROHS
48	GRM155R71C104KA88D	MURATA	82	C12, C13, C103, C107, C109, C112, C113, C114, C115, C116, C117, C118, C119, C120, C124, C128, C130, C131, C132, C133, C134, C135, C136, C137, C138, C139, C140, C141, C142, C143, C145, C146, C147, C201, C208, C215, C222, C230, C232, C234, C236, C262, C266, C267, C269, C270, C272, C273, C274, C275, C300, C301, C302, C304, C305, C306, C313, C315, C317, C319, C321, C323, C324, C326, C328, C330, C332, C338, C407, C410, C412, C413, C414, C416, C502, C504, C505, C508, C602, C603, C701, C702	CAP SMD0402 CERM 0.1UF 16V X7R 10% ROHS
49	500R07N470JV4T	JOHANSON	2	C101, C102	CAP SMD0402 CERM 47pfd 50V 5% COG ROHS
50	CC0402JRNPO9BN101	YAGEO	1	C105	CAP SMD0402 CERM 100pfd 50V 5% NPO ROHS
51	GRM1555C1H102JA01D	MURATA	1	C106	CAP SMD0402 CERM 1000pfd 5% 50V COG ROHS
52	C1608X5R1A106K	TDK CORP	44	C108, C110, C123, C127, C129, C200, C207, C214, C221, C229, C231, C233, C235, C237, C238, C239, C240, C241, C242, C246, C247, C251, C252, C256, C257, C261, C265, C268, C271, C314, C316, C318, C320, C322, C325, C327, C329, C331, C337, C406, C411, C415, C501, C503	CAP SMD0603 CERM 10ufd 10V 10% X5R ROHS
53	C1005X5R1A105K	TDK CORP	3	C111, C335, C336	CAP SMD0402 CERM 1.0UF 10V 10% X5R ROHS
54	GRM1555C1H270JZ01D	MURATA	2	C121, C122	CAP SMD0402 CERM 27PFD 5% 50V COG ROHS
55	CGA2B3X7R1H683K	TDK CORP	1	C125	CAP SMD0402 CERM 0.068ufd 50V 10% X7R ROHS
56	C0402C471K5RACTU	KEMET	8	C202, C203, C209, C210, C216, C217, C223, C224	CAP SMD0402 CERM 470PFD 50V 10% X7R ROHS
57	GRM155R71H332KA01D	MURATA	12	C204, C205, C211, C212, C218, C219, C225, C226, C243, C248, C253, C258	CAP SMD0402 CERM 3300PFD 10% 50V X7R ROHS
58	GRM1555C1H681JA01D	MURATA	8	C244, C245, C249, C250, C254, C255, C259, C260	CAP SMD0402 CERM 680PFD 5% 50V NPO ROHS
59	C1005X5R1E474K	TDK CORP	6	C307, C308, C309, C310, C311, C312	CAP SMD0402 CERM 0.47UF 25V 10% X5R ROHS
60	EMK105B7473KV-F	TAIYO YUDEN	2	C403, C405	CAP SMD0402 CERM 0.047UF 16V 10% X7R ROHS
61	RC0402FR-07124KL	YAGEO	1	R1	RESISTOR SMD0402 THICK FILM 124K OHMS 1% 1/16W ROHS
62	RMCF0402FT19K1	STACKPOLE ELECTRONICS	1	R2	RESISTOR SMD0402 19.1K OHMS 1% 1/16W ROHS
63	ERJ-2RKF7502X	PANASONIC	1	R3	RESISTOR SMD0402 THICK FILM 75K OHMS 1/10W 1% ROHS
64	CRCW040220K0FKED	VISHAY	1	R4	RESISTOR SMT 0402 1% 1/16W 20.0K ROHS
65	ERJ-2RKF6192X	PANASONIC	1	R5	RESISTOR SMD0402 THICK FILM 61.9K OHMS 1/10W 1% ROHS

Table 1. Bill of Materials, Revision D (continued)

ITEM	MANUFACTURER PART NUMBER	MANUFACTURER	QTY	REFERENCE DESIGNATORS	DESCRIPTION
66	CRCW040210K0FKED	VISHAY	15	R6, R7, R278, R407, R422, R502, R503, R504, R505, R506, R513, R514, R515, R516, R517	RESISTOR SMD0402 10.0K OHMS 1% 1/16W ROHS
67	RC0402FR-07511RL	YAGEO	1	R8	RESISTOR SMD0402 THICK FILM 511 OHMS 1% 1/16W ROHS
68	CRCW0402360RFKED	VISHAY	29	R9, R107, R144, R249, R250, R256, R257, R263, R264, R270, R271, R280, R281, R401, R427, R508, R509, R510, R511, R512, R701, R702, R703, R704, R705, R706, R707, R708, R709	RESISTOR SMD0402 360 1/16W 1% ROHS
69	RC0402FR-0747RL	YAGEO	48	R116, R117, R118, R119, R120, R153, R154, R155, R156, R157, R158, R159, R160, R206, R211, R216, R221, R226, R231, R236, R241, R252, R259, R266, R273, R279, R301, R302, R303, R304, R305, R306, R309, R310, R409, R410, R411, R412, R413, R414, R415, R416, R417, R418, R419, R420, R421, R426	RESISTOR SMD0402 THICK FILM 47.0 OHMS 1% 1/16W ROHS
70	RC0402FR-07200RL	YAGEO	2	R111, R507	RESISTOR SMD0402 THICK FILM 200 OHMS 1% 1/16W ROHS
71	RC0402FR-0715KL	YAGEO	2	R101, R405	RESISTOR SMD0402 THICK FILM 15.0K OHM 1% 1/16W ROHS
72	RMCF0402FT1K50	STACKPOLE ELECTRONICS	17	R102, R202, R203, R204, R209, R212, R213, R214, R219, R222, R223, R224, R229, R232, R233, R234, R239	RESISTOR SMD0402 1.50K OHMS 1% 1/16W ROHS
73	ERJ-2RKF27R4X	PANASONIC	5	R103, R104, R315, R322, R323	RESISTOR SMD0402 THICK FILM 27.4 OHMS 1/10W 1% ROHS
74	RC0402FR-073K09L	YAGEO	1	R105	RESISTOR SMD0402 THICK FILM 3.09K OHM 1% 1/16W ROHS
75	ERJ-2RKF1003X	PANASONIC	2	R106, R408	RESISTOR SMD0402 THICK FILM 100K OHMS 1/16W 1% ROHS
76	CRCW0402000Z0ED	VISHAY	20	R108, R112, R113, R121, R122, R123, R124, R126, R135, R136, R137, R138, R200, R201, R242, R243, R244, R326, R605, R710	ZERO OHM JUMPER SMT 0402 0 OHM 1/16W,5% ROHS
77	ERJ-2RKF4991X	PANASONIC	13	R110, R114, R115, R125, R128, R129, R130, R132, R139, R147, R148, R311, R606	RESISTOR SMD0402 4.99K 1%,1/16W ROHS
78	ERJ-2RKF2001X	PANASONIC	2	R133, R134	RESISTOR SMD0402 2.00K 1%,1/10W ROHS
79	ERJ-3EKF1002V	PANASONIC	1	R140	RESISTOR SMD0603 10.0K 1% THICK FILM 1/10W ROHS
80	CRCW060375R0FKEA	VISHAY	1	R141	RESISTOR SMD0603 75 OHMS 1% 1/10W ROHS
81	ERJ-3GEYJ1R0V	PANASONIC	1	R142	RESISTOR SMD0603 1.0 OHMS 1% THICK FILM 1/10W ROHS
82	RC0402FR-07680RL	YAGEO	1	R143	RESISTOR SMD0402 THICK FILM 680 OHMS 1% 1/16W ROHS
83	CRCW0402750RFKED	VISHAY	8	R205, R210, R215, R220, R225, R230, R235, R240	RESISTOR SMD0402 750 1/16W 1% ROHS
84	RC0402FR-074K7L	YAGEO	8	R207, R208, R217, R218, R227, R228, R237, R238	RESISTOR SMD0402 THICK FILM 4.70K OHMS 1% 1/16W ROHS
85	RC0402FR-077K5L	YAGEO	8	R246, R247, R253, R254, R260, R261, R267, R268	RESISTOR SMD0402 THICK FILM 7.50K OHM 1% 1/16W ROHS
86	ERJ-2RKF5601X	PANASONIC	8	R248, R251, R255, R258, R262, R265, R269, R272	RESISTOR SMD0402 5.60K 1/16W 1% ROHS
87	RMCF0603ZTOR00	STACKPOLE ELECTRONICS	6	R274, R275, R404, R601, R603, R604	RESISTOR SMD0603 ZERO OHMS 1/10W ROHS
88	ERJ-2RKF33R0X	PANASONIC	10	R307, R308, R313, R314, R316, R317, R318, R319, R320, R321	RESISTOR SMD0402 THICK FILM 33.0 OHMS 1/10W 1% ROHS
89	RC0402FR-072K21L	YAGEO	2	R324, R325	RESISTOR SMD0402 THICK FILM 2.21K OHMS 1% 1/16W ROHS
90	CRCW0603221RFKEA	VISHAY	1	R332	RESISTOR SMD0603 221 OHMS 1% 1/10W ROHS
91	ERJ-2RKF4700X	PANASONIC	2	R402, R403	RESISTOR SMD0402 THICK FILM 470 OHMS 1/10W 1% ROHS
92	RMCF0402FT1M00	STACKPOLE ELECTRONICS	1	R406	RESISTOR SMD0402 1.0M OHMS 1% 1/16W ROHS
93	MPZ1608S221A	TDK	5	FB1, FB2, FB3, FB4, FB11	FERRITE CHIP, 220 OHMS 2A 100MHZ SMD 0603 ROHS
94	1267AY-100M	TOKO JAPAN	1	L1	INDUCTOR SMT 10uH 3.3A 33 mOHMS 20% ROHS
95	QSS-050-01-F-D-A	SAMTEC	1	J1	CONNECTOR SMT/THU 100 POS+GND QSS SERIES ROHS
96	47346-0001	MOLEX	1	J2	JACK USB FEMALE TYPEB MICRO SMT-RA 5PIN ROHS
97	RCJ-2223	CUI STACK	2	AIN1, AIN2	RCA JACK DUAL THRU VERT RED OVER WHITE FEMALE ROHS

Table 1. Bill of Materials, Revision D (continued)

ITEM	MANUFACTURER PART NUMBER	MANUFACTURER	QTY	REFERENCE DESIGNATORS	DESCRIPTION
98	26630201RP2	NORCOMP	4	AIN3, AIN4, AOUT1, AOUT2	HEADER 2 PIN, PCB 2.0MM ROHS
99	PJРАН1X1U01X	SWITCHCRAFT	1	COAX	JACK, RCA 3-PIN PCB-RA BLACK ROHS
100	HLW30S-2C7LF	FCI	1	DisplayPort	CONNECTOR FLAT FLEX 1MM PCB 30 PIN ROHS
101	SJ-3523-SMT	CUI STACK	2	HP-IN, HP-OUT	JACK AUDIO-STEREO MINI(3.5MM ,3-COND SMT-RA ROHS
102	26641001RP2	NORCOMP	1	JTAG	HEADER 10 PIN 2x5 PCB 2.0MM ROHS
103	PBC03SAAN	SULLINS	4	MCLK, SCLK, SDIN, LRCLK	HEADER THRU MALE 3 PIN 100LS 120 TAIL GOLD ROHS
104	5003	KEYSTONE ELECTRONICS	2	SCL, SDA	PC TESTPOINT, ORANGE, ROHS
105	5001	KEYSTONE ELECTRONICS	2	GND, GND1	PC TESTPOINT, BLACK, ROHS
106	5000	KEYSTONE ELECTRONICS	1	+5V	PC TESTPOINT, RED, ROHS
107	TL1015AF160QG	E-SWITCH	6	S1, S2, S3, S4, S5, RESET	SWITCH, MOM, 160G SMT 4X3MM ROHS
ITEMS 108-110 ARE STANDOFFS AT THE CORNERS AND UNDER THE BOARD					
108	95947A018	MCMaster-CARR	4	STANDOFFS	STANDOFF M3x25mm 4.5mm DIA HEX ALUMINUM F-F ROHS
109	92000A118	MCMaster-CARR	4	STANDOFF HARDWARE	SCREW M3x8 PHILIPS PANHEAD STAINLESS STEEL ROHS
110	92148A150	MCMaster-CARR	4	STANDOFF HARDWARE	WASHER SPLIT-LOCK M3 6.2mm OD 0.7mm THICK STEEL ROHS
ITEMS 111-112 ARE MOUNTED ABOVE THE BOARD ON EACH SIDE OF J1.					
111	SO-0515-02-02	SAMTEC	2	J1 STANDOFFS	STANDOFF M3x0.5mm HEX 5mm LENGTH ALUMINUM M-M ROHS
112	96115A420	MCMaster-CARR	2	J1 HARDWARE	THUMBNUt M3x0.5x6mm BRASS ROHS
ITEMS 113-114 ARE MOUNTED BELOW THE BOARD TO HOLD ITEM 108 TO THE BOARD.					
113	91120A120	MCMaster-CARR	2	J1 HARDWARE	WASHER-LOCK EXT SERRATED M3 6mm OD 0.4mm THICK STEEL ROHS
114	91828A211	MCMaster-CARR	2	J1 HARDWARE	NUT HEX M3x0.5 2.4mm THICK STAINLESS STEEL ROHS
		TOTAL	548		
X1	DO NOT POPULATE		54	C417, C418, C419, C420, C421, C422, C423, C424, C425, C426, C427, C428, C501, C502, C506, C507, C602, C603, C703, C704, C705, C706, C707, C708, C709, C710, R109, R126, R127, R131, R145, R146, R276, R277, R312, R328, R423, R424, R425, R514, R515, R516, R517, R601, R602, R603, R604, R605, R606, DisplayPort, IR1, SW1, S7, U7	

Table 2 lists the bill of materials for the PPCMB, Revision E.

Table 2. Bill of Materials, Revision E

ITEM	MANUFACTURER PART NUMBER	MANUFACTURER	QTY	REFERENCE DESIGNATORS	DESCRIPTION
1	TPS3825-33DBVR	TEXAS INSTRUMENTS	1	U1	PROCESSOR SUPERVISORY CIRCUITS 2.93V 200ms SOT23-DBV5 ROHS
2	TAS1020BPFB	TEXAS INSTRUMENTS	1	U2	USB STREAMING CONTROLLER TQFP48-PFB ROHS
3	PCM9211PTR	TEXAS INSTRUMENTS	1	U3	192kHz DIG AUDIO INTERFACE TRANSCEIVER W/STEREO ADC AND ROUTING LQFP48-PT ROHS
4	PCM3168APAP	TI/BURR-BROWN	1	U4	24 BIT 96/192kHz 6-IN 8-OUT CODEC DIFF IN/OUT HTQFP64-PAP ROHS
5	TLV320AIC3262IYZFR	TEXAS INSTRUMENTS	1	U5	CODEC WCSP81-YZF ROHS
6	TAS5548DCA	TEXAS INSTRUMENTS	1	U6	8 CHAN HD AUDIO PROCESSOR W/PWM OUTPUTS HTSSOP56-DCA ROHS

Table 2. Bill of Materials, Revision E (continued)

ITEM	MANUFACTURER PART NUMBER	MANUFACTURER	QTY	REFERENCE DESIGNATORS	DESCRIPTION
7	TCA6424ARGJR	TEXAS INSTRUMENTS	2	U7, U8	LOW-VOLTAGE 24 BIT ,I2C EXPANDER W/RESET QFN32-RGJ ROHS
8	SN74LVC1G08DRLR	TEXAS INSTRUMENTS	2	AND1, AND4	SINGLE 2-INPUT POSITIVE-AND GATE SOT553-DRL6 ROHS
9	SN74LVC2G08DCRTR	TEXAS INSTRUMENTS	2	AND2, AND3	DUAL 2-INPUT AND GATE TSSOP8-DCT ROHS
10	SN74LVC2G34DRLR	TEXAS INSTRUMENTS	6	BUF1, BUF2, BUF3, BUF4, BUF5, BUF6	DUAL BUFFER GATE SOT553-DRL6 ROHS
11	B360A-13-F	DIODES INC	1	CR1	SCHOTTKY BARRIER RECTIFIER 60V 3A SMA ROHS
12	ES2AA-13-F	DIODES INC	1	CR2	SUPER FAST RECTIFIER DIODE 50V 2A SMA ROHS
13	24LC512-I/ST	MICROCHIP	2	EP1, EP2	SERIAL EEPROM I2C 512K 400kHz TSSOP8-ST ROHS
14	SN74LVC1G14DRLR	TEXAS INSTRUMENTS	2	INV1, INV2	SINGLE INVERTER GATE SCHMITT-TRIGGER SOT553-DRL5 ROHS
15	TSOP34838	VISHAY	1	IR1	IR RECEIVER MODULE THRU 2.5-5V 38kHz TSOP348 SERIES ROHS
16	SML-P12YTT86	ROHM SEMICONDUCTOR	5	ET, OVF, LED9, LED10, LED11	LED YELLOW SMD0402 2.1V 10mA ROHS
17	LB Q39G-L2N2-35-1	OSRAM OPTO	2	LED1, LED2	LED BLUE SMD0603 2.85V 5mA ROHS
18	LTST-C190YKT	LITE-ON INC.	2	LED3, LED4	LED YELLOW SMD0603 2.1V 10mA ROHS
19	LTST-C190EKT	LITE-ON INC.	1	LED5	LED RED SMD0603 2.1V 10mA ROHS
20	SML-P12UTT86	ROHM SEMICONDUCTOR	3	LED12, LED13, LED14	LED RED SMD0402 2.0V 10mA ROHS
21	SML-P12MTT86	ROHM SEMICONDUCTOR	3	3.3V, 5.0V, ZERO	LED GREEN SMD0402 2.1V 10mA ROHS
22	SMLP12BC7TT86	ROHM SEMICONDUCTOR	6	USB, LED6, LED7, LED8, LOCK, VALID	LED BLUE SMD0402 2.9V 10mA ROHS
23	MSP430F2132IPWR	TEXAS INSTRUMENTS	1	MCU	MIXED SIGNAL MICRO 8KB+256B FLASH 512B RAM TSSOP28-PW ROHS
24	SN74LVC2G157DCUR	TEXAS INSTRUMENTS	5	MUX1, MUX3, MUX4, MUX5, MUX6	MUX/DATA SELECTOR 2 TO 1 VSSOP8-DCU ROHS
25	TS3A27518ERTWR	TEXAS INSTRUMENTS	1	MUX2	6 BIT 1OF 2 MUX/DEMUX 1.8V COMPATIBLE QFN24-RTW ROHS
26	TLC27M4CPWR	TEXAS INSTRUMENTS	5	OA1, OA2, OA3, OA4, OA5	PRECISION QUAD OP AMP TSSOP14-PW ROHS
27	PLR135/T10	EVERLIGHT ELECTRONICS	1	OPTO-IN	PHOTOLINK FIBER OPTIC RECEIVER 2.4-5.5V 15MB PCB-RA SHUTTER ROHS
28	PLT133/T10W	EVERLIGHT ELECTRONICS	1	OPTO-OUT	PHOTOLINK FIBER OPTIC TRANSMITTER 2.4-5.5V 15MB PCB-RA SHUTTER ROHS
29	625L31006M00000	CTS FREQUENCY CONTROLS	2	OSC1, OSC2	OSCILLATOR SMT 6.0MHz 3.3V OUT-ENABLE ROHS
30	MMBT2222A-7-F	DIODES INC.	1	Q1	TRANSISTOR NPN GENERAL PURPOSE 40V 1A SOT23 DBV3 ROHS
31	DDTC114TCA-7-F	DIODES INC.	2	Q2, Q3	TRANSISTOR-NPN PREBIASED 10K SOT23-DBV3 ROHS
32	ACZ11BR1E-15KQA1-12C	CUI. INC.	1	S7	INCREMENTAL ENCODER ACZ11 SWITCH 12 POS 15mm KNURLED SHAFT ROHS
33	PCA9515BDGKR	TEXAS INSTRUMENTS	3	SW1, SW2, SW3	DUAL-BIDR I2C BUS AND SMB BUS REPEATER MSOP8-DGK ROHS
34	TPS73633DBVT	TEXAS INSTRUMENTS	1	VR1	VOLT REG 3.3V 400MA LDO CAP FREE NMOS SOT23-DBV5 ROHS
35	TPS54260DRCT	TEXAS INSTRUMENTS	1	VR2	2.5A 60V SETP DOWN SWIFT DC/DC CONV ECO MODE SON10-DRC ROHS
36	TPS78633DCQR	TEXAS INSTRUMENTS	1	VR3	LDO ULTRA LOW NOISE HIGH PSRR 3.3V 1.5A SOT23-DCQ ROHS
37	TPS73618DBVT	TEXAS INSTRUMENTS	1	VR4	VOLT REG 1.8V 400MA LDO CAP FREE NMOS SOT23-DBV5 ROHS
38	ABM10-24.576MHZ-E20-T	ABRACON	1	Y2	CRYSTAL SMT-ABM10 24.576MHz 4 PIN 10PPF FUNDAMENTAL ROHS
39	ABM8G-12.288MHZ-18-D2Y-T	ABRACOM	1	Y3	CRYSTAL SMD-ABM8G SERIES 12.288MHz 30ppm 18PPF ROHS
40	ECA-2AM220	PANASONIC	1	C1	CAP ALUM ELEC M RADIAL 22UF 100V 20% ROHS
41	C1608X7R2A153K	TDK	2	C2, C3	CAP SMD0603 CERM 0.015UF 100V 10% X7R ROHS
42	C1005X7R1H104K	TDK CORP	1	C4	CAP SMD0402 CERM 0.1uf 50V 10% X7R ROHS
43	CC0402KRX7R8BB472	YAGEO	4	C5, C126, C402, C404	CAP SMD0402 CERM 4700pfd 25V 10% X7R ROHS

Table 2. Bill of Materials, Revision E (continued)

ITEM	MANUFACTURER PART NUMBER	MANUFACTURER	QTY	REFERENCE DESIGNATORS	DESCRIPTION
44	GRM1555C1H330JZ01D	MURATA	3	C6, C408, C409	CAP SMD0402 CERM 33PFD 5% 50V COG ROHS
45	GRM21BR61C106K15L	MURATA	2	C7, C8	CAP SMD0805 CERM 10UFD 16V 10% X5R ROHS
46	C1005X5R1A225K	TDK CORP	5	C9, C11, C15, C333, C334	CAP SMD0402 CERM 2.2UFD 10V 10% X5R ROHS
47	0402YC103KAT2A	AVX	4	C10, C14, C506, C507	CAP SMD0402 CERM 0.01ufd 16V 10% X7R ROHS
48	GRM155R71C104KA88D	MURATA	82	C12, C13, C103, C107, C109, C112, C113, C114, C115, C116, C117, C118, C119, C120, C124, C128, C130, C131, C132, C133, C134, C135, C136, C137, C138, C139, C140, C141, C142, C143, C145, C146, C147, C201, C208, C215, C222, C230, C232, C234, C236, C262, C266, C267, C269, C270, C272, C273, C274, C275, C300, C301, C302, C304, C305, C306, C313, C315, C317, C319, C321, C323, C324, C326, C328, C330, C332, C338, C407, C410, C412, C413, C414, C416, C502, C504, C505, C508, C602, C603, C701, C702	CAP SMD0402 CERM 0.1UFD 16V X7R 10% ROHS
49	500R07N470JV4T	JOHANSON	2	C101, C102	CAP SMD0402 CERM 47pfd 50V 5% COG ROHS
50	CC0402JRNPO9BN101	YAGEO	1	C105	CAP SMD0402 CERM 100pfd 50V 5% NPO ROHS
51	GRM1555C1H102JA01D	MURATA	1	C106	CAP SMD0402 CERM 1000pfd 5% 50V COG ROHS
52	C1608X5R1A106K	TDK CORP	44	C108, C110, C123, C127, C129, C200, C207, C214, C221, C229, C231, C233, C235, C237, C238, C239, C240, C241, C242, C246, C247, C251, C252, C256, C257, C261, C265, C268, C271, C314, C316, C318, C320, C322, C325, C327, C329, C331, C337, C406, C411, C415, C501, C503	CAP SMD0603 CERM 10ufd 10V 10% X5R ROHS
53	C1005X5R1A105K	TDK CORP	3	C111, C335, C336	CAP SMD0402 CERM 1.0UFD 10V 10% X5R ROHS
54	GRM1555C1H270JZ01D	MURATA	2	C121, C122	CAP SMD0402 CERM 27PFD 5% 50V COG ROHS
55	CGA2B3X7R1H683K	TDK CORP	1	C125	CAP SMD0402 CERM 0.068ufd 50V 10% X7R ROHS
56	C0402C471K5RACTU	KEMET	8	C202, C203, C209, C210, C216, C217, C223, C224	CAP SMD0402 CERM 470PFD 50V 10% X7R ROHS
57	GRM155R71H332KA01D	MURATA	12	C204, C205, C211, C212, C218, C219, C225, C226, C243, C248, C253, C258	CAP SMD0402 CERM 3300PFD 10% 50V X7R ROHS
58	GRM1555C1H681JA01D	MURATA	8	C244, C245, C249, C250, C254, C255, C259, C260	CAP SMD0402 CERM 680PFD 5% 50V NPO ROHS
59	C1005X5R1E474K	TDK CORP	6	C307, C308, C309, C310, C311, C312	CAP SMD0402 CERM 0.47UFD 25V 10% X5R ROHS
60	EMK105B7473KV-F	TAIYO YUDEN	2	C403, C405	CAP SMD0402 CERM 0.047UFD 16V 10% X7R ROHS
61	RC0402FR-07124KL	YAGEO	1	R1	RESISTOR SMD0402 THICK FILM 124K OHMS 1% 1/16W ROHS
62	RMCF0402FT19K1	STACKPOLE ELECTRONICS	1	R2	RESISTOR SMD0402 19.1K OHMS 1% 1/16W ROHS
63	ERJ-2RKF7502X	PANASONIC	1	R3	RESISTOR SMD0402 THICK FILM 75K OHMS 1/10W 1% ROHS
64	CRCW040220K0FKED	VISHAY	1	R4	RESISTOR SMT 0402 1% 1/16W 20.0K ROHS
65	ERJ-2RKF6192X	PANASONIC	1	R5	RESISTOR SMD0402 THICK FILM 61.9K OHMS 1/10W 1% ROHS
66	CRCW040210K0FKED	VISHAY	15	R6, R7, R278, R407, R422, R502, R503, R504, R505, R506, R513, R514, R515, R516, R517	RESISTOR SMD0402 10.0K OHMS 1% 1/16W ROHS
67	RC0402FR-07511RL	YAGEO	1	R8	RESISTOR SMD0402 THICK FILM 511 OHMS 1% 1/16W ROHS
68	CRCW0402360RFKED	VISHAY	29	R9, R107, R144, R249, R250, R256, R257, R263, R264, R270, R271, R280, R281, R401, R427, R508, R509, R510, R511, R512, R701, R702, R703, R704, R705, R706, R707, R708, R709	RESISTOR SMD0402 360 1/16W 1% ROHS
69	RC0402FR-0747RL	YAGEO	48	R116, R117, R118, R119, R120, R153, R154, R155, R156, R157, R158, R159, R160, R206, R211, R216, R221, R226, R231, R236, R241, R252, R259, R266, R273, R279, R301, R302, R303, R304, R305, R306, R309, R310, R409, R410, R411, R412, R413, R414, R415, R416, R417, R418, R419, R420, R421, R426	RESISTOR SMD0402 THICK FILM 47.0 OHMS 1% 1/16W ROHS
70	RC0402FR-07200RL	YAGEO	2	R111, R507	RESISTOR SMD0402 THICK FILM 200 OHMS 1% 1/16W ROHS

Table 2. Bill of Materials, Revision E (continued)

ITEM	MANUFACTURER PART NUMBER	MANUFACTURER	QTY	REFERENCE DESIGNATORS	DESCRIPTION
71	RC0402FR-0715KL	YAGEO	2	R101, R405	RESISTOR SMD0402 THICK FILM 15.0K OHM 1% 1/16W ROHS
72	RMCF0402FT1K50	STACKPOLE ELECTRONICS	17	R102, R202, R203, R204, R209, R212, R213, R214, R219, R222, R223, R224, R229, R232, R233, R234, R239	RESISTOR SMD0402 1.50K OHMS 1% 1/16W ROHS
73	ERJ-2RKF27R4X	PANASONIC	5	R103, R104, R315, R322, R323	RESISTOR SMD0402 THICK FILM 27.4 OHMS 1/10W 1% ROHS
74	RC0402FR-073K09L	YAGEO	1	R105	RESISTOR SMD0402 THICK FILM 3.09K OHM 1% 1/16W ROHS
75	ERJ-2RKF1003X	PANASONIC	2	R106, R408	RESISTOR SMD0402 THICK FILM 100K OHMS 1/16W 1% ROHS
76	CRCW04020000Z0ED	VISHAY	21	R108, R112, R113, R121, R122, R123, R124, R126, R135, R136, R137, R138, R200, R201, R242, R243, R244, R312, R326, R605, R710	ZERO OHM JUMPER SMT 0402 0 OHM 1/16W,5% ROHS
77	ERJ-2RKF4991X	PANASONIC	13	R110, R114, R115, R125, R128, R129, R130, R132, R139, R147, R148, R311, R606	RESISTOR SMD0402 4.99K 1%,1/16W ROHS
78	ERJ-2RKF2001X	PANASONIC	2	R133, R134	RESISTOR SMD0402 2.00K 1%,1/10W ROHS
79	ERJ-3EKF1002V	PANASONIC	1	R140	RESISTOR SMD0603 10.0K 1% THICK FILM 1/10W ROHS
80	CRCW060375R0FKEA	VISHAY	1	R141	RESISTOR SMD0603 75 OHMS 1% 1/10W ROHS
81	ERJ-3GEYJ1R0V	PANASONIC	1	R142	RESISTOR SMD0603 1.0 OHMS 1% THICK FILM 1/10W ROHS
82	RC0402FR-07680RL	YAGEO	1	R143	RESISTOR SMD0402 THICK FILM 680 OHMS 1% 1/16W ROHS
83	CRCW0402750RFKED	VISHAY	8	R205, R210, R215, R220, R225, R230, R235, R240	RESISTOR SMD0402 750 1/16W 1% ROHS
84	RC0402FR-074K7L	YAGEO	8	R207, R208, R217, R218, R227, R228, R237, R238	RESISTOR SMD0402 THICK FILM 4.70K OHMS 1% 1/16W ROHS
85	RC0402FR-077K5L	YAGEO	8	R246, R247, R253, R254, R260, R261, R267, R268	RESISTOR SMD0402 THICK FILM 7.50K OHM 1% 1/16W ROHS
86	ERJ-2RKF5601X	PANASONIC	8	R248, R251, R255, R258, R262, R265, R269, R272	RESISTOR SMD0402 5.60K 1/16W 1% ROHS
87	RMCF0603ZT0R00	STACKPOLE ELECTRONICS	6	R274, R275, R404, R601, R603, R604	RESISTOR SMD0603 ZERO OHMS 1/10W ROHS
88	ERJ-2RKF33R0X	PANASONIC	10	R307, R308, R313, R314, R316, R317, R318, R319, R320, R321	RESISTOR SMD0402 THICK FILM 33.0 OHMS 1/10W 1% ROHS
89	RC0402FR-072K21L	YAGEO	2	R324, R325	RESISTOR SMD0402 THICK FILM 2.21K OHMS 1% 1/16W ROHS
90	CRCW0603221RFKEA	VISHAY	1	R332	RESISTOR SMD0603 221 OHMS 1% 1/10W ROHS
91	ERJ-2RKF4700X	PANASONIC	2	R402, R403	RESISTOR SMD0402 THICK FILM 470 OHMS 1/10W 1% ROHS
92	RMCF0402FT1M00	STACKPOLE ELECTRONICS	1	R406	RESISTOR SMD0402 1.0M OHMS 1% 1/16W ROHS
93	MPZ1608S221A	TDK	5	FB1, FB2, FB3, FB4, FB11	FERRITE CHIP, 220 OHMS 2A 100MHZ SMD 0603 ROHS
94	1267AY-100M	TOKO JAPAN	1	L1	INDUCTOR SMT 10uH 3.3A 33 mOHMS 20% ROHS
95	QSS-050-01-F-D-A	SAMTEC	1	J1	CONNECTOR SMT/THU 100 POS+GND QSS SERIES ROHS
96	47346-0001	MOLEX	1	J2	JACK USB FEMALE TYPEB MICRO SMT-RA 5PIN ROHS
97	RCJ-2223	CUI STACK	2	AIN1, AIN2	RCA JACK DUAL THRU VERT RED OVER WHITE FEMALE ROHS
98	26630201RP2	NORCOMP	4	AIN3, AIN4, AOUT1, AOUT2	HEADER 2 PIN, PCB 2.0MM ROHS
99	PJRN1X1U01X	SWITCHCRAFT	1	COAX	JACK, RCA 3-PIN PCB-RA BLACK ROHS
100	HLW30S-2C7LF	FCI	1	DisplayPort	CONNECTOR FLAT FLEX 1MM PCB 30 PIN ROHS
101	SJ-3523-SMT	CUI STACK	2	HP-IN, HP-OUT	JACK AUDIO-STEREO MINI(3.5MM) ,3-COND SMT-RA ROHS
102	26641001RP2	NORCOMP	1	JTAG	HEADER 10 PIN 2x5 PCB 2.0MM ROHS
103	PBC03SAAN	SULLINS	4	MCLK, SCLK, SDIN, LRCLK	HEADER THRU MALE 3 PIN 100LS 120 TAIL GOLD ROHS
104	5003	KEYSTONE ELECTRONICS	2	SCL, SDA	PC TESTPOINT, ORANGE, ROHS
105	5001	KEYSTONE ELECTRONICS	2	GND, GND1	PC TESTPOINT, BLACK, ROHS

Table 2. Bill of Materials, Revision E (continued)

ITEM	MANUFACTURER PART NUMBER	MANUFACTURER	QTY	REFERENCE DESIGNATORS	DESCRIPTION
106	5000	KEystone ELECTRONICS	1	+5V	PC TESTPOINT, RED, ROHS
107	TL1015AF160QG	E-SWITCH	6	S1, S2, S3, S4, S5, RESET	SWITCH, MOM, 160G SMT 4X3MM ROHS
ITEMS 108-110 ARE STANDOFFS AT THE CORNERS AND UNDER THE BOARD					
108	95947A018	MCMaster-CARR	4	STANDOFFS	STANDOFF M3x25mm 4.5mm DIA HEX ALUMINUM F-F ROHS
109	92000A118	MCMaster-CARR	4	STANDOFF HARDWARE	SCREW M3x8 PHILIPS PANHEAD STAINLESS STEEL ROHS
110	92148A150	MCMaster-CARR	4	STANDOFF HARDWARE	WASHER SPLIT-LOCK M3 6.2mm OD 0.7mm THICK STEEL ROHS
ITEMS 111-112 ARE MOUNTED ABOVE THE BOARD ON EACH SIDE OF J1.					
111	SO-0515-02-02	SAMTEC	2	J1 STANDOFFS	STANDOFF M3x0.5mm HEX 5mm LENGTH ALUMINUM M-M ROHS
112	96115A420	MCMaster-CARR	2	J1 HARDWARE	THUMBNUt M3x0.5x6mm BRASS ROHS
ITEMS 113-114 ARE MOUNTED BELOW THE BOARD TO HOLD ITEM 108 TO THE BOARD.					
113	91120A120	MCMaster-CARR	2	J1 HARDWARE	WASHER-LOCK EXT SERRATED M3 6mm OD 0.4mm THICK STEEL ROHS
114	91828A211	MCMaster-CARR	2	J1 HARDWARE	NUT HEX M3x0.5 2.4mm THICK STAINLESS STEEL ROHS
		TOTAL	548		
X1	DO NOT POPULATE		57	C206, C213, C220, C227, C417, C418, C419, C420, C421, C422, C423, C424, C425, C426, C427, C428, C501, C502, C506, C507, C602, C603, C703, C704, C705, C706, C707, C708, C709, C710, R109, R126, R127, R131, R145, R146, R276, R277, R328, R423, R424, R425, R514, R515, R516, R517, R601, R602, R603, R604, R605, R606, DisplayPort, IR1, SW1, S7, U7	

Table 3 lists the bill of materials for the PPCMB, Revision F.

Table 3. Bill of Materials, Revisions F

ITEM	MANUFACTURER PART NUMBER	MANUFACTURER	QTY	REFERENCE DESIGNATORS	DESCRIPTION
1	TPS3825-33DBVR	TEXAS INSTRUMENTS	1	U1	PROCESSOR SUPERVISORY CIRCUITS 2.93V 200ms SOT23-DBV5 ROHS
2	TAS1020BPFB	TEXAS INSTRUMENTS	1	U2	USB STREAMING CONTROLLER TQFP48-PFB ROHS
3	PCM9211PTR	TEXAS INSTRUMENTS	1	U3	192kHz DIG AUDIO TRANSCEIVER W/STEREO ADC AND ROUTING LQFP48-PT ROHS
4	PCM3168APAP	TI/BURR-BROWN	1	U4	24 BIT 96/192kHz 6-IN 8-OUT CODEC DIFF IN/OUT HTQFP64-PAP ROHS
5	TLV320AIC3262IYZFR	TEXAS INSTRUMENTS	1	U5	CODEC WCS81-YZF ROHS
6	TAS5548DCA	TEXAS INSTRUMENTS	1	U6	8 CHAN HD AUDIO PROCESSOR W/PWM OUTPUTS HTSSOP56-DCA ROHS
7	MSP430F5510IRGZR	TEXAS INSTRUMENTS	1	U7	MIXED SIGNAL MICROCONTROLLER QFN48-RGZ ROHS
8	TCA6424ARGJR	TEXAS INSTRUMENTS	1	U8	LOW-VOLTAGE 24 BIT .I2C EXPANDER W/RESET QFN32-RGJ ROHS
9	24LC512-I/ST	MICROCHIP	2	U9, EP1	SERIAL EEPROM I2C 512K 400kHz TSSOP8-ST ROHS
10	TCA6408ARSVR	TEXAS INSTRUMENTS	1	U11	LO VOLT 8 BIT I2C EXPANDER INTERRUPT RESET UQFN16-RSV,ROHS
11	SN74LVC1G125DRLR	TEXAS INSTRUMENTS	6	U12, U13, U14, U15, U16, U18	SINGLE BUS BUFFER GATE WITH 3-STATE OUTPUT SOT553-DRL5 ROHS
12	TCA6507RUE	TEXAS INSTRUMENTS	1	U17	7-BIT I2C/SMBUS LED DRIVER W/SHUTDOWN QFN12-RUE ROHS
13	AT45DB041E-MHN2B-T	ADESTO TECHNOLOGIES	1	U19	DATAFLASH MEMORY 4MB SPI CONTROL UDFN8 ROHS
14	LB Q39G-L2N2-35-1	OSRAM OPTO	2	A, PROF-A	LED BLUE SMD0603 2.85V 5mA ROHS
15	LTST-C190EKT	LITE-ON INC.	2	B, PROF-B	LED RED SMD0603 2.1V 10mA ROHS

Table 3. Bill of Materials, Revisions F (continued)

ITEM	MANUFACTURER PART NUMBER	MANUFACTURER	QTY	REFERENCE DESIGNATORS	DESCRIPTION
16	SN74LVC2G34DRLR	TEXAS INSTRUMENTS	5	BUF1, BUF2, BUF3, BUF4, BUF5	DUAL BUFFER GATE SOT553-DRL6 ROHS
17	ES2AA-13-F	DIODES INC	2	D1, D2	SUPER FAST RECTIFIER DIODE 50V 2A SMA ROHS
18	B360A-13-F	DIODES INC	2	D3, D5	SCHOTTKY BARRIER RECTIFIER 60V 3A SMA ROHS
19	CMS01(TE12L,Q,M)	TOSHIBA	1	D4	SCHOTTKY DIODE 30V 3A SOD-128_M-FLAT ROHS
20	SML-P12YTT86	ROHM SEMICONDUCTOR	2	ET, OVf	LED YELLOW SMD0402 2.1V 10mA ROHS
21	SN74LVC1G14DRLR	TEXAS INSTRUMENTS	2	INV1, INV2	SINGLE INVERTER GATE SCHMITT-TRIGGER SOT553-DRL5 ROHS
22	SN74LVC2G157DCUR	TEXAS INSTRUMENTS	7	MUX1, MUX3, MUX4, MUX5, MUX6, MUX7, MUX8	MUX/DATA SELECTOR 2 TO 1 VSSOP8-DCU ROHS
23	LMS4684LD/NOPB	TEXAS INSTRUMENTS	2	MUX2A, MUX2B	DUAL SPDT ANALOG SWITCH 0.5 OHM LO-VOLT WSON10-NGZ ROHS
24	OPA4134UA	TEXAS INSTRUMENTS	2	OA1, OA2	SOUNDPASS HI-PERF QUAD AUDIO OP AMP SOP14-D ROHS
25	PLR135/T10	EVERLIGHT ELECTRONICS	1	OPTO-IN	PHOTOLINK FIBER OPTIC RECEIVER 2.4-5.5V 15MB PCB-RA SHUTTER ROHS
26	PLT133/T10W	EVERLIGHT ELECTRONICS	1	OPTO-OUT	PHOTOLINK FIBER OPTIC TRANSMITTER 2.4-5.5V 15MB PCB-RA SHUTTER ROHS
27	625L31006M00000	CTS FREQUENCY CONTROLS	1	OSC1	OSCILLATOR SMT 6.0MHz 3.3V OUT-ENABLE ROHS
28	MMBT2222A-7-F	DIODES INC.	1	Q1	TRANSISTOR NPN GENERAL PURPOSE 40V 1A SOT23-DBV3 ROHS
29	DDTC114TCA-7-F	DIODES INC.	2	Q2, Q3	TRANSISTOR-NPN PREBIASED 10K SOT23-DBV3 ROHS
30	TCA9406DCUR	TEXAS INSTRUMENTS	3	SW1, SW2, SW3	IC LVL-TRANSL I2C BUS REP,US8-DCU,ROHS
31	LNJ037X8ARA	PANASONIC	3	USB, ANALOG, OPTICAL	LED, WHITE 2.9V SMD0805 ROHS
32	SMLP12BC7TT86	ROHM SEMICONDUCTOR	3	VALID, USB-LOCK, SPDIF-LOCK	LED BLUE SMD0402 2.9V 10mA ROHS
33	TPS73633DBVT	TEXAS INSTRUMENTS	1	VR1	VOLT REG 3.3V 400MA LDO CAP FREE NMOS SOT23-DBV5 ROHS
34	TPS54332DDA	TEXAS INSTRUMENTS	1	VR2	DC-DC CONVERTER 3.5A 28V 1MHz ECO-MODE SO8-DDA ROHS
35	LMR62421XMFE/NOPB	TEXAS INSTRUMENTS	1	VR3	VOLT-REG STEP-UP SIMPLE SWITCHER 24V OUT 2.1A SOT23-DBV5 ROHS
36	LP38690SD-5.0/NOPB	TEXAS INSTRUMENTS	1	VR4	VOLT REG LDO 5V 1A VIN=2.7-10V WSON6-NGG0006A ROHS
37	TPS76833QD	TEXAS INSTRUMENTS	1	VR5	VOLT REG LDO 3.3V 1A VIN=2.7-10V SOP8-D ROHS
38	TPS73618DBVT	TEXAS INSTRUMENTS	1	VR6	VOLT REG 1.8V 400MA LDO CAP FREE NMOS SOT23-DBV5 ROHS
39	ABM10-24.576MHZ-E20-T	ABRACON	1	Y1	CRYSTAL SMT-ABM10 24.576MHz 4 PIN 10PFD FUNDAMENTAL ROHS
40	ABM8G-12.288MHZ-18-D2Y-T	ABRACOM	1	Y2	CRYSTAL SMD-ABM8G SERIES 12.288MHz 30ppm 18PFD ROHS
41	TF202P32K7680	CTS	1	Y3	CRYSTAL SMD0805 TF20 SERIES 32.768KHz 20ppm 12PFD ROHS
42	SML-P12MTT86	ROHM SEMICONDUCTOR	3	3.3V, 5.0V, ZERO	LED GREEN SMD0402 2.1V 10mA ROHS
43	C1210X475K5RACTU	KEMET	1	C1	CAP SMD1210 CERM 4.7UFd 50V 10% X7R ROHS
44	GRM155R71E822KA01D	MURATA	1	C2	CAP SMD0402 CERM 8200PFd 10% 25V X7R ROHS
45	C0603C270J5GACTU	KEMET	1	C3	CAP SMD0603 CERM 27PFd 50V 5% NPO ROHS
46	GRM1555C1H102JA01D	MURATA	2	C4, C106	CAP SMD0402 CERM 1000pfd 5% 50V COG ROHS
47	C1005X7R1H104M050BB	TDK CORP	1	C5	CAP SMD0402 CERM 0.1ufd 50V 20% X7R ROHS
48	C2012X5R0J226M	TDK	1	C6	CAP SMD0805 CERM 22UFd 6.3V 20% X5R ROHS
49	C1608X5R1A106K	TDK CORP	40	C7, C9, C12, C14, C108, C110, C123, C127, C129, C200, C207, C214, C221, C229, C231, C237, C238, C239, C240, C241, C242, C246, C247, C251, C252, C256, C257, C265, C268, C271, C314, C316, C318, C320, C322, C331, C337, C406, C411, C415	CAP SMD0603 CERM 10ufd 10V 10% X5R ROHS
50	GRM1555C1H681JA01D	MURATA	10	C8, C38, C244, C245, C249, C250, C254, C255, C259, C260	CAP SMD0402 CERM 680PFd 5% 50V NPO ROHS

Table 3. Bill of Materials, Revisions F (continued)

ITEM	MANUFACTURER PART NUMBER	MANUFACTURER	QTY	REFERENCE DESIGNATORS	DESCRIPTION
51	C1005X5R1A105K	TDK CORP	4	C10, C111, C335, C336	CAP SMD0402 CERM 1.0UFD 10V 10% X5R ROHS
52	GRM155R71C104KA88J	MURATA	93	C11, C13, C15, C18, C19, C20, C21, C22, C23, C24, C37, C39, C40, C41, C42, C43, C44, C45, C46, C48, C49, C50, C51, C52, C53, C54, C55, C56, C57, C58, C103, C107, C109, C112, C113, C114, C115, C116, C117, C118, C119, C120, C124, C128, C130, C131, C132, C133, C134, C135, C136, C137, C138, C139, C140, C141, C142, C143, C145, C146, C147, C230, C232, C266, C267, C269, C270, C272, C273, C274, C275, C300, C301, C304, C305, C306, C313, C315, C317, C319, C321, C323, C324, C332, C338, C407, C410, C412, C413, C414, C416, C701, C702	CAP SMD0402 CERM 0.1UFD 16V X7R 10% ROHS
53	0402YC103KAT2A	AVX	1	C16	CAP SMD0402 CERM 0.01ufd 16V 10% X7R ROHS
54	C1005X5R1A225K	TDK CORP	3	C17, C333, C334	CAP SMD0402 CERM 2.2UFD 10V 10% X5R ROHS
55	C1005X7R1H222K	TDK CORP.	4	C25, C28, C31, C34	CAP SMD0402 CERM 2200PFD 50V 10% X7R ROHS
56	GRM155R71C223KA01D	MURATA	8	C26, C27, C29, C30, C32, C33, C35, C36	CAP SMD0402 CERM 0.022UFD 16V X7R 10% ROHS
57	500R07N470JV4T	JOHANSON	2	C101, C102	CAP SMD0402 CERM 47pfd 50V 5% COG ROHS
58	CC0402JRNPO9BN101	YAGEO	1	C105	CAP SMD0402 CERM 100pfd 50V 5% NPO ROHS
59	GRM1555C1H270JA01D	MURATA	2	C121, C122	CAP SMD0402 CERM 27PFD 5% 50V COG ROHS
60	CGA2B3X7R1H683K	TDK CORP	1	C125	CAP SMD0402 CERM 0.068ufd 50V 10% X7R ROHS
61	CC0402KRX7R8BB472	YAGEO	3	C126, C402, C404	CAP SMD0402 CERM 4700pfd 25V 10% X7R ROHS
62	GRM1555C1H120JZ01D	MURATA	2	C201, C202	CAP SMD0402 CERM 12PFD 50V NPO 5% ROHS
63	C1005X5R0J224	TDK CORP	1	C203	CAP SMD0402 CERM 0.22UFD 6.3V 10% X5R ROHS
64	GRM155R71H332KA01D	MURATA	4	C243, C248, C253, C258	CAP SMD0402 CERM 3300PFD 10% 50V X7R ROHS
65	C1005X5R1E474K	TDK CORP	6	C307, C308, C309, C310, C311, C312	CAP SMD0402 CERM 0.47UFD 25V 10% X5R ROHS
66	EMK105B7473KV-F	TAIYO YUDEN	2	C403, C405	CAP SMD0402 CERM 0.047UFD 16V 10% X7R ROHS
67	GRM1555C1H330JA01D	MURATA	2	C408, C409	CAP SMD0402 CERM 33pF 5% 50V COG ROHS
68	RC0402FR-073K09L	YAGEO	5	R1, R4, R7, R13, R105	RESISTOR SMD0402 THICK FILM 3.09K OHM 1% 1/16W ROHS
69	RMCF0402FT1K50	STACKPOLE ELECTRONICS	8	R2, R5, R11, R14, R102, R221, R222, R223	RESISTOR SMD0402 1.50K OHMS 1% 1/16W ROHS
70	RC0402FR-0747RL	YAGEO	38	R3, R6, R12, R15, R116, R117, R118, R120, R153, R154, R155, R156, R157, R158, R159, R160, R252, R259, R266, R273, R279, R306, R309, R310, R409, R410, R411, R412, R413, R414, R415, R416, R417, R418, R419, R420, R421, R426	RESISTOR SMD0402 THICK FILM 47.0 OHMS 1% 1/16W ROHS
71	RC0402FR-07511RL	YAGEO	1	R8	RESISTOR SMD0402 THICK FILM 511 OHMS 1% 1/16W ROHS
72	CRCW0402360RFKED	VISHAY	15	R9, R107, R144, R249, R250, R256, R257, R263, R264, R270, R271, R280, R281, R401, R427	RESISTOR SMD0402 360 1/16W 1% ROHS
73	RC0402FR-074K7L	YAGEO	3	R114, R115, R128	RESISTOR SMD0402 THICK FILM 4.70K OHMS 1% 1/16W ROHS
74	RC0402FR-07200KL	YAGEO	8	R16, R17, R18, R19, R22, R23, R24, R25	RESISTOR SMD0402 THICK FILM 200K OHMS 1% 1/16W ROHS
75	RMCF0603ZTOR00	STACKPOLE ELECTRONICS	5	R20, R21, R274, R275, R404	RESISTOR SMD0603 ZERO OHMS 1/10W ROHS
76	RMCF0402FT47K0	STACKPOLE ELECTRONICS	10	R26, R27, R28, R36, R38, R39, R40, R41, R42, R43	RESISTOR SMD0402 47.0K OHMS 1% 1/16W ROHS
77	CRCW040210K0FKED	VISHAY	7	R29, R35, R49, R50, R278, R407, R422	RESISTOR SMD0402 10.0K OHMS 1% 1/16W ROHS
78	RMCF0402FT1M00	STACKPOLE ELECTRONICS	2	R30, R406	RESISTOR SMD0402 1.0M OHMS 1% 1/16W ROHS
79	RC0402FR-072K21L	YAGEO	4	R31, R32, R324, R325	RESISTOR SMD0402 THICK FILM 2.21K OHMS 1% 1/16W ROHS
80	CRCW0402169KFKED	VISHAY	1	R44	RESISTOR SMD0402 169K OHMS 1% 1/16W ROHS

Table 3. Bill of Materials, Revisions F (continued)

ITEM	MANUFACTURER PART NUMBER	MANUFACTURER	QTY	REFERENCE DESIGNATORS	DESCRIPTION
81	CRCW040273K2FKED	VISHAY	1	R45	RESISTOR SMD0402 73.2K OHMS 1% 1/16W ROHS
82	CRCW040226K7FKED	VISHAY	1	R46	RESISTOR SMT 0402 1% 1/16W 26.7K ROHS
83	CRCW040210K2FKED	VISHAY	1	R47	RESISTOR SMD0402 10.2K OHMS 1% 1/16W ROHS
84	CRCW04022K43FKED	VISHAY	1	R48	RESISTOR SMD0402 2.43K 1/16W 1% ROHS
85	CRCW040234K0FKED	VISHAY	1	R51	RESISTOR SMT 0402 34.0K OHMS 1% 1/16W ROHS
86	RC0402FR-07249KL	PANASONIC	1	R52	RESISTOR SMD0402 THICK FILM 249K OHMS 1/10W 1% ROHS
87	RC0402FR-0715KL	YAGEO	2	R101, R405	RESISTOR SMD0402 THICK FILM 15.0K OHM 1% 1/16W ROHS
88	ERJ-2RKF27R4X	PANASONIC	10	R103, R104, R301, R302, R303, R304, R305, R315, R322, R323	RESISTOR SMD0402 THICK FILM 27.4 OHMS 1/10W 1% ROHS
89	ERJ-2RKF1003X	PANASONIC	1	R106	RESISTOR SMD0402 THICK FILM 100K OHMS 1/16W 1% ROHS
90	ERJ-2RKF4991X	PANASONIC	5	R110, R139, R147, R148, R311	RESISTOR SMD0402 4.99K 1%,1/16W ROHS
91	ERJ-3EKF1002V	PANASONIC	1	R140	RESISTOR SMD0603 10.0K 1% THICK FILM 1/10W ROHS
92	CRCW060375R0FKEA	VISHAY	1	R141	RESISTOR SMD0603 75 OHMS 1% 1/10W ROHS
93	ERJ-3GEYJ1R0V	PANASONIC	1	R142	RESISTOR SMD0603 1.0 OHMS 1% THICK FILM 1/10W ROHS
94	RC0402FR-07680RL	YAGEO	1	R143	RESISTOR SMD0402 THICK FILM 680 OHMS 1% 1/16W ROHS
95	CRCW04020000Z0ED	VISHAY	9	R200, R201, R242, R243, R244, R277, R312, R326, R710	ZERO OHM JUMPER SMT 0402 0 OHM 1/16W,5% ROHS
96	ERJ-2RKF1001X	PANASONIC	2	R202, R219	RESISTOR SMD0402 1.00K 1%,1/16W ROHS
97	RC0402FR-07200RL	YAGEO	2	R203, R220	RESISTOR SMD0402 THICK FILM 200 OHMS 1% 1/16W ROHS
98	RC0402FR-077K5L	YAGEO	8	R246, R247, R253, R254, R260, R261, R267, R268	RESISTOR SMD0402 THICK FILM 7.50K OHM 1% 1/16W ROHS
99	ERJ-2RKF5601X	PANASONIC	8	R248, R251, R255, R258, R262, R265, R269, R272	RESISTOR SMD0402 5.60K 1/16W 1% ROHS
100	ERJ-2RKF33R0X	PANASONIC	12	R307, R308, R313, R314, R316, R317, R318, R319, R320, R321, R329, R330	RESISTOR SMD0402 THICK FILM 33.0 OHMS 1/10W 1% ROHS
101	CRCW0603221RFKEA	VISHAY	1	R332	RESISTOR SMD0603 221 OHMS 1% 1/10W ROHS
102	ERJ-2RKF4700X	PANASONIC	2	R402, R403	RESISTOR SMD0402 THICK FILM 470 OHMS 1/10W 1% ROHS
103	XAL4030-682MEB	COIL CRAFT	1	L1	SHIELDED POWER INDUCTOR 6.8uH 3.6A ROHS
104	SDR0403-2R2ML	BOURNS	1	L2	POWER INDUCTOR SMT 2.2uH 2.6A 47mOHMS ROHS
105	MPZ1608S221A	TDK	5	FB1, FB2, FB3, FB4, FB5	FERRITE CHIP, 220 OHMS 2A 100MHZ SMD 0603 ROHS
106	SJ-3523-SMT	CUI STACK	4	AIN1, AIN2, HP-OUT, MIC-IN	JACK AUDIO-STEREO MINI(3.5MM),3-COND SMT-RA ROHS
107	26630201RP2	NORCOMP	4	AIN3, AIN4, AOUT1, AOUT2	HEADER 2 PIN, PCB 2.0MM ROHS
108	PJ-RAN1X1U01X	SWITCHCRAFT	1	COAX	JACK, RCA 3-PIN PCB-RA BLACK ROHS
109	QSS-050-01-F-D-A	SAMTEC	1	J1	CONNECTOR SMT/THU 100 POS+GND QSS SERIES ROHS
110	47346-0001	MOLEX	1	J2	JACK USB FEMALE TYPEB MICRO SMT-RA 5PIN ROHS
111	PBC02DAAN	SULLINS	1	J3	HEADER THRU MALE 2X2 PIN 100LS 120 TAIL GOLD ROHS
112	PBC05DAAN	SULLINS	1	J4	HEADER THRU MALE 2X5 PIN 100LS 120 TAIL GOLD ROHS
113	851-43-004-20-001000	MILL-MAX	1	J5	SOCKET HEADER 1x4 FEMALE-RA 50LS ROHS
114	2908-05WB-MG	3M	1	J6	CONNECTOR MICROSD-SMD PUSH-PUSH SERIES 2900 ROHS
115	5001	KEYSTONE ELECTRONICS	3	GND, GND1, GND2	PC TESTPOINT, BLACK, ROHS
116	5003	KEYSTONE ELECTRONICS	7	DIN, SCL, SDA, BCLK, DOUT, LRCK, MCLK	PC TESTPOINT, ORANGE, ROHS
117	5000	KEYSTONE ELECTRONICS	3	4V, +5V, +5V-USB	PC TESTPOINT, RED, ROHS

Table 3. Bill of Materials, Revisions F (continued)

ITEM	MANUFACTURER PART NUMBER	MANUFACTURER	QTY	REFERENCE DESIGNATORS	DESCRIPTION
118	TL1015AF160QG	E-SWITCH	6	MODE, VOL+, VOL-, INPUT, RESET, PROFILE	SWITCH, MOM, 160G SMT 4X3MM ROHS
ITEMS 108-110 ARE STANDOFFS AT THE CORNERS AND UNDER THE BOARD					
119	24438	KEYSTONE ELECTRONICS	4	STANDOFFS (NO SUBSTITUTES ALLOWED)	STANDOFF M3x25mm 5mm DIA HEX ALUM F-F ROHS
120	RM3X8MM 2701	APM-HEXSEAL	4	STANDOFF HARDWARE	SCREW M3x8 PHILIPS PANHEAD STAINLESS STEEL ROHS
ITEMS 111-112 ARE MOUNTED ABOVE THE BOARD ON EACH SIDE OF J1.					
121	SO-0515-02-02	SAMTEC	2	J1 STANDOFFS (NO SUBSTITUTES ALLOWED)	STANDOFF M3x0.5mm HEX 5mm LENGTH ALUMINUM M-M ROHS
122	96115A420	MCMaster-CARR	2	J1 HARDWARE	THUMBNUt M3x0.5x6mm BRASS ROHS
ITEMS 113-114 ARE MOUNTED BELOW THE BOARD TO HOLD ITEM 108 TO THE BOARD.					
123	5205820-3	TE CONNECTIVITY	2	J1 HARDWARE	WASHER FLAT #4 0.219" OD 0.032" THICK STEEL ROHS
124	M3-HFST-Z100-	DURATOOL	2	J1 HARDWARE	NUT HEX M3 2.4mm THICK STEEL ROHS
		TOTAL	507		
X1	DO NOT POPULATE		46	C417, C418, C419, C420, C421, C422, C423, C424, C425, C426, C427, C428, C703, C705, C706, C707, C708, C709, C710, HPL+, HPR+, LRCKO, MCLKO, P1+, P1-, P2+, P2-, P3+, P3-, P4+, P4-, P5+, P6+, P7+, P7-, P8+, P8-, R10, R33, R34, R276, R327, R328, SCKO, SDOUT-5548, VLD	

4.4 PurePath Console, Revision D and E, Schematic

Figure 21 through Figure 30 show the schematics for the PurePath Console, revisions D and E.

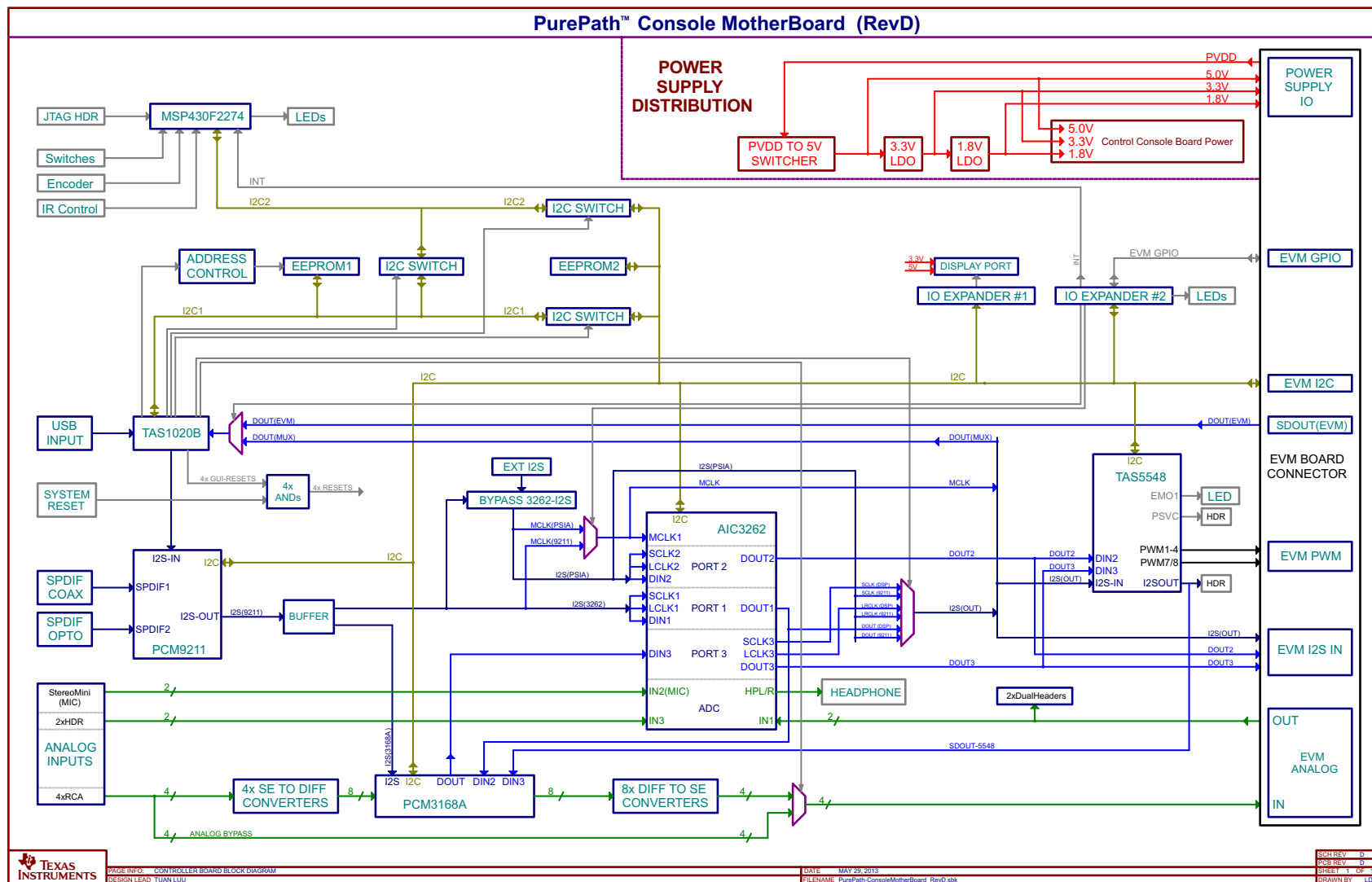

Figure 21. PurePath Console Revisions D and E (1 of 10)

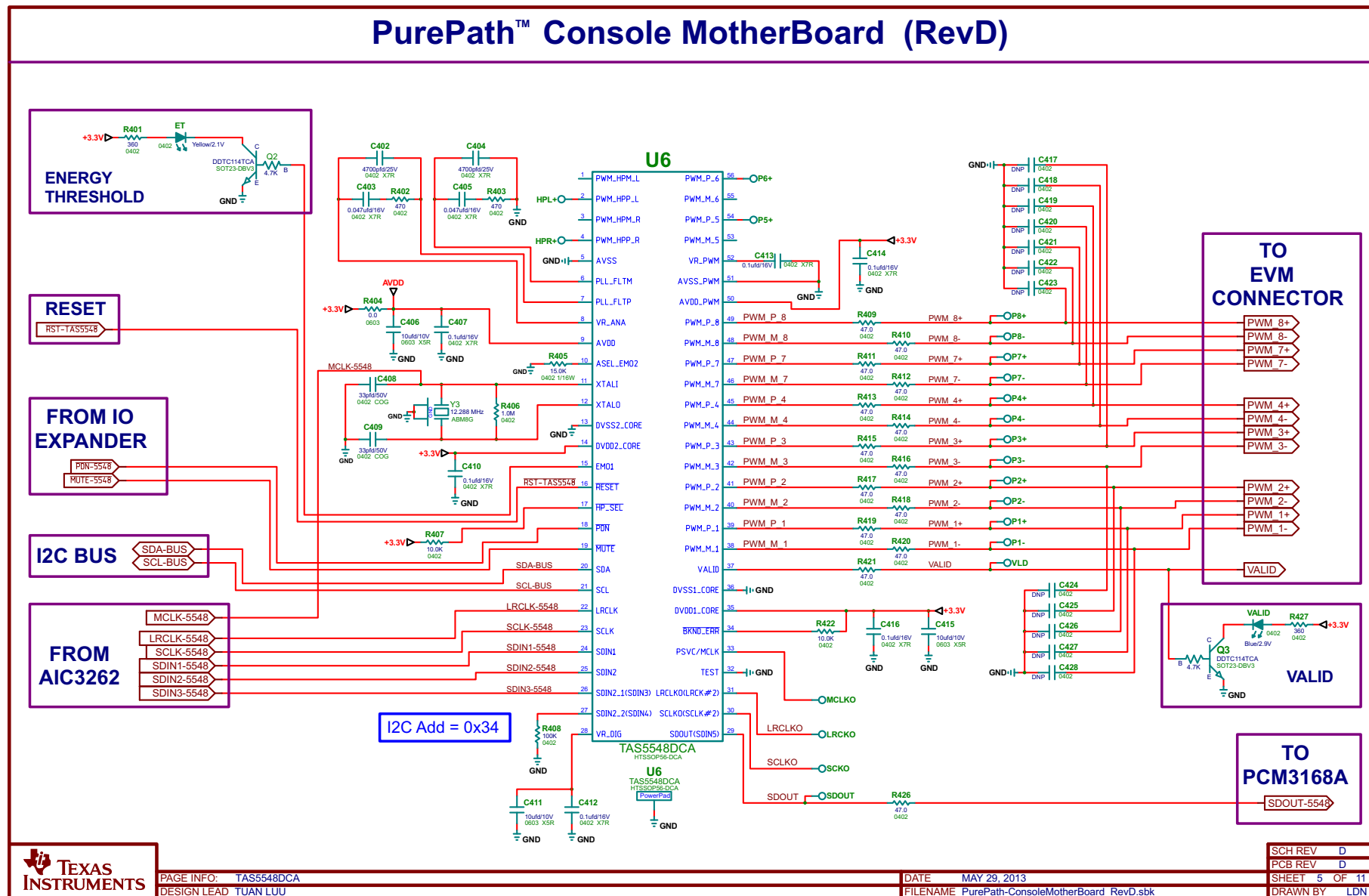

Figure 25. PurePath Console Revisions D and E (5 of 10)

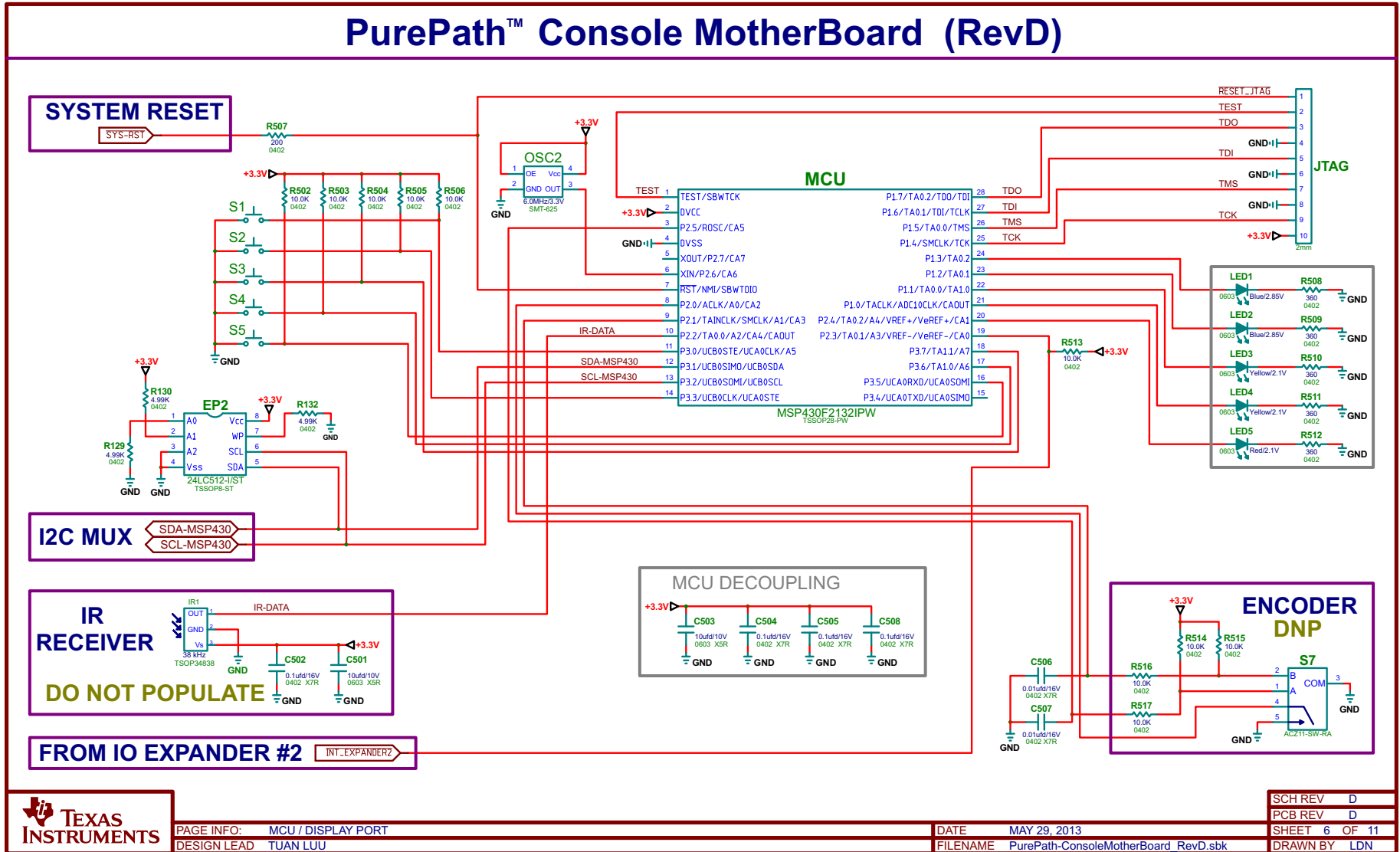

Figure 26. PurePath Console Revisions D and E (6 of 10)

PurePath™ Console MotherBoard (RevD)

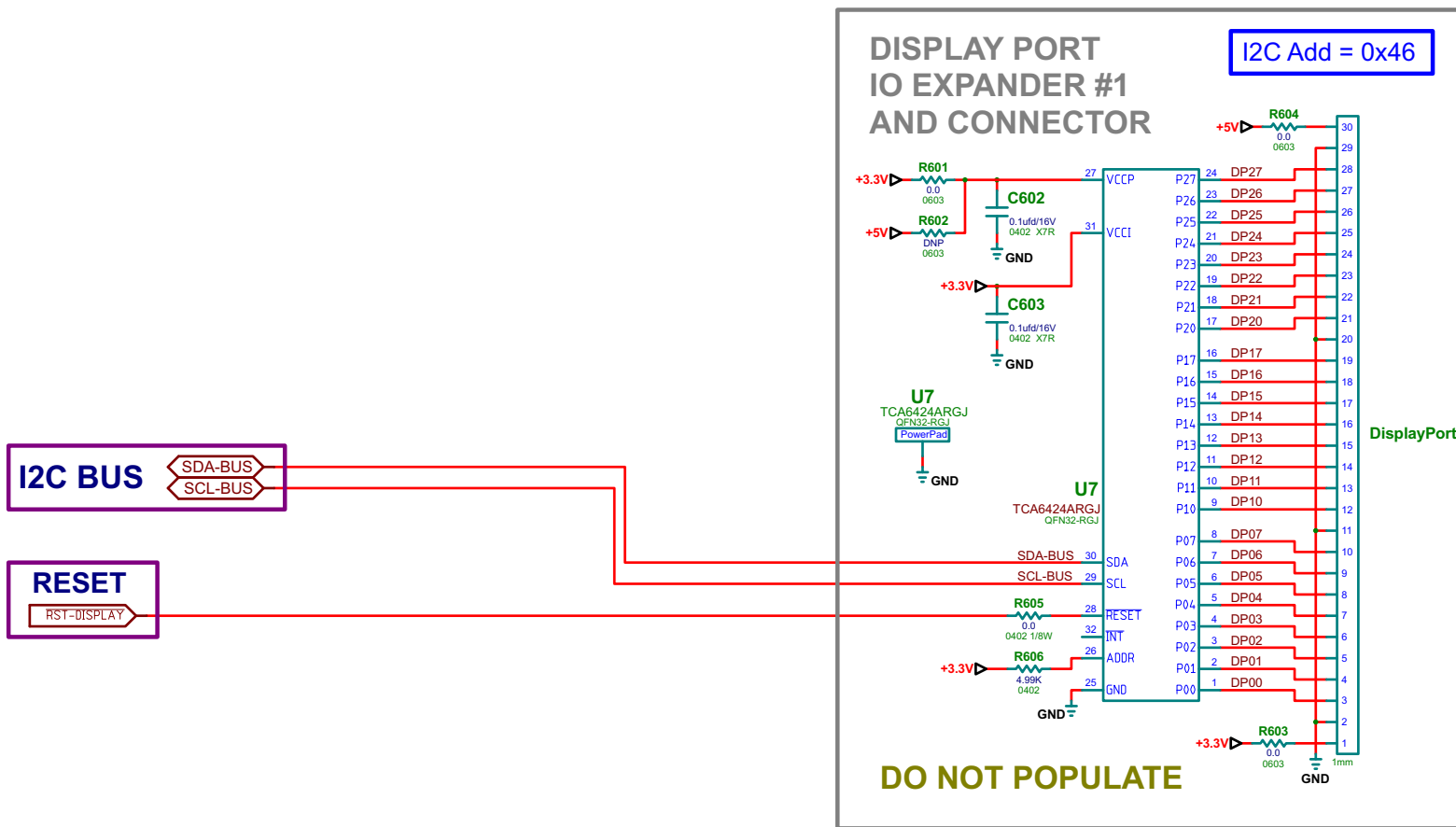

Figure 27. PurePath Console Revisions D and E (7 of 10)

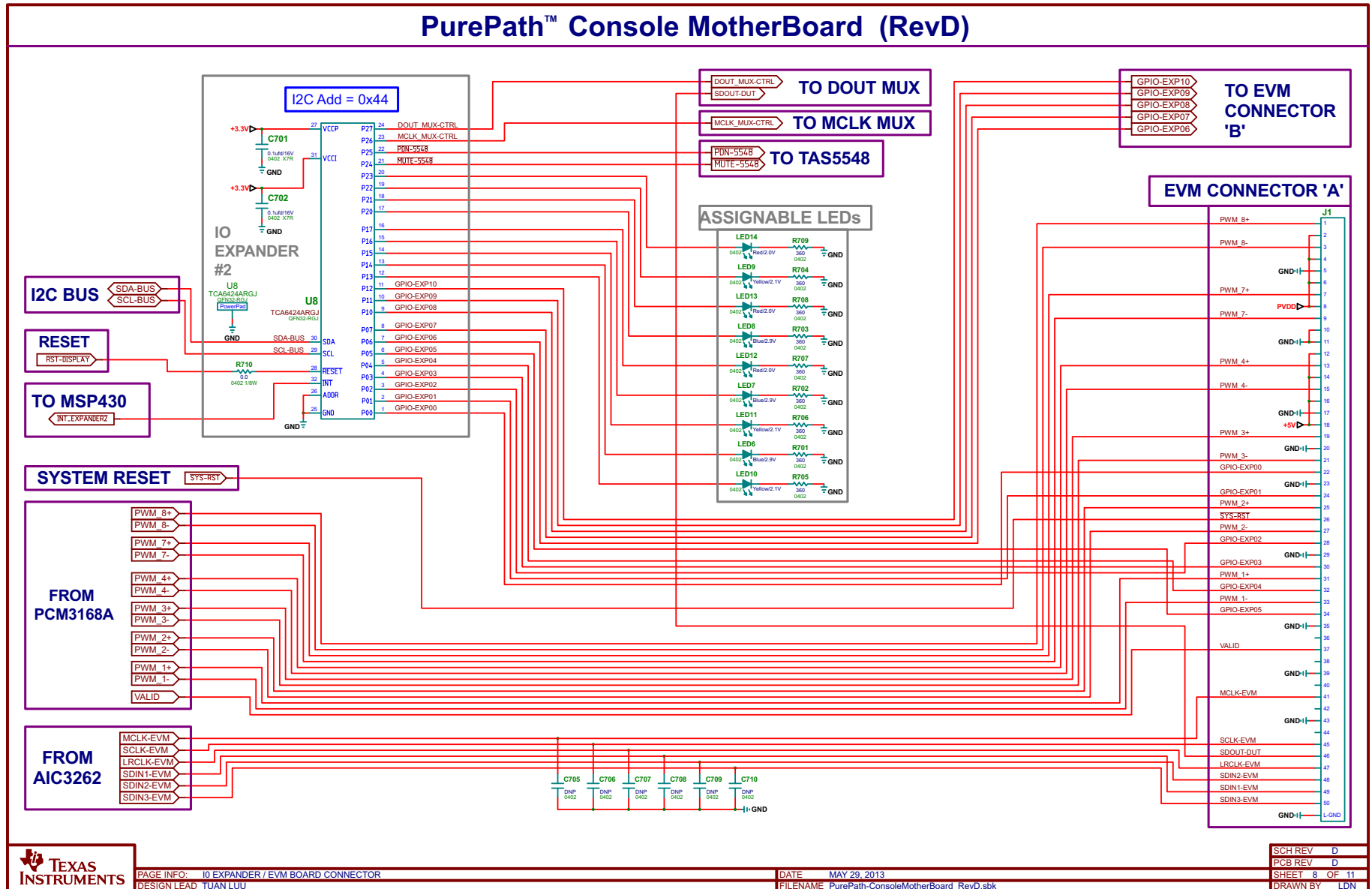
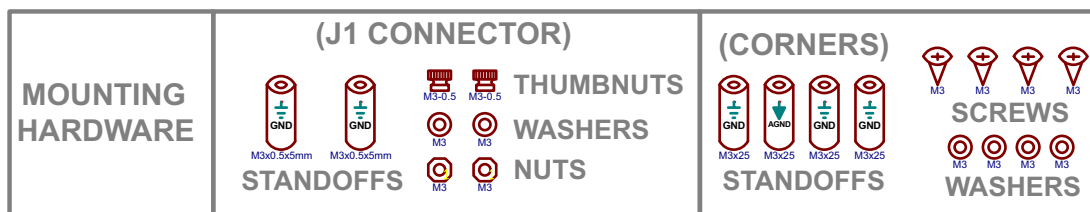
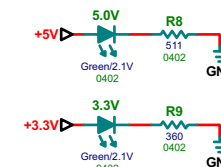
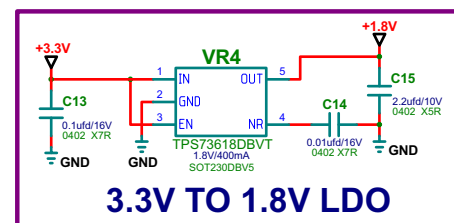
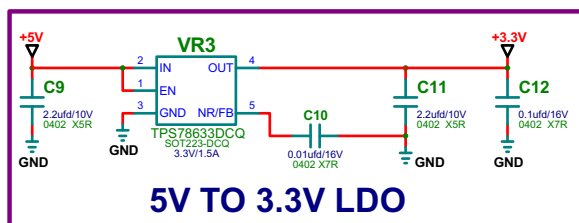
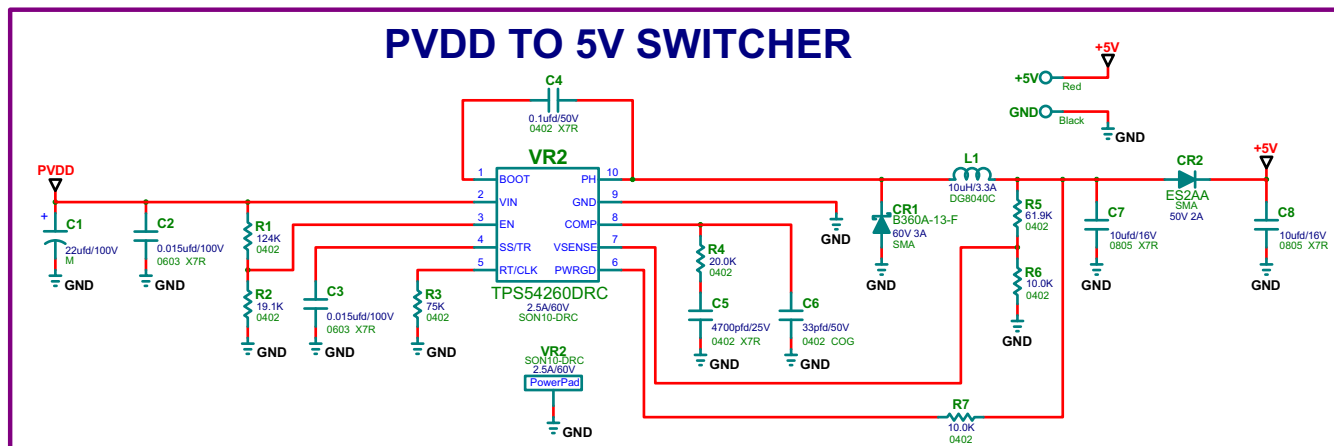

Figure 28. PurePath Console Revisions D and E (8 of 10)

SCH REV	D
PCB REV	D
SHEET	8 OF 11
DRAWN BY	LDN

PurePath™ Console MotherBoard (RevD)



PAGE INFO: POWER SUPPLIES
DESIGN LEAD TUAN LUU

DATE MAY 29, 2013
FILENAME PurePath-ConsoleMotherBoard_RevD.sbk

SCH REV	D
PCB REV	D
SHEET	9 OF 11
DRAWN BY	LDN

Figure 29. PurePath Console Revisions D and E (9 of 10)

PurePath™ Console MotherBoard (RevD)

REVISION HISTORY			
REVISION	DESCRIPTION	DATE	APPROVAL
A	RELEASE	JULY 11, 2012	TL
B	<ol style="list-style-type: none"> 1. CHANGED J1 FROM RIGHT ANGLE TO VERTICLE MOUNT. (QSS-050-01-F-D-A) 2. CHANGED ALL LEDS TO 0402 EXCEPT LEDS 1-5. 3. CHANGE R5 VALUE TO 61.9K OHMS. 4. ADDED 3.3V TO J1-58,60, 62,64. 5. ADDED RESET TO J1-66. 6. DELETED LED6 AND R513. 7. DELETED R245. 8. POPULATED R426, VALUE = 0402-47 OHMS. 9. CONNECTED R426 TO U4-39. 10. ADDED R513 (0402-10K) TO 3.3V AND MCU-19. 11. CONNECTED U8-32 TO MCU-19. 12. ADD CR2 BETWEEN C7 AND C8. 13. ADDED THUMBNUIT PADS FOR J1. 	AUGUST 20, 2012	TL
C	<ol style="list-style-type: none"> 1. DELETED AND SHORTED ACROSS R149 TO R152. 2. DELETED NAND1, R127, R131, R145, R146, R423, R424, R425. 3. RENAMED LED7-LED15 TO LED6-LED14. 4. RENAMED AND6 TO AND2. 5. RENAMED AND7 TO AND3. 6. RENAMED EEPROM1 TO EP1. 7. CHANGED EP1 TO 24LC512. 8. RENAMED EEPROM2 TO EP2. 9. CHANGED EP2 TO 24LC512. 10. CHANGE U7-26 TO 3.3V PULLUP. 11. MOVE C200, C207, C214 AND C221 TO OUTPUT SIDE OF AIN1 AND AIN2. 12. CHANGED EPROM1/2 TO 512K. 13. ADD AND GATE(AND4) TO SYSTEM RESET. 14. NETS = PB-RESET AND USB-RESET. 15. ADDED RESET NET TO U8-28. 16. ADDED TESTPOINT TO MUX4/5/6 A/B CONTROL PINS. 17. ADDED TESTPOINTS TO PWM OUTPUTS,DELETE S6, R501 AND NET TO MCU-15. 18. ADDED TESTPOINTS TO PWM I2S OUTS MCLK, SCLKO, LRCLKO, SDOUT. 19. ADDED 10K PULLDOWN (R278) TO MUX2-IN1/2. 20. ADDED ZERO OHM RESISTOR MUX3-6. 21. ADDED DNP PULLDOWN RESISTOR TO MUX4/5/6 IN/A/B CONTROL. 22. ADDED VALID LED AND DRIVER. 23. ADDED I2C ADDRESSES. 	DECEMBER 11, 2012	TL
D	<ol style="list-style-type: none"> 1. DELETED 1.8V LED, R10, FB10, FB12. 2. CONVERTED PSIA 2 PIN HEADER TO 3 PIN I2S BYPASS HEADERS. 3. CONNECTED I2S-3262 TO PIN 1 OF BYPASS HEADERS. 4. GROUNDED U3-27. 5. CHANGED OPTO-IN PART TO PLR135/T10. 6. CHANGED R133/R134 TO 0402/2.00K OHMS. 7. REPLACED Q3 WITH NPN TRANSISTOR AND REMAPPED LED DRIVER. 8. ON PCB: RECONNECTED ISOLATED 3.3V POWER PLANE ON LAYER 3. 	MAY 29, 2013	TL



PAGE INFO: REVISION HISTORY
DESIGN LEAD TUAN LUU

DATE MAY 29, 2013
FILENAME PurePath-ConsoleMotherBoard_RevD.sbk

SCH REV	D
PCB REV	D
SHEET	10 OF 11
DRAWN BY	LDN

Figure 30. PurePath Console Revisions D and E (10 of 10)

4.5 PurePath Console, Revision F, Schematic

Figure 31 through Figure 42 show the schematics for the PurePath Console, revision F.

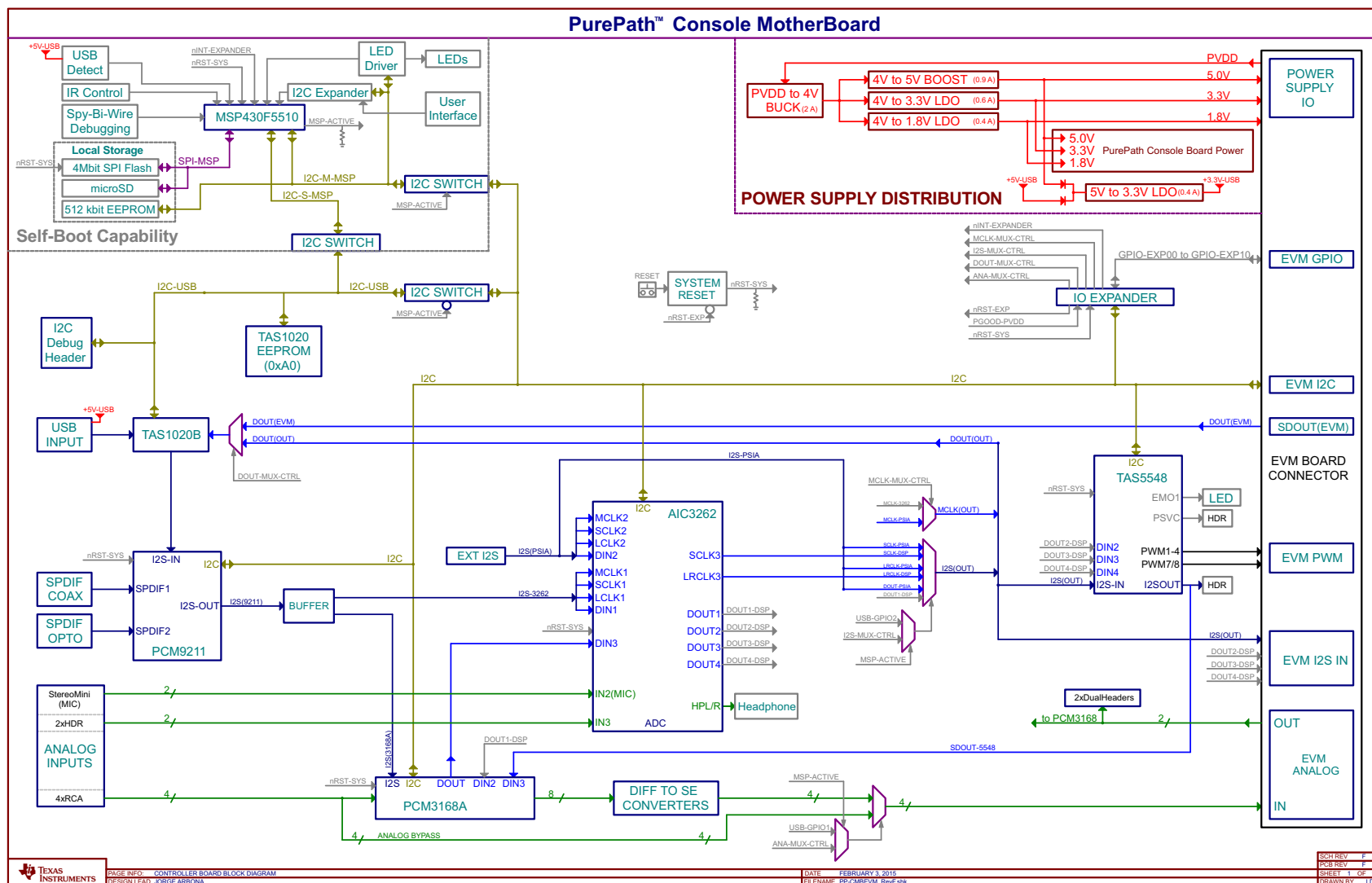

Figure 31. PurePath Console Revision F (1 of 12)

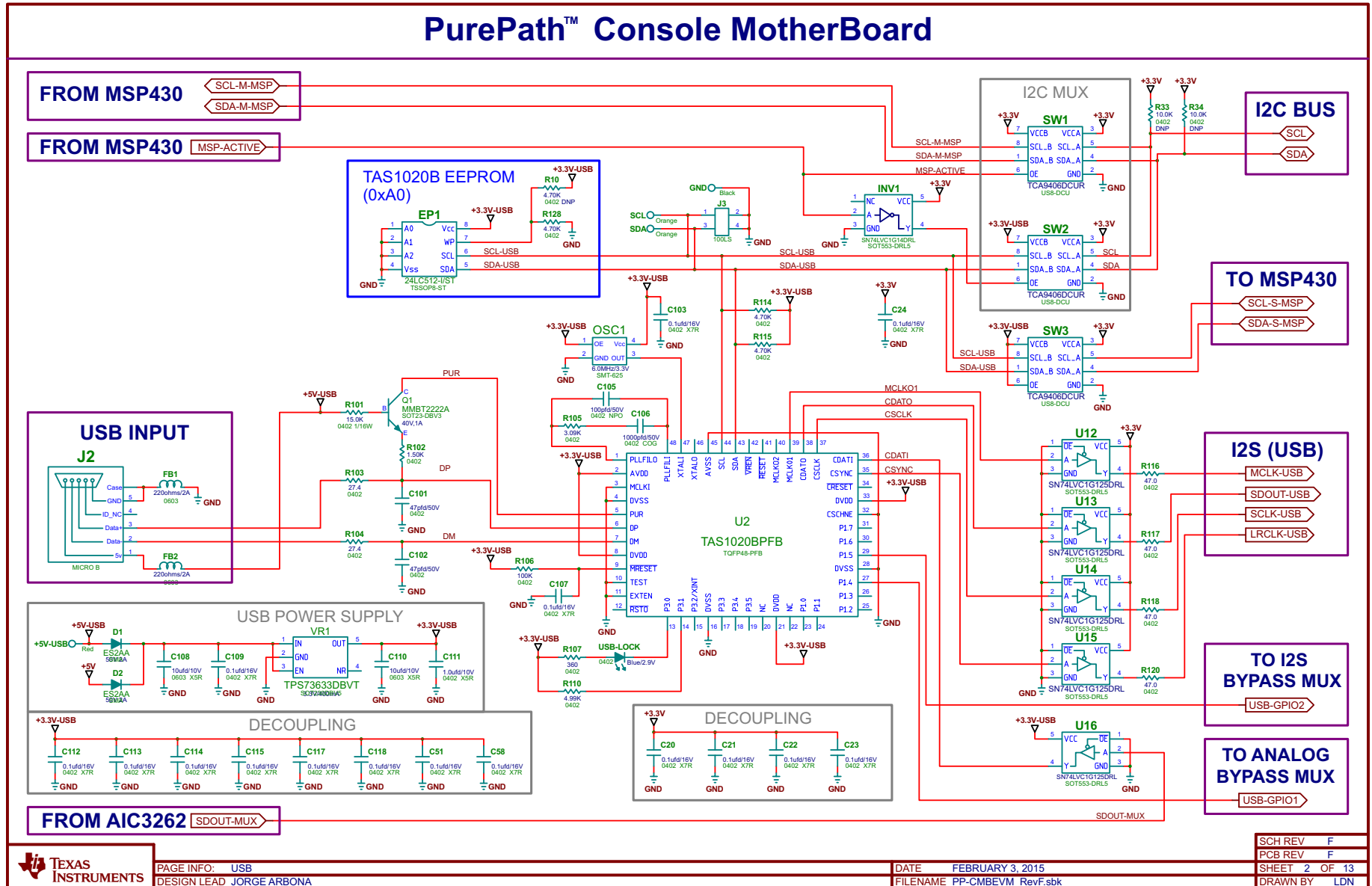

Figure 32. PurePath Console Revision F (2 of 12)

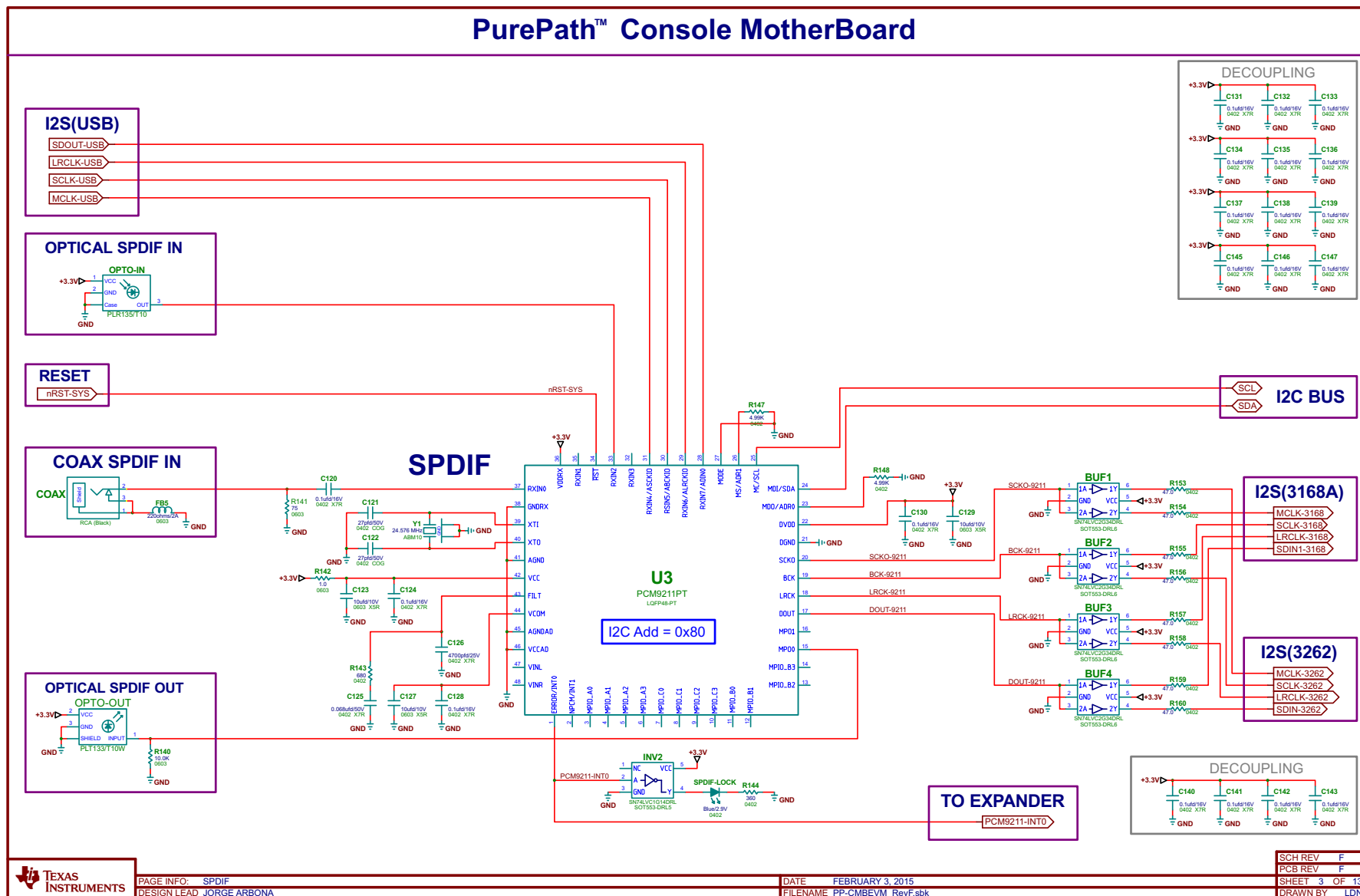

Figure 33. PurePath Console Revision F (3 of 12)

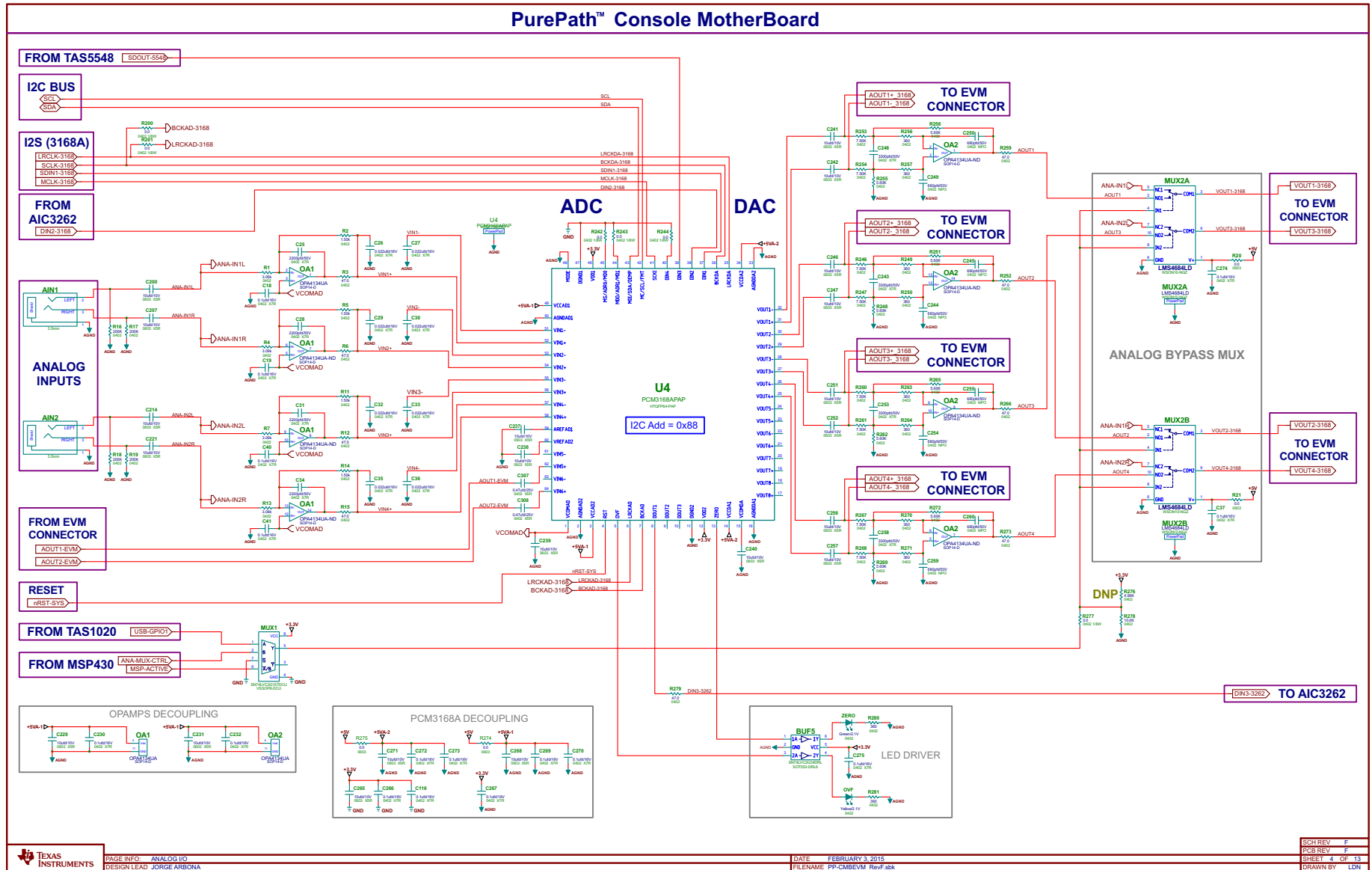

Figure 34. PurePath Console Revision F (4 of 12)

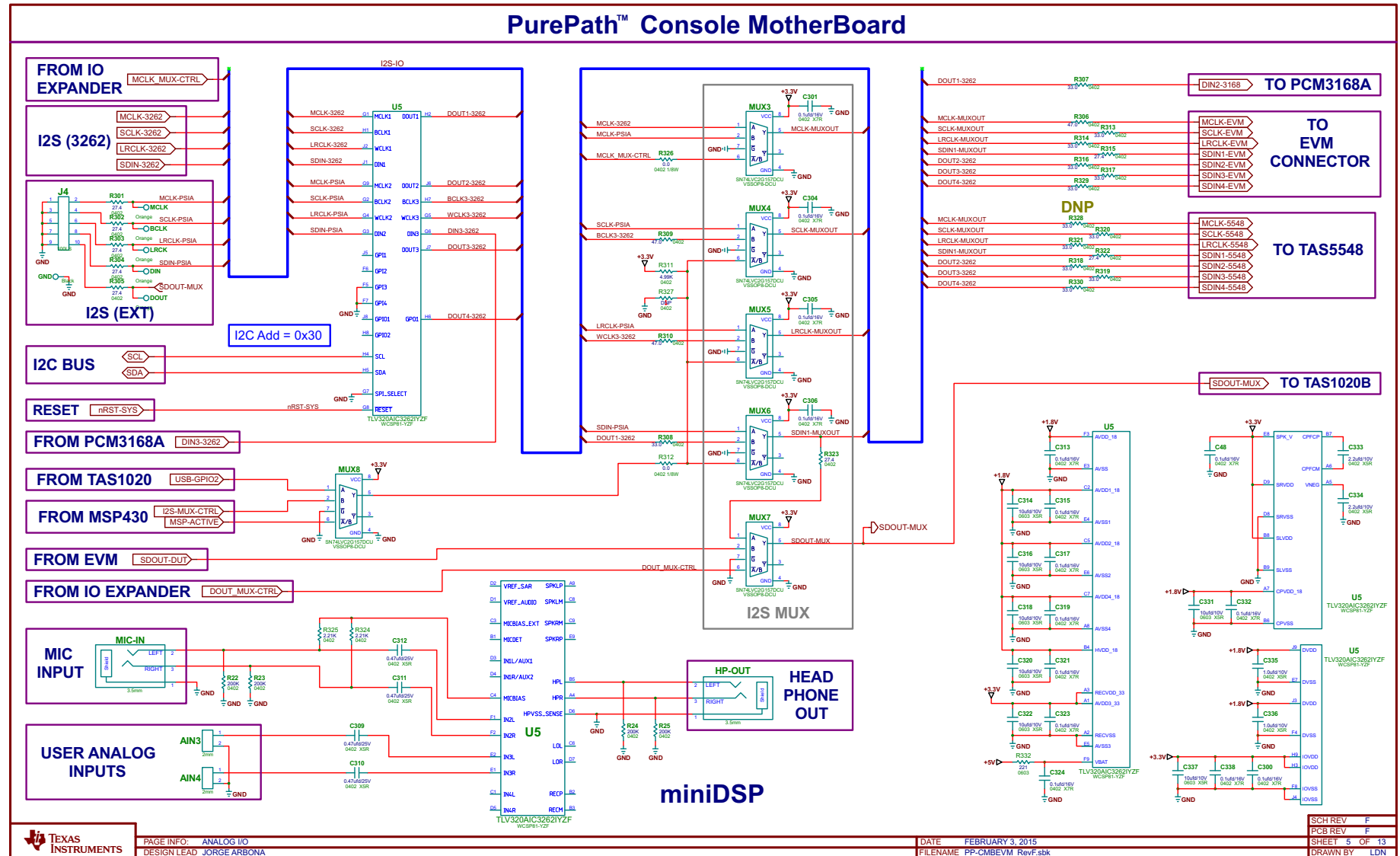

Figure 35. PurePath Console Revision F (5 of 12)

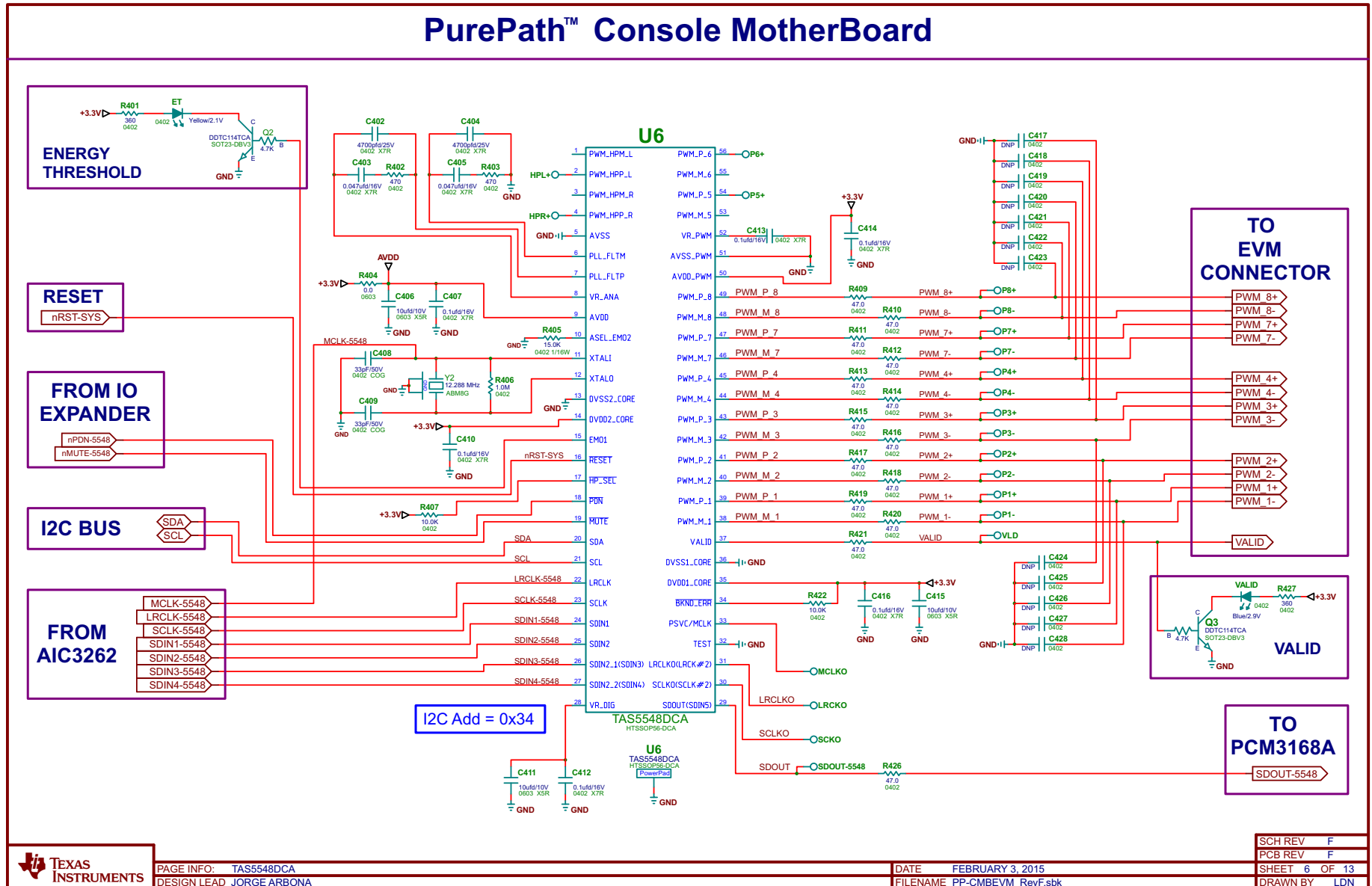

Figure 36. PurePath Console Revision F (6 of 12)

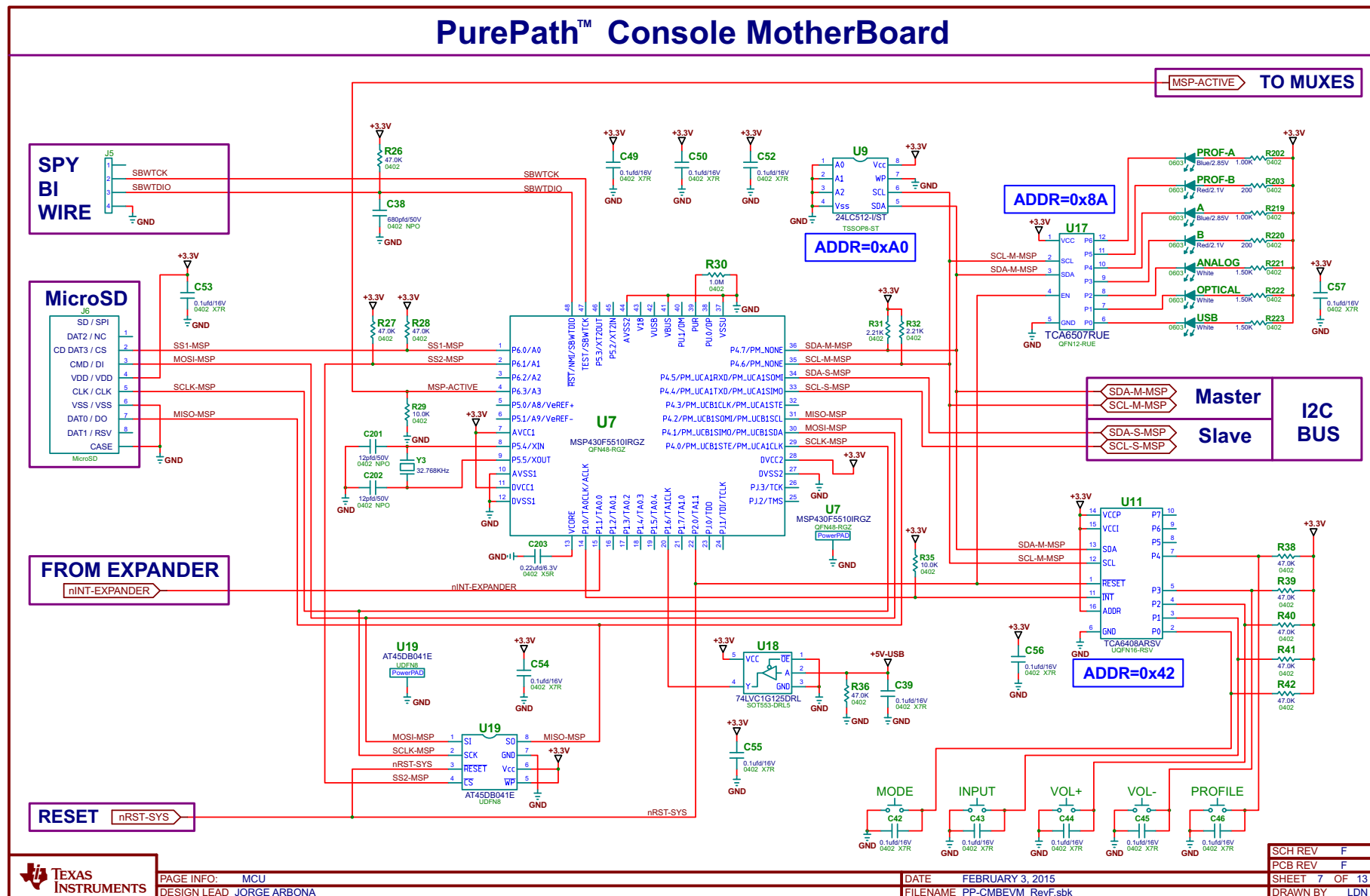

Figure 37. PurePath Console Revision F (7 of 12)

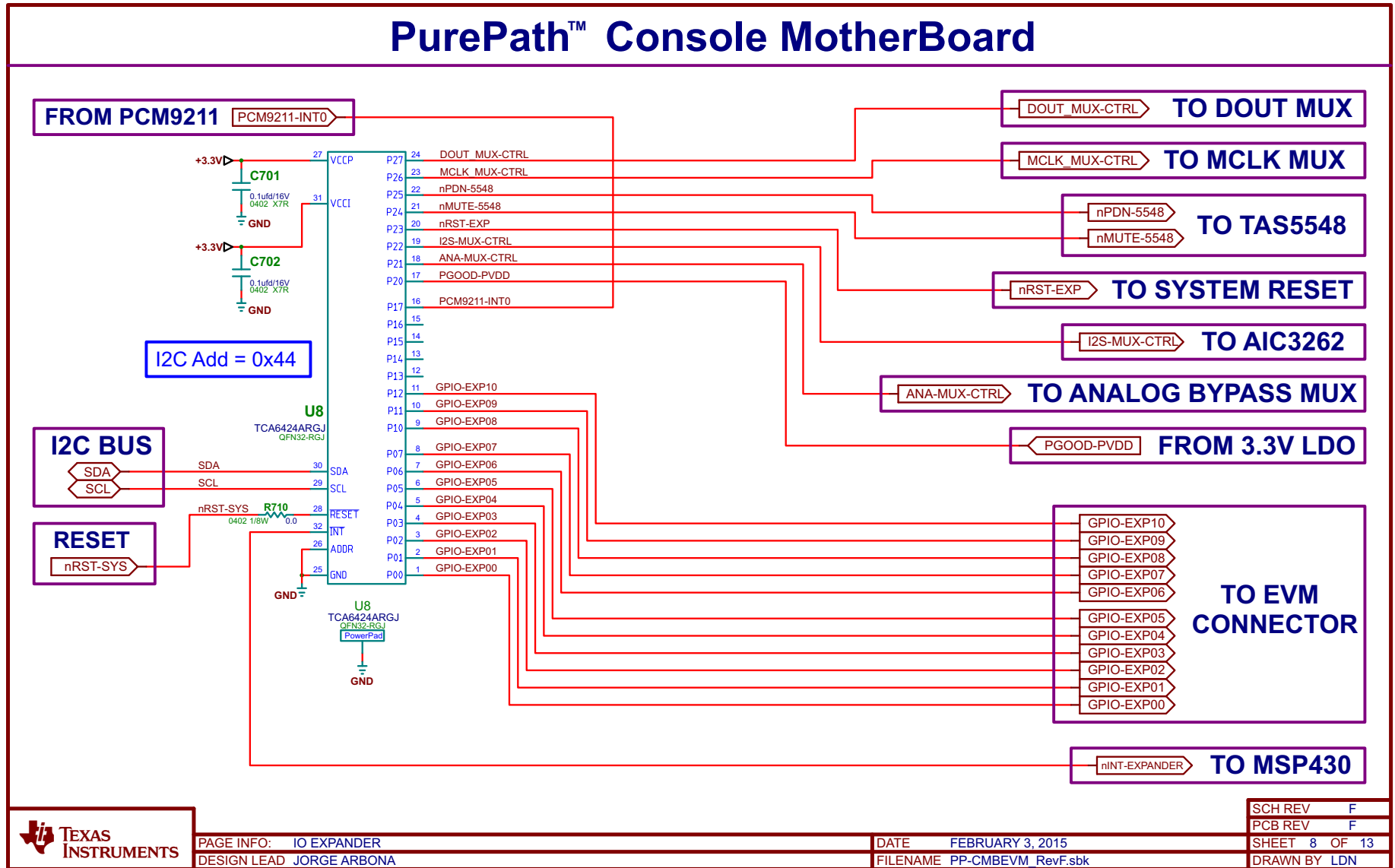

Figure 38. PurePath Console Revision F (8 of 12)

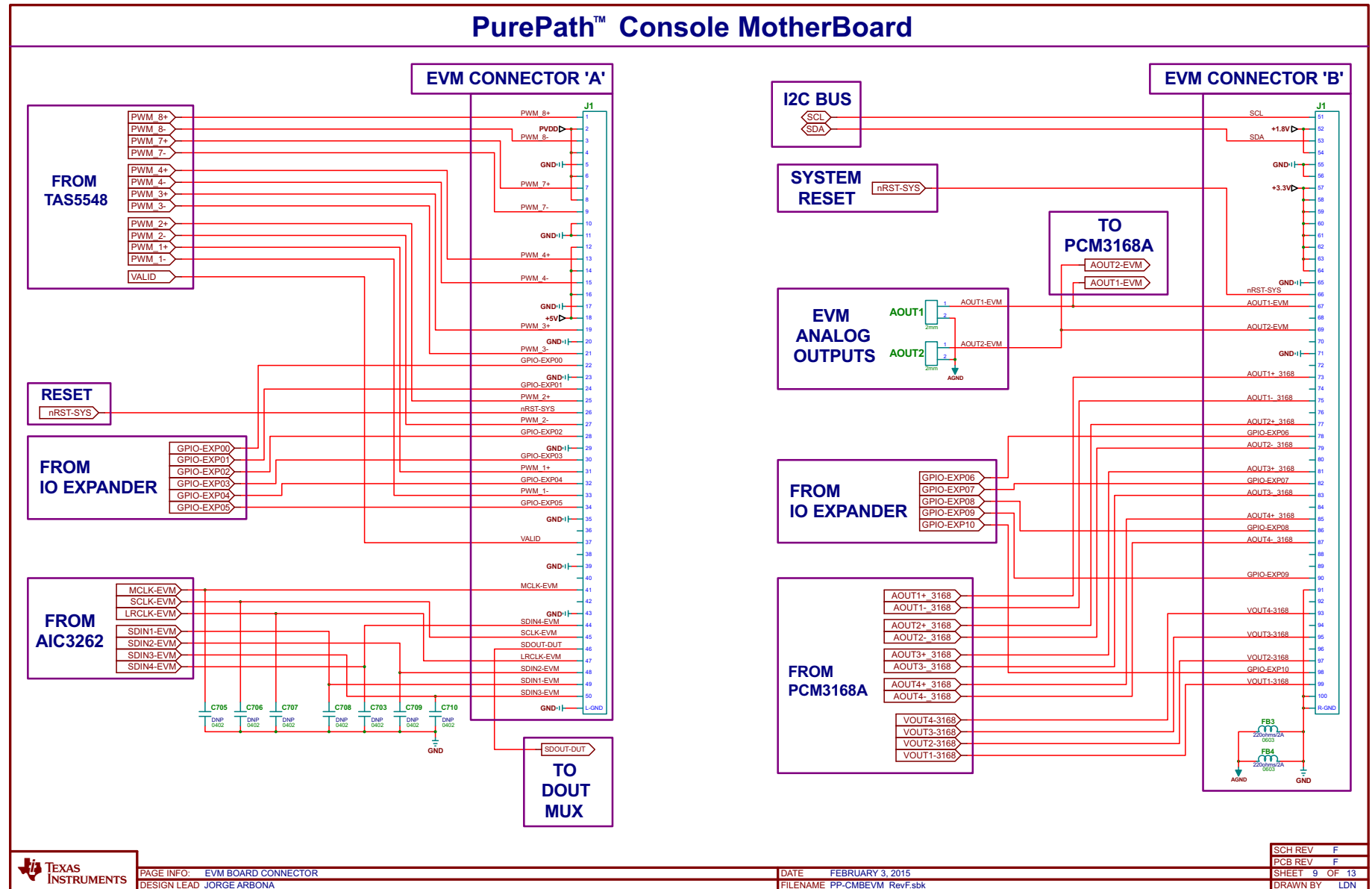

Figure 39. PurePath Console Revision F (9 of 12)

PurePath™ Console MotherBoard

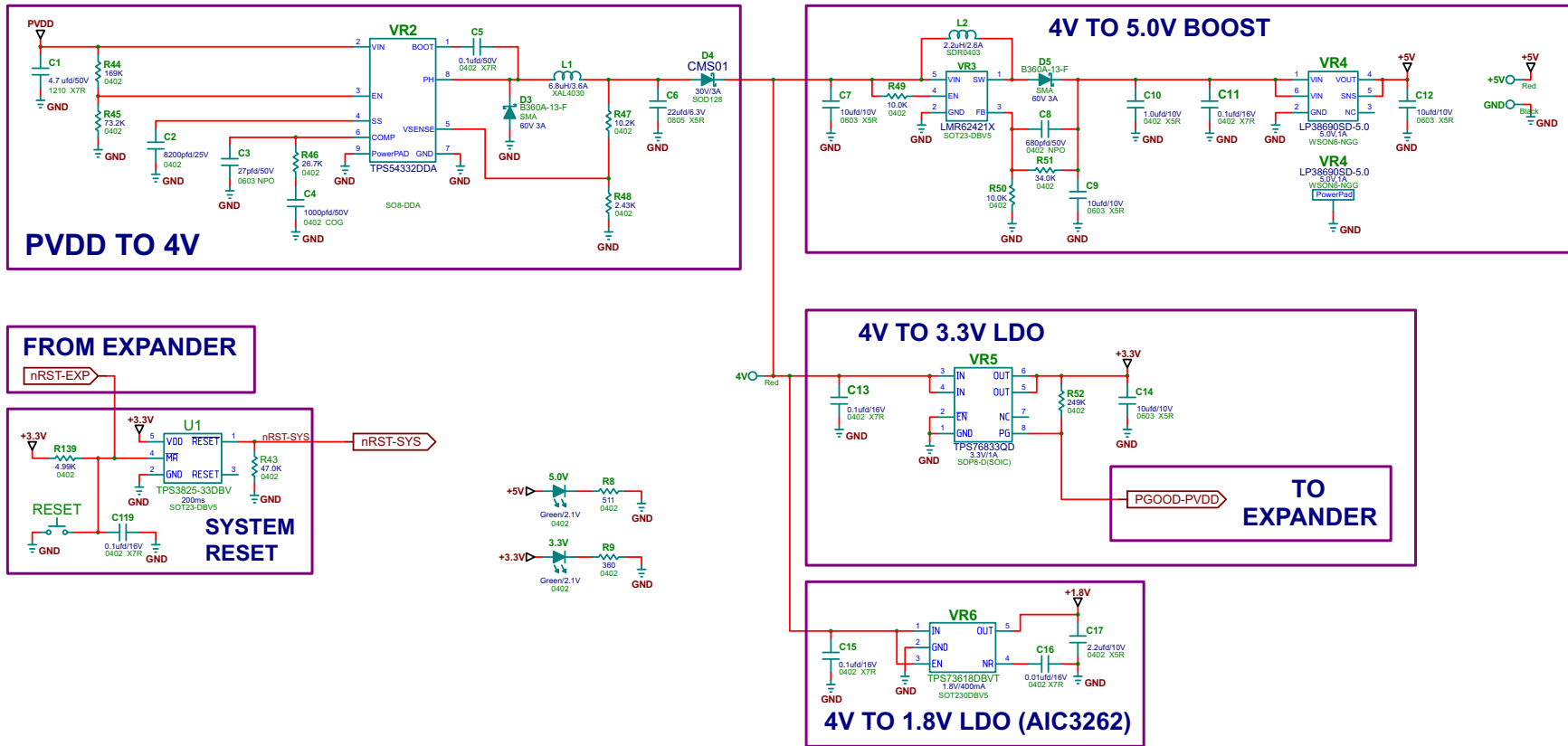

Figure 40. PurePath Console Revision F (10 of 12)

PurePath™ Console MotherBoard

STANDOFF HARDWARE

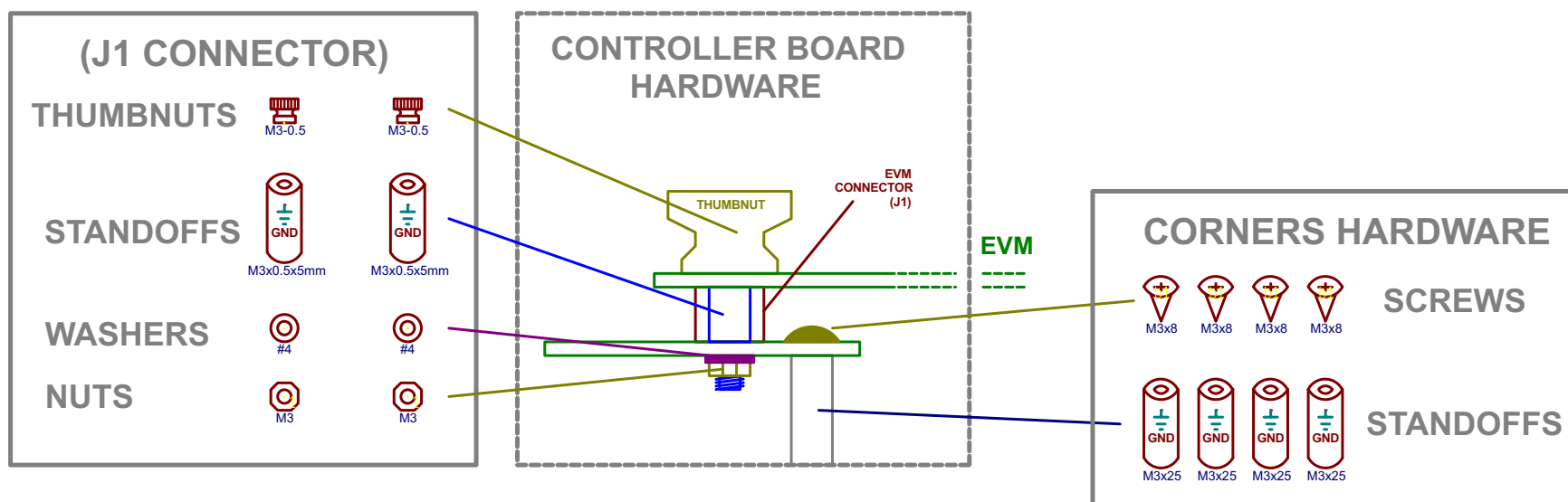

Figure 41. PurePath Console Revision F (11 of 12)

PurePath™ Console MotherBoard

REVISION HISTORY			
REVISION	DESCRIPTION	DATE	APPROVAL
A	RELEASE	JULY 11, 2012	TL
B	<ol style="list-style-type: none"> 1. CHANGED J1 FROM RIGHT ANGLE TO VERTICAL MOUNT. (QSS-050-01-F-D-A) 2. CHANGED ALL LEDS TO 0402 EXCEPT LEDS 1-5. 3. CHANGE R5 VALUE TO 61.9K OHMS. 4. ADDED 3.3V TO J1-58,60, 62,64. 5. ADDED RESET TO J1-66. 6. DELETED LED6 AND R513. 7. DELETED R245. 8. POPULATED R426. VALUE = 0402-47 OHMS. 9. CONNECTED R426 TO U4-39. 10. ADDED R513 (0402-10K) TO 3.3V AND MCU-19. 11. CONNECTED U8-32 TO MCU-19. 12. ADD CR2 BETWEEN C7 AND C8. 13. ADDED THUMBNUIT PADS FOR J1. 	AUGUST 20, 2012	TL
C	<ol style="list-style-type: none"> 1. DELETED AND SHORTED ACROSS R149 TO R152. 2. DELETED NAND1, R127, R131, R145, R146, R423, R424, R425. 3. RENAMED LED7-LED15 TO LED6-LED14. 4. RENAMED AND6 TO AND2. 5. RENAMED AND7 TO AND3. 6. RENAMED EEPROM1 TO EP1. 7. CHANGED EP1 TO 24LCS12. 8. RENAMED EEPROM2 TO EP2. 9. CHANGED EP2 TO 24LCS12. 10. CHANGE U7-26 TO 3.3V PULLUP. 11. MOVE C200, C207, C214 AND C221 TO OUTPUT SIDE OF AN1 AND AN2. 12. CHANGED EPROM1/2 TO 512K. 13. ADD AND GATE(AND4) TO SYSTEM RESET. 14. NETS = PB-RESET AND USB-RESET. 15. ADDED RESET NET TO U8-28. 16. ADDED TESTPOINT TO MUX4/5/6 A/B CONTROL PINS. 17. ADDED TESTPOINTS TO PWM OUTPUTS.DELETE S6, R501 AND NET TO MCU-15. 18. ADDED TESTPOINTS TO PWM I2S OUTS.MCLK, SCLKO, LRCLKO, SDOUT. 19. ADDED 10K PULLDOWN (R278) TO MUX2-IN1/2. 20. ADDED ZERO OHM RESISTOR MUX3-6. 21. ADDED DNP PULLDOWN RESISTOR TO MUX4/5/6 IN/A/B CONTROL. 22. ADDED VALID LED AND DRIVER. 23. ADDED I2C ADDRESSES. 	DECEMBER 11, 2012	TL
D	<ol style="list-style-type: none"> 1. DELETED 1.8V LED, R10, FB10, FB12. 2. CONVERTED PSIA 2 PIN HEADER TO 3 PIN I2S BYPASS HEADERS. 3. CONNECTED I2S-3262 TO PIN 1 OF BYPASS HEADERS. 4. GROUNDED U3-27. 5. CHANGED OPTO-IN PART TO PLS135/T10. 6. CHANGED R133/R134 TO 0402/2.00K OHMS. 7. REPLACED O3 WITH NPN TRANSISTOR AND REMAPPED LED DRIVER. 8. ON PCB: RECONNECTED ISOLATED 3.3V POWER PLANE ON LAYER 3. 	MAY 29, 2013	TL
E	<ol style="list-style-type: none"> 1. CHANGED SW1/SW2/SW3 TO PCA9515BDGKR 	JANUARY 16, 2015	JA
F	<ol style="list-style-type: none"> 1. FIXED ANALOG INPUT NOISE ISSUE. 2. RENUMBERED NUMEROUS REFERENCE DESIGNATORS. 3. ADDED I2S AND I2C HEADERS AND TESTPOINTS. 4. CHANGED I2C MUX CIRCUITRY. 5. MOVED I2C HEADER TO USB VOLTAGE DOMAIN. 6. ADDED SELF BOOTING CAPABILITY. 7. REROUTED MOST OF PCB TO ALLOW FOR NEW CIRCUITS. 8. CHANGED CLOCKING SCHEME. 9. UPDATED POWERPAD FOOTPRINTS. 10. FIXED I2S SWITCH ISSUES. 11. PP-CMB OPERATING VOLTAGE RANGE IS NOW 4.5V TO 26VDC. 12. REDESIGNED POWER SUPPLY CIRCUITS. 	FEBRUARY 3, 2015	JA

	PAGE INFO: REVISION HISTORY	DATE: FEBRUARY 3, 2015	BOARD NAME: AIP006	SCH REV: F
	DESIGN LEAD: JORGE ARBONA	FILENAME: PP-CMBEVM_RevF.sbk		PCB REV: F
				SHEET 12 OF 13
				DRAWN BY: LDN

Figure 42. PurePath Console Revision F (12 of 12)

TEXAS INSTRUMENTS DISCLAIMER

The information and materials ("Materials") provided here are provided by Texas Instruments Incorporated ("TI") as a service to its customers and/or suppliers, and may be used for informational purposes only, and only subject to the following terms. By downloading or viewing these Materials, you are signifying your assent to these terms.

- 1.) These preliminary evaluation schematics are intended for use for **PRELIMINARY ENGINEERING DEVELOPMENT AND EVALUATION PURPOSES ONLY** and are not considered by Texas Instruments to be fit as a basis for establishing production products or systems. This information may be incomplete in several respects, including but not limited to information relating to required design, marketing, and/or manufacturing-related protective considerations and product safety measures typically found in the end-product incorporating the goods.
- 2.) Accordingly, neither TI nor its suppliers warrant the accuracy or completeness of the information, text, graphics, links or other items contained within the Materials. TI may make changes to the Materials, or to the products described therein, at any time without notice. TI makes no commitment to update the Materials.
- 3.) TI assumes no liability for applications assistance, customer product design, software performance, or services that may be described or referenced in the Materials. The user assumes all responsibility and liability for proper and safe design and handling of goods. Accordingly, the user indemnifies TI from all claims arising from its use of the Materials.
- 4.) TI currently deals with various customers for products, and therefore our arrangement with the user will not be exclusive. TI makes no representations regarding the commercial availability of non-TI components that may be referenced in the Materials.
- 5.) No license is granted under any patent right or other intellectual property right of TI covering or relating to any combination, machine, or process in which such TI products or services might be or are used. Except as expressly provided herein, TI and its suppliers do not grant any express or implied right to you under any patents, copyrights, trademarks, or trade secret information.
- 6.) Performance tests and ratings, to the extent referenced in the Materials, are measured using specific computer systems and/or components and reflect the approximate performance of TI products as measured by those tests. Any difference in system hardware or software design or configuration may affect actual performance. Buyers should consult other sources of information to evaluate the performance of systems or components they are considering purchasing.
- 7.) Resale of TI's products or services with statements different from or beyond the parameters stated by TI for that product or service in official TI data books or data sheets voids all express and any implied warranties for the associated TI product or service, and is an unfair and deceptive business practice, and TI is not responsible for any such use.
- 8.) The Materials are copyrighted and any unauthorized use may violate copyright, trademark, and other laws. You may only download one copy for your internal use only, unless you are specifically licensed to do otherwise by TI in writing. This is a license, not a transfer of title, and is subject to the following restrictions: You may not:
 - (a) modify the Materials (including any associated warranties, conditions, limitations or notices) or use them for any commercial purpose, or any public display, performance, sale or rental;
 - (b) decompile, reverse engineer, or disassemble software Materials except and only to the extent permitted by applicable law;
 - (c) remove any copyright or other proprietary notices from the Materials;
 - (d) transfer the Materials to another person. You agree to prevent any unauthorized copying of the Materials. TI may terminate this license at any time if you are in breach of the terms of this Agreement. Upon termination, you will immediately destroy the Materials.
- 9.) **THE MATERIALS ARE PROVIDED "AS IS" WITHOUT ANY EXPRESS OR IMPLIED WARRANTY OF ANY KIND INCLUDING WARRANTIES OF MERCHANTABILITY, NONINFRINGEMENT OF INTELLECTUAL PROPERTY, OR FITNESS FOR ANY PARTICULAR PURPOSE. IN NO EVENT SHALL TI OR ITS SUPPLIERS BE LIABLE FOR ANY DAMAGES WHATSOEVER (INCLUDING, WITHOUT LIMITATION, DAMAGES FOR LOSS OF PROFITS, BUSINESS INTERRUPTION, LOSS OF INFORMATION) ARISING OUT OF THE USE OF OR INABILITY TO USE THE MATERIALS, EVEN IF TI HAS BEEN ADVISED OF THE POSSIBILITY OF SUCH DAMAGES.**



Figure 43. PurePath Console Revisions D, E, and F

IMPORTANT NOTICE

Texas Instruments Incorporated and its subsidiaries (TI) reserve the right to make corrections, enhancements, improvements and other changes to its semiconductor products and services per JESD46, latest issue, and to discontinue any product or service per JESD48, latest issue. Buyers should obtain the latest relevant information before placing orders and should verify that such information is current and complete. All semiconductor products (also referred to herein as "components") are sold subject to TI's terms and conditions of sale supplied at the time of order acknowledgment.

TI warrants performance of its components to the specifications applicable at the time of sale, in accordance with the warranty in TI's terms and conditions of sale of semiconductor products. Testing and other quality control techniques are used to the extent TI deems necessary to support this warranty. Except where mandated by applicable law, testing of all parameters of each component is not necessarily performed.

TI assumes no liability for applications assistance or the design of Buyers' products. Buyers are responsible for their products and applications using TI components. To minimize the risks associated with Buyers' products and applications, Buyers should provide adequate design and operating safeguards.

TI does not warrant or represent that any license, either express or implied, is granted under any patent right, copyright, mask work right, or other intellectual property right relating to any combination, machine, or process in which TI components or services are used. Information published by TI regarding third-party products or services does not constitute a license to use such products or services or a warranty or endorsement thereof. Use of such information may require a license from a third party under the patents or other intellectual property of the third party, or a license from TI under the patents or other intellectual property of TI.

Reproduction of significant portions of TI information in TI data books or data sheets is permissible only if reproduction is without alteration and is accompanied by all associated warranties, conditions, limitations, and notices. TI is not responsible or liable for such altered documentation. Information of third parties may be subject to additional restrictions.

Resale of TI components or services with statements different from or beyond the parameters stated by TI for that component or service voids all express and any implied warranties for the associated TI component or service and is an unfair and deceptive business practice. TI is not responsible or liable for any such statements.

Buyer acknowledges and agrees that it is solely responsible for compliance with all legal, regulatory and safety-related requirements concerning its products, and any use of TI components in its applications, notwithstanding any applications-related information or support that may be provided by TI. Buyer represents and agrees that it has all the necessary expertise to create and implement safeguards which anticipate dangerous consequences of failures, monitor failures and their consequences, lessen the likelihood of failures that might cause harm and take appropriate remedial actions. Buyer will fully indemnify TI and its representatives against any damages arising out of the use of any TI components in safety-critical applications.

In some cases, TI components may be promoted specifically to facilitate safety-related applications. With such components, TI's goal is to help enable customers to design and create their own end-product solutions that meet applicable functional safety standards and requirements. Nonetheless, such components are subject to these terms.

No TI components are authorized for use in FDA Class III (or similar life-critical medical equipment) unless authorized officers of the parties have executed a special agreement specifically governing such use.

Only those TI components which TI has specifically designated as military grade or "enhanced plastic" are designed and intended for use in military/aerospace applications or environments. Buyer acknowledges and agrees that any military or aerospace use of TI components which have **not** been so designated is solely at the Buyer's risk, and that Buyer is solely responsible for compliance with all legal and regulatory requirements in connection with such use.

TI has specifically designated certain components as meeting ISO/TS16949 requirements, mainly for automotive use. In any case of use of non-designated products, TI will not be responsible for any failure to meet ISO/TS16949.

Products

Audio	www.ti.com/audio
Amplifiers	amplifier.ti.com
Data Converters	dataconverter.ti.com
DLP® Products	www.dlp.com
DSP	dsp.ti.com
Clocks and Timers	www.ti.com/clocks
Interface	interface.ti.com
Logic	logic.ti.com
Power Mgmt	power.ti.com
Microcontrollers	microcontroller.ti.com
RFID	www.ti-rfid.com
OMAP Applications Processors	www.ti.com/omap
Wireless Connectivity	www.ti.com/wirelessconnectivity

Applications

Automotive and Transportation	www.ti.com/automotive
Communications and Telecom	www.ti.com/communications
Computers and Peripherals	www.ti.com/computers
Consumer Electronics	www.ti.com/consumer-apps
Energy and Lighting	www.ti.com/energy
Industrial	www.ti.com/industrial
Medical	www.ti.com/medical
Security	www.ti.com/security
Space, Avionics and Defense	www.ti.com/space-avionics-defense
Video and Imaging	www.ti.com/video

TI E2E Community

e2e.ti.com