

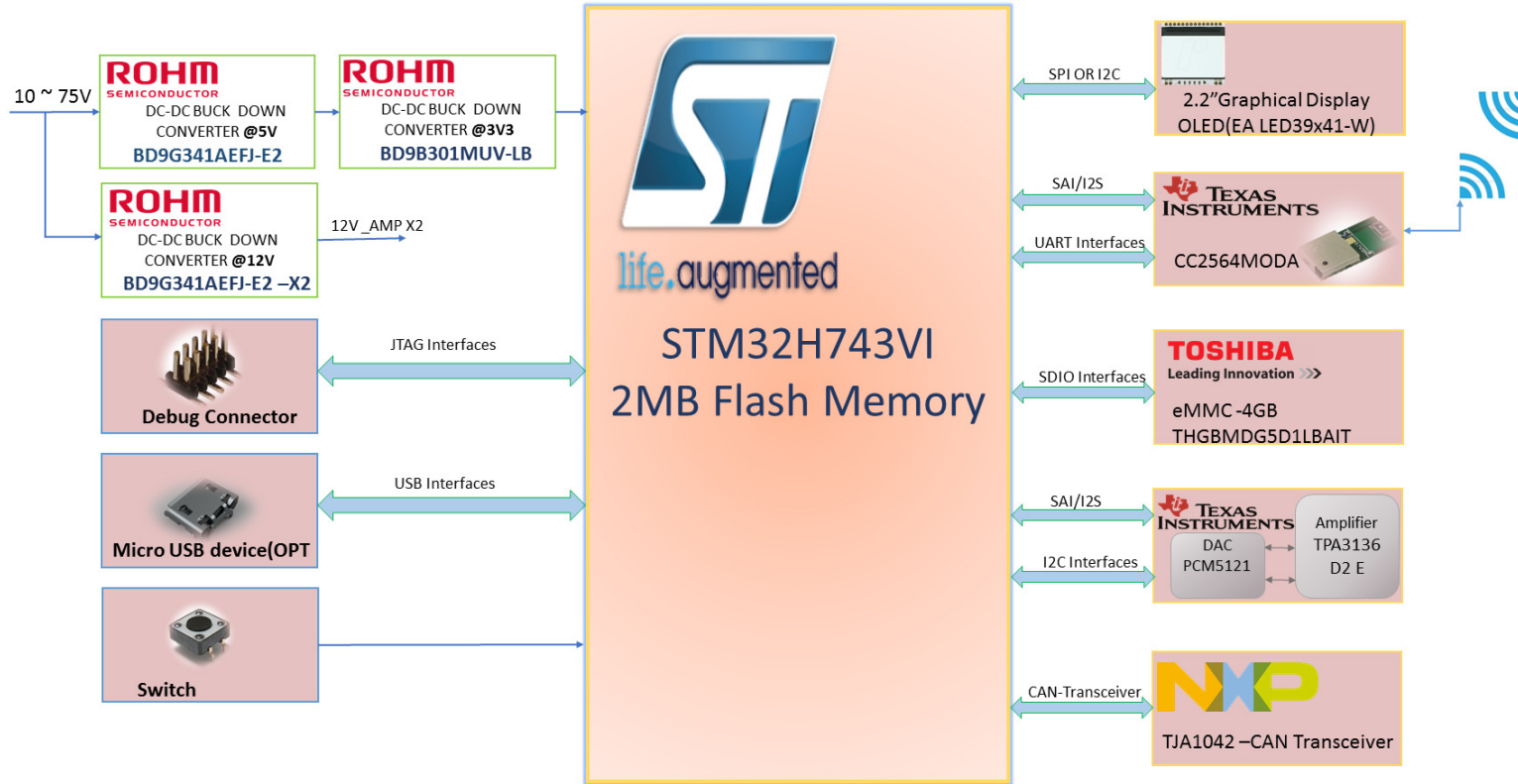

# SYSTEM BLOCK DIAGRAM

## Smart Scooter



 Monday, March 19, 2018			
Size A2	CAGE Code -<Cage Code>	DWG NO SMART SCOOTER	Rev 0.01
Scale		Sheet 2	of 5

**LDO @1V8**

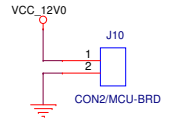
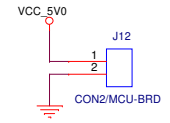
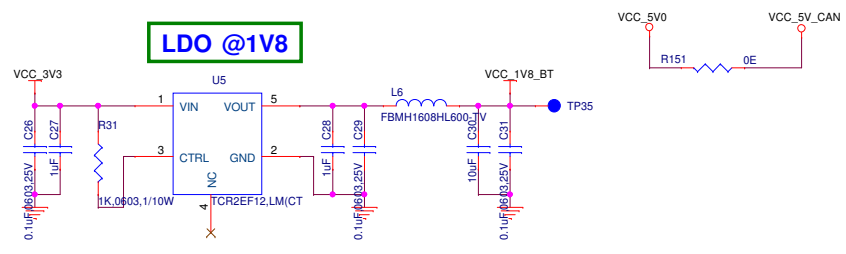

**LDO @3V3**

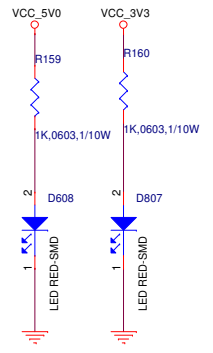
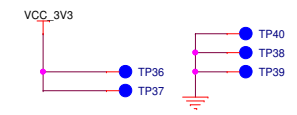
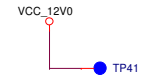
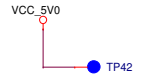
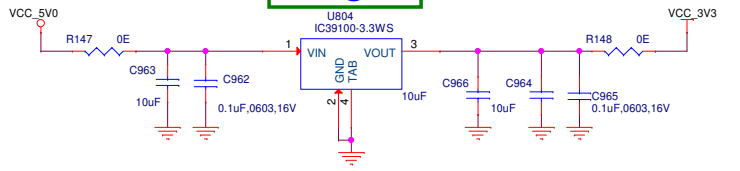

Size	CAGE Code	DWG NO	Rev
A3	<Cage Code>	SMART SCOOTER	0.01
Scale	Sheet		3 of 5



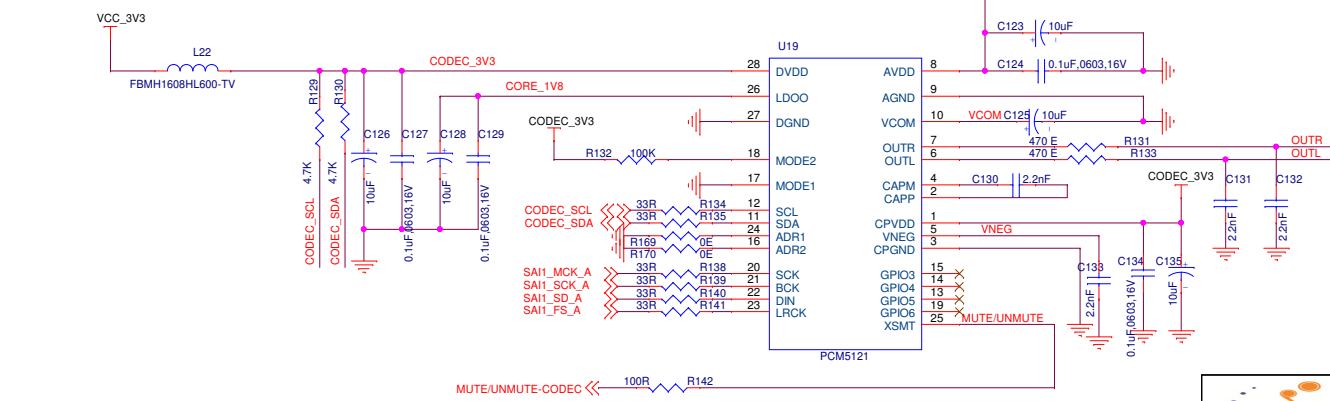
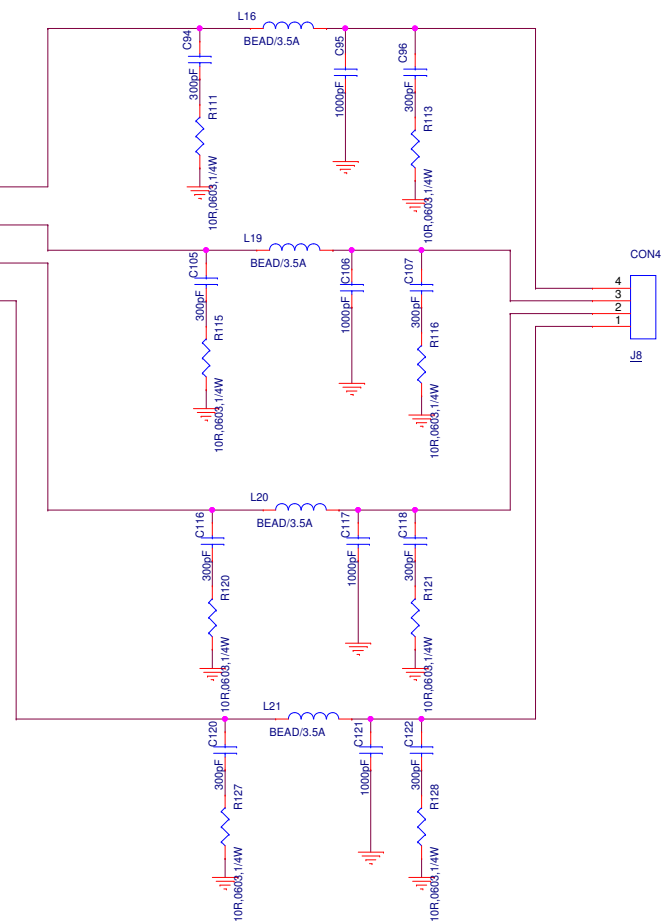
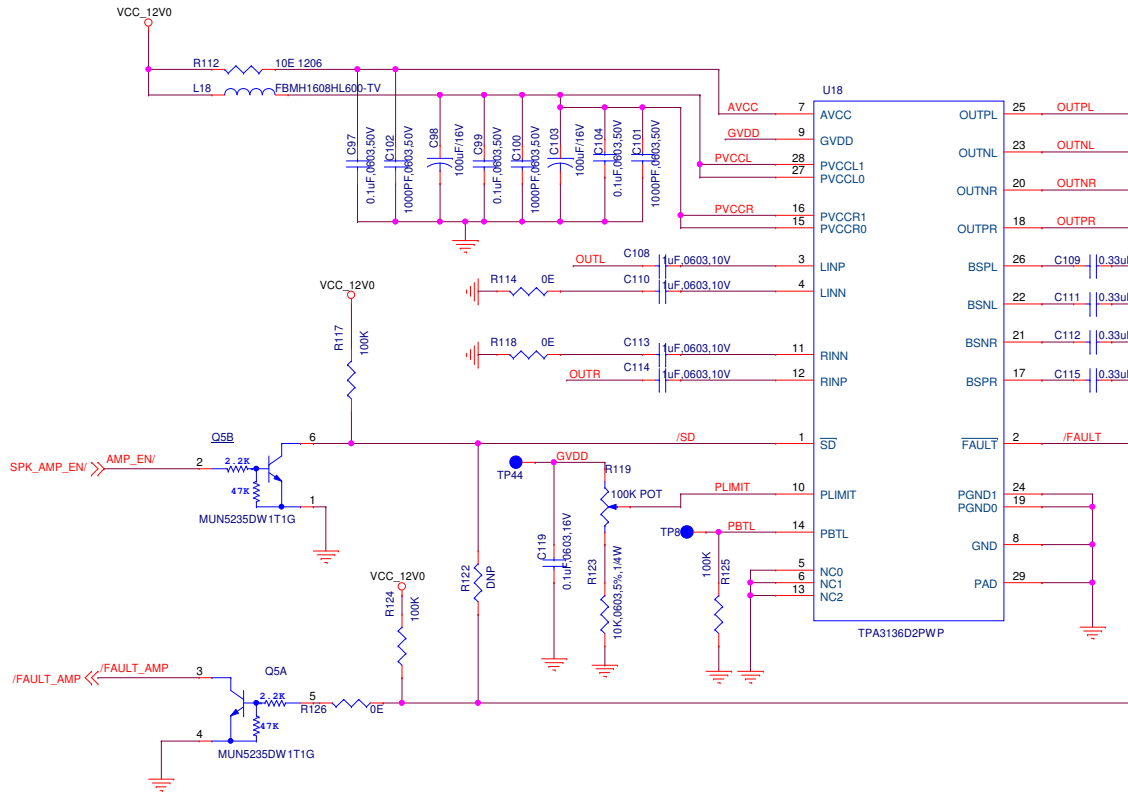

Monday, March 19, 2018

Size	A3	CAGE Code	<Cage Code>	DWG NO	SMART SCOOTER	Rev	0.01
Scale					Sheet	5	of 5