

# The General SAR Driving Circuit

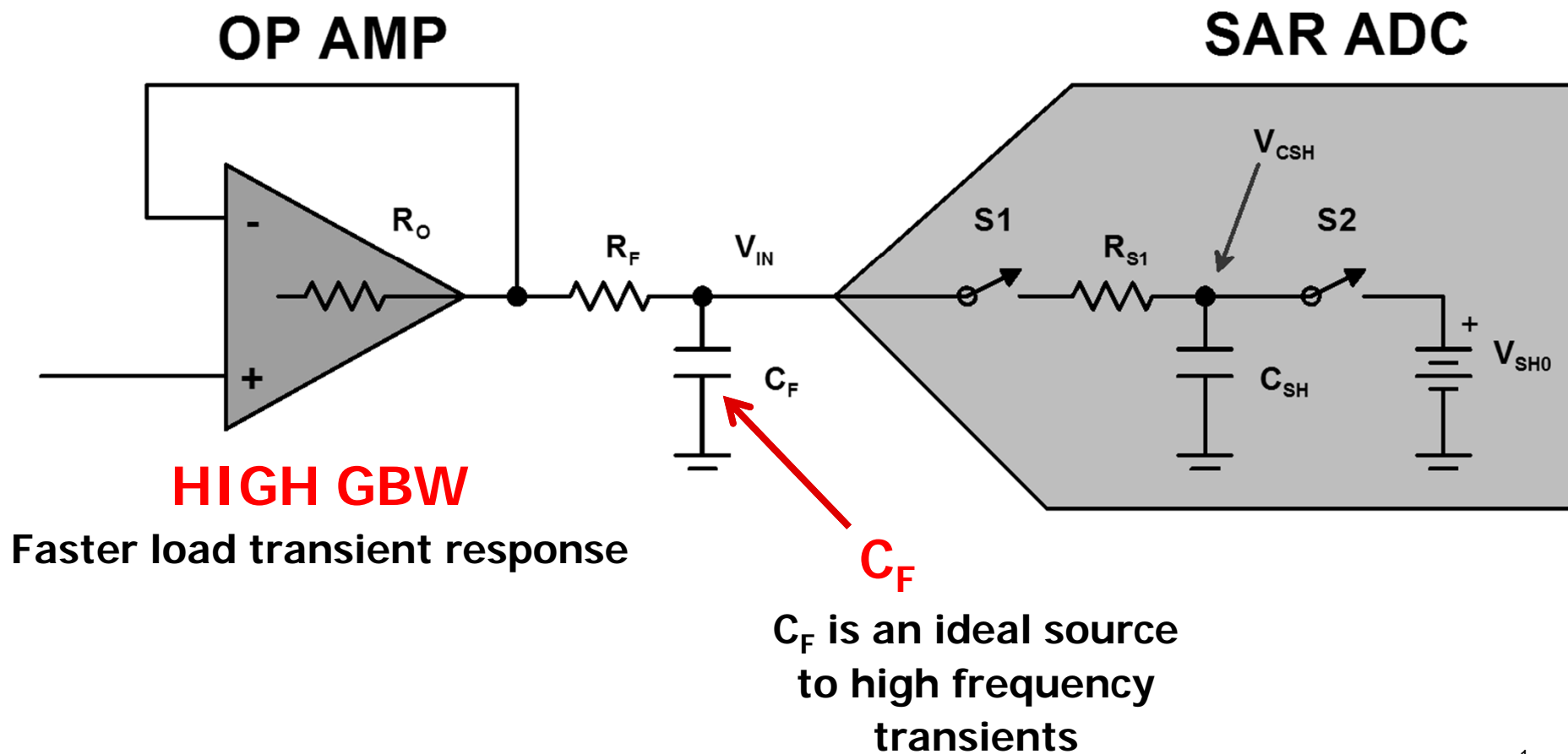

# Charge Bucket

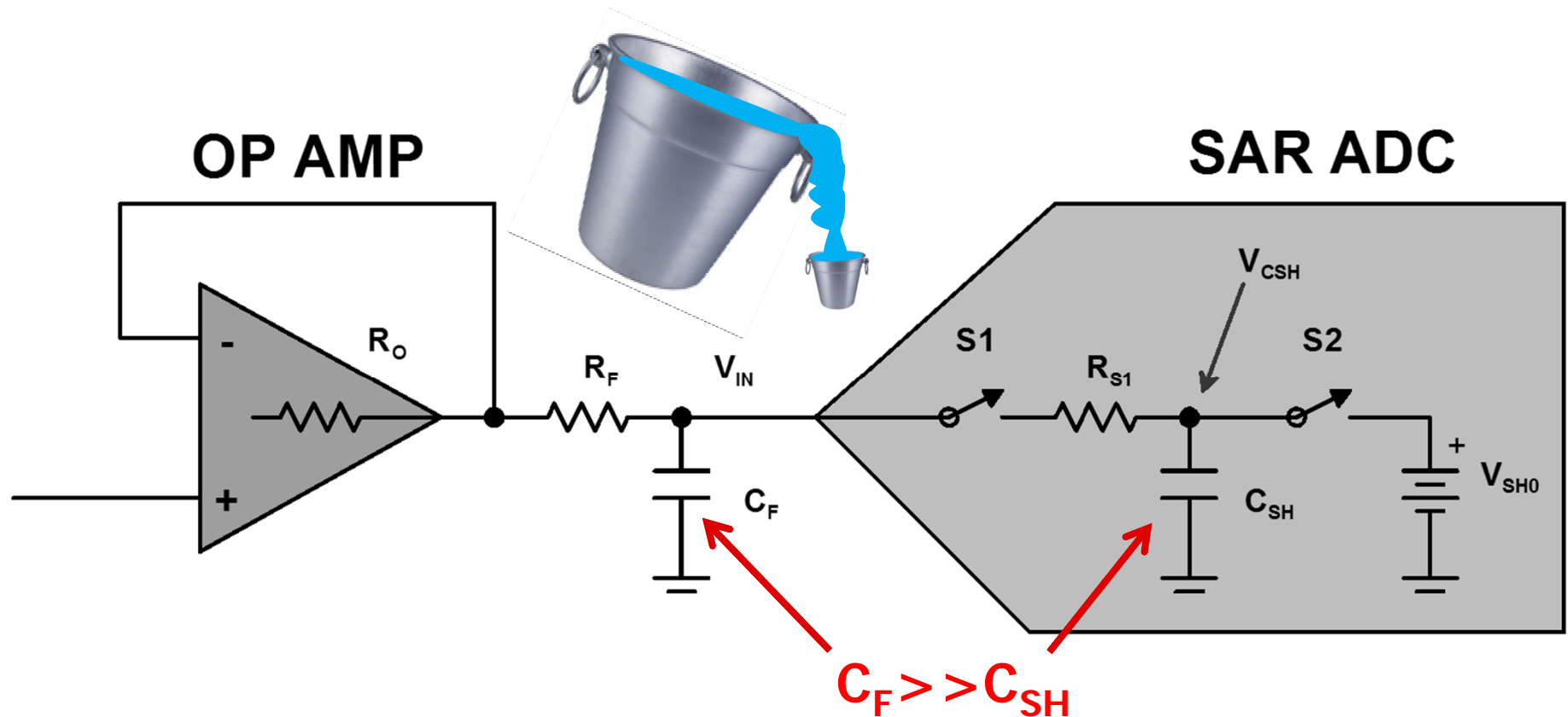

Making  $C_F$  large causes the charge transfer from  $C_F$  to  $C_{SH}$  to have minimal effect on  $C_F$  voltage

# Op Amp Stability

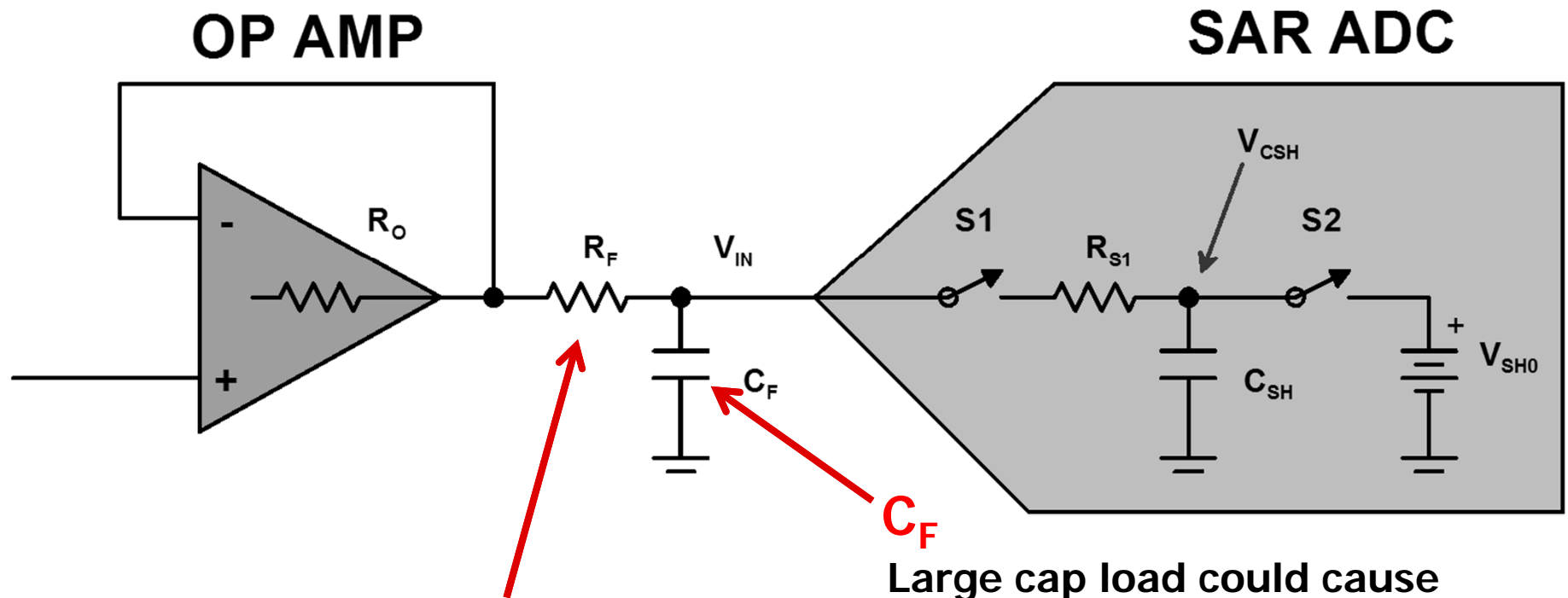

## Isolation Resistor

Stabilizes op amp by isolating it from the capacitive load.

In addition, the RC network slows the load transient seen by the op amp and provides high frequency noise filtering.