

ADC 1

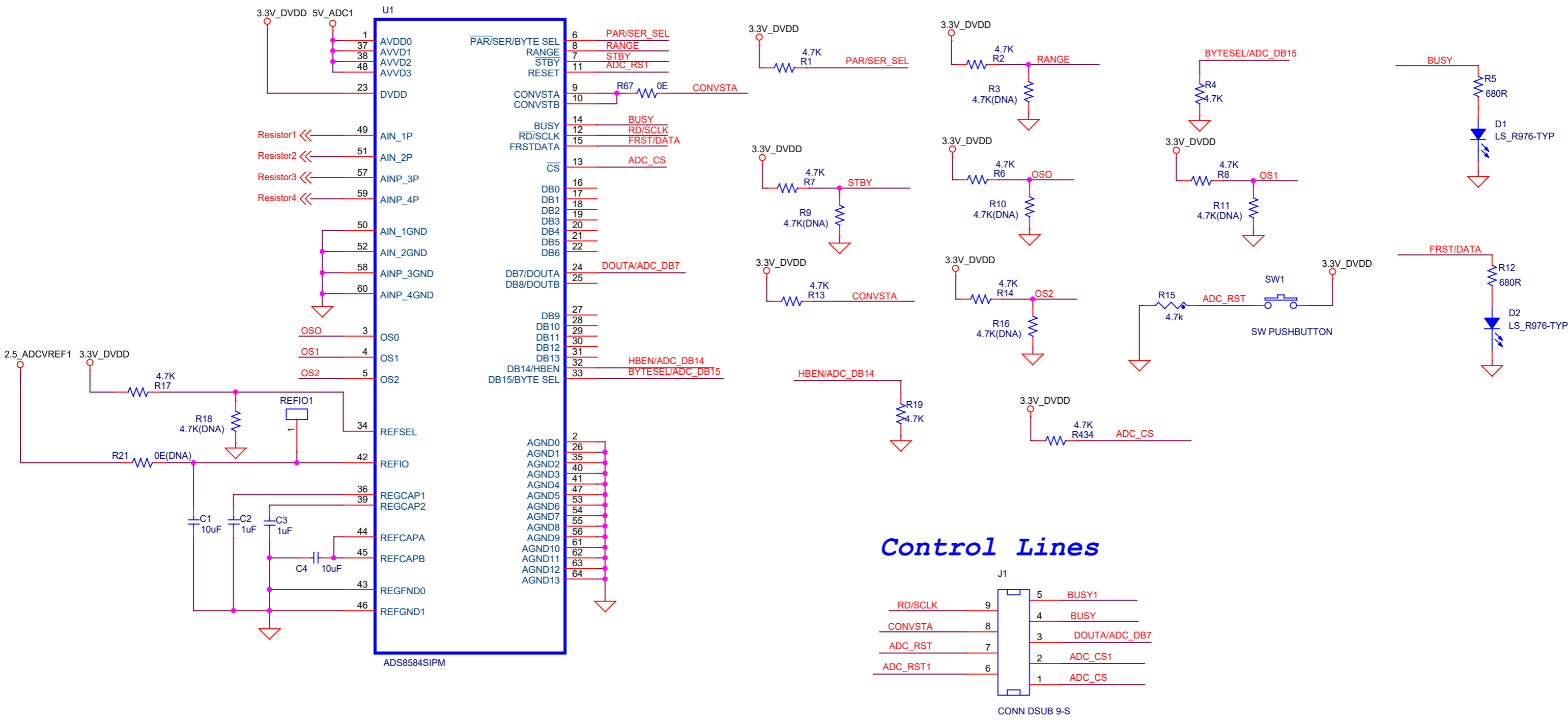

Control Lines

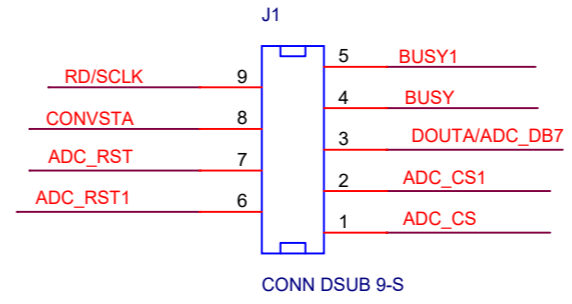

Title		
<Title>		
Size	Document Number	Rev
B	<Doc>	<RevCode>
Date:	Thursday, November 30, 2023	Sheet 1 of 1