

# Buttons & Switches

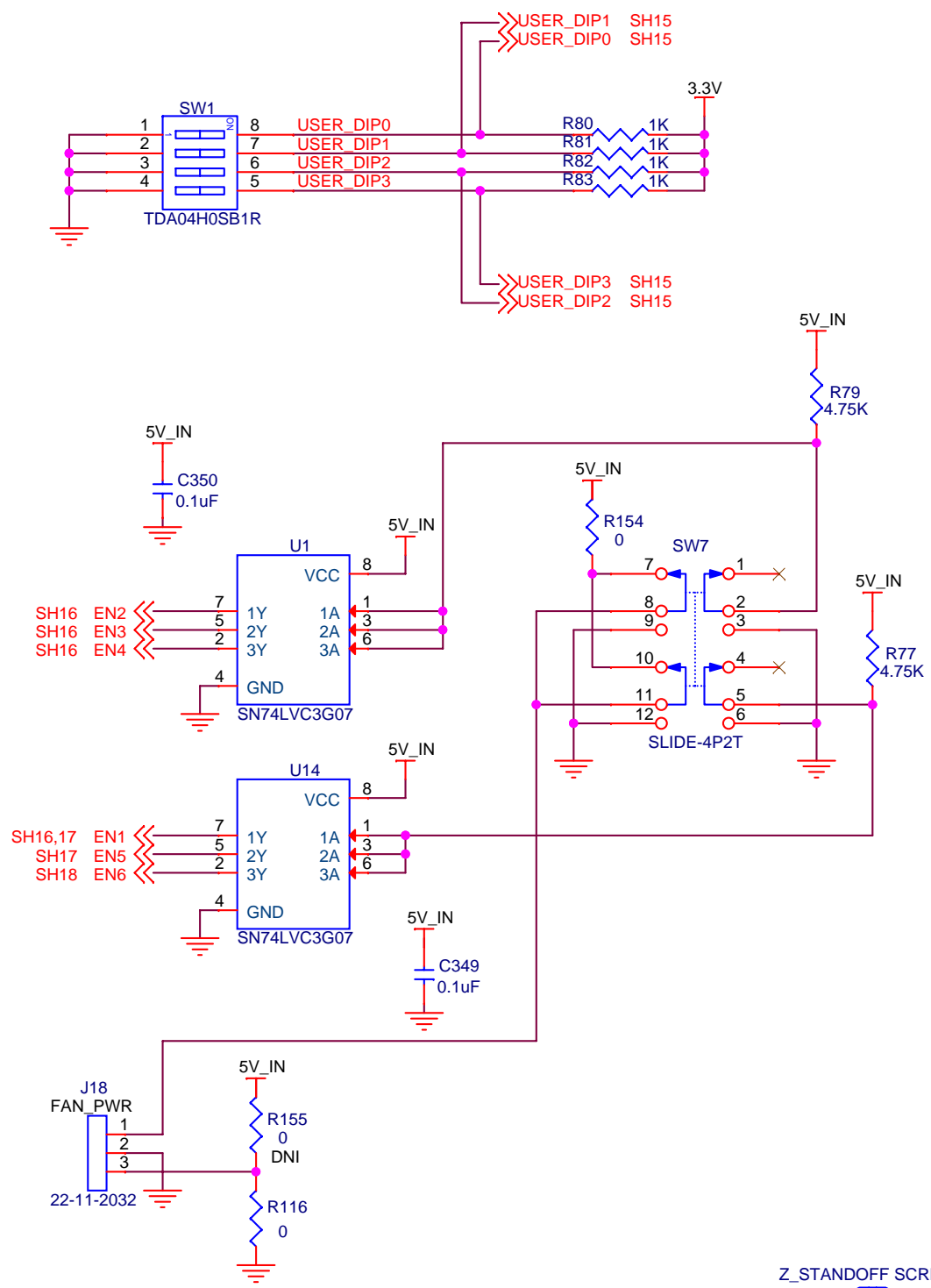

# LEDs

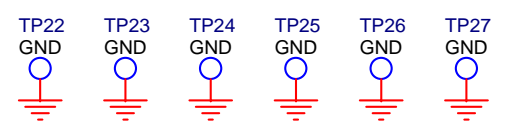
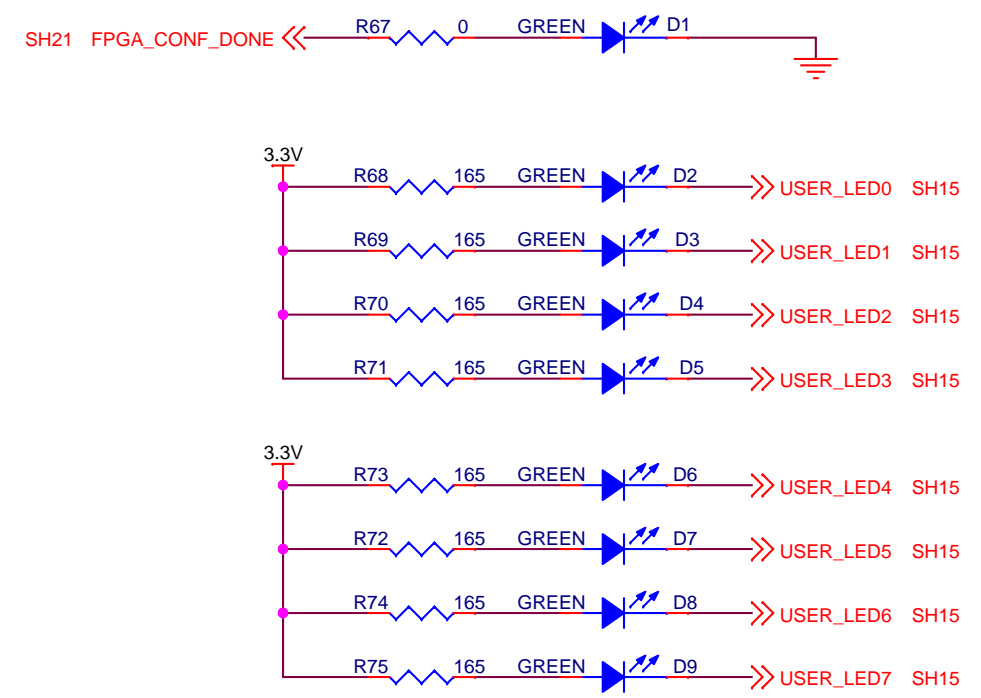

# MECHANICAL PARTS

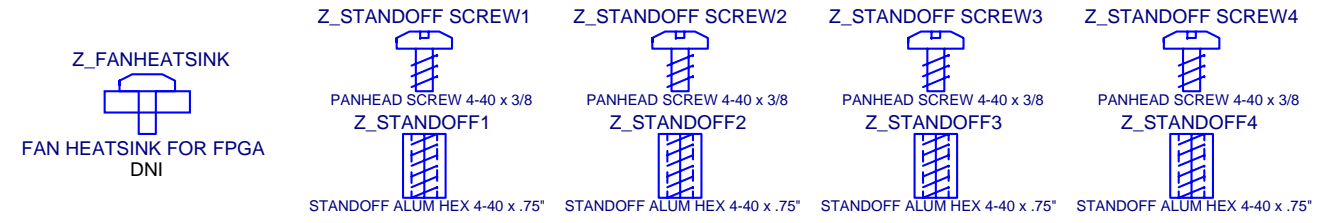

Title		
<b>BUTTONS, SWITCHES, LEDS</b>		
Size	Document Number	Rev
<b>B</b>	<b>TSW1400</b>	<b>D</b>
Date:	Wednesday, January 04, 2012	Sheet 1 of 21

Drawn: P. LARSON  
 Engineer: J. SETON

# CMOS Header

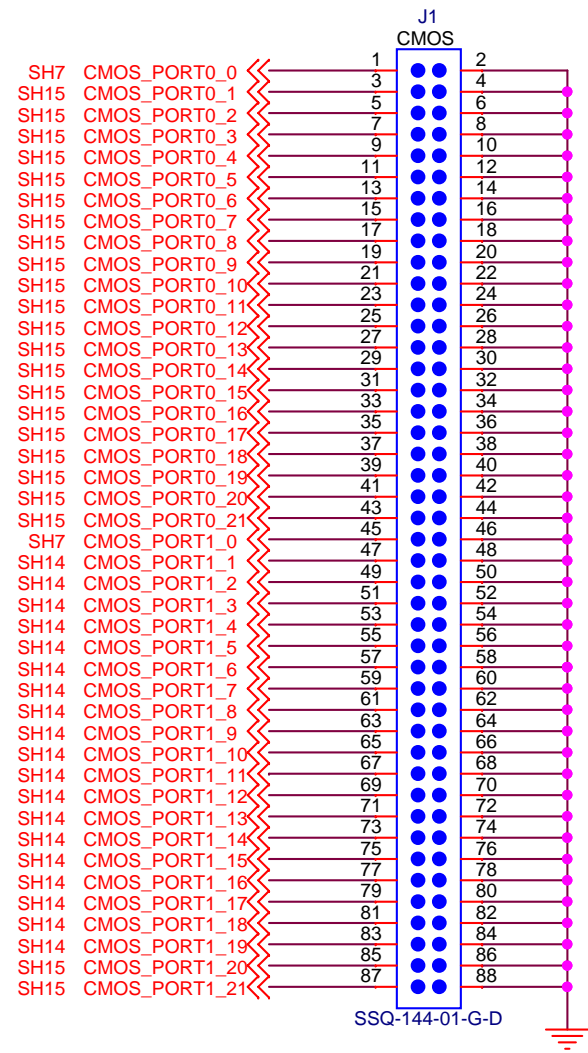

Title		
<b>CMOS Header</b>		
Size	Document Number	Rev
<b>B</b>	<b>TSW1400</b>	<b>D</b>
Date:	Wednesday, January 04, 2012	Sheet 2 of 21

# ADC Interface

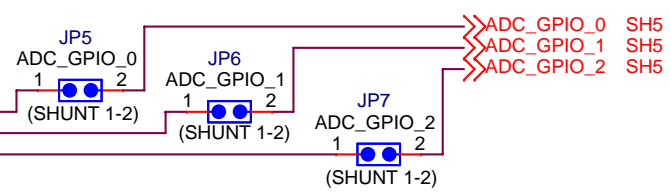
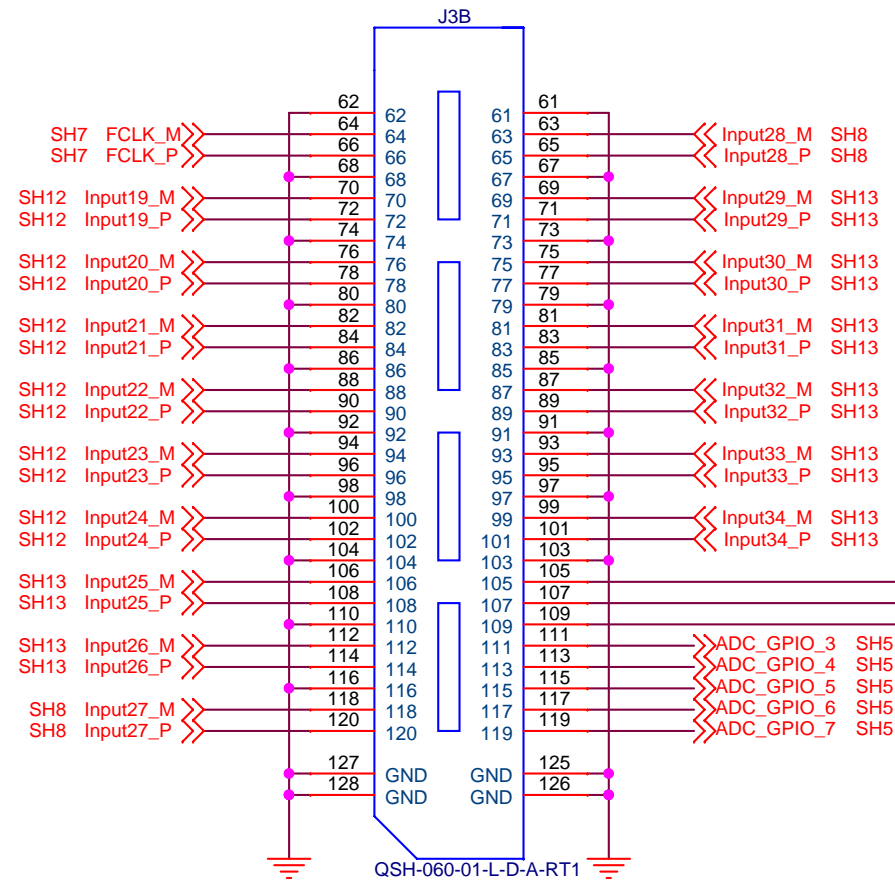
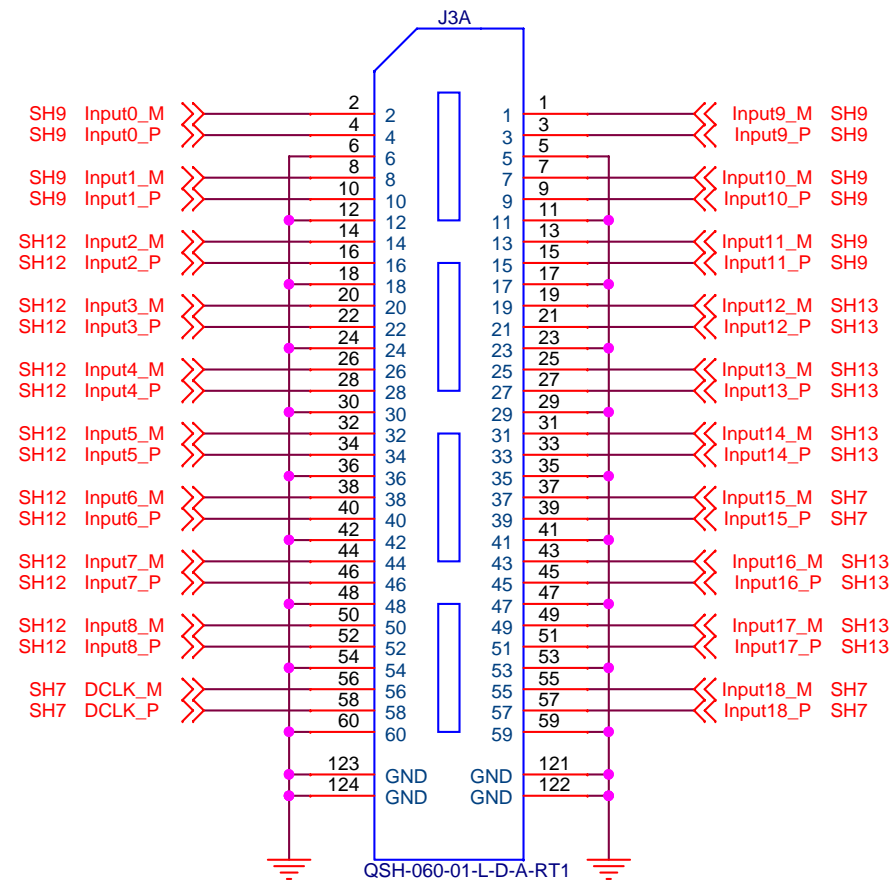

# JESD

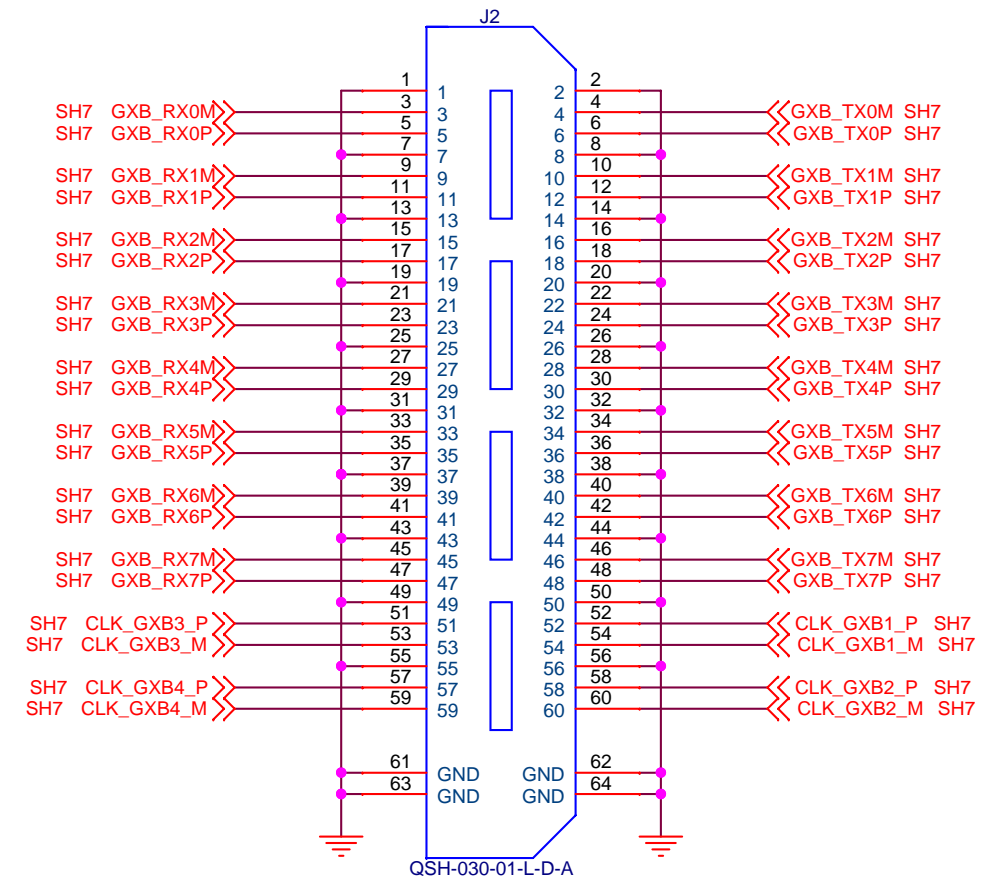

**TEXAS INSTRUMENTS**

Title: **ADC & JESD INTERFACE**

Size: <b>B</b>	Document Number: <b>TSW1400</b>	Rev: <b>D</b>
Date: Wednesday, January 04, 2012	Sheet: 3 of 21	

# DAC Interface

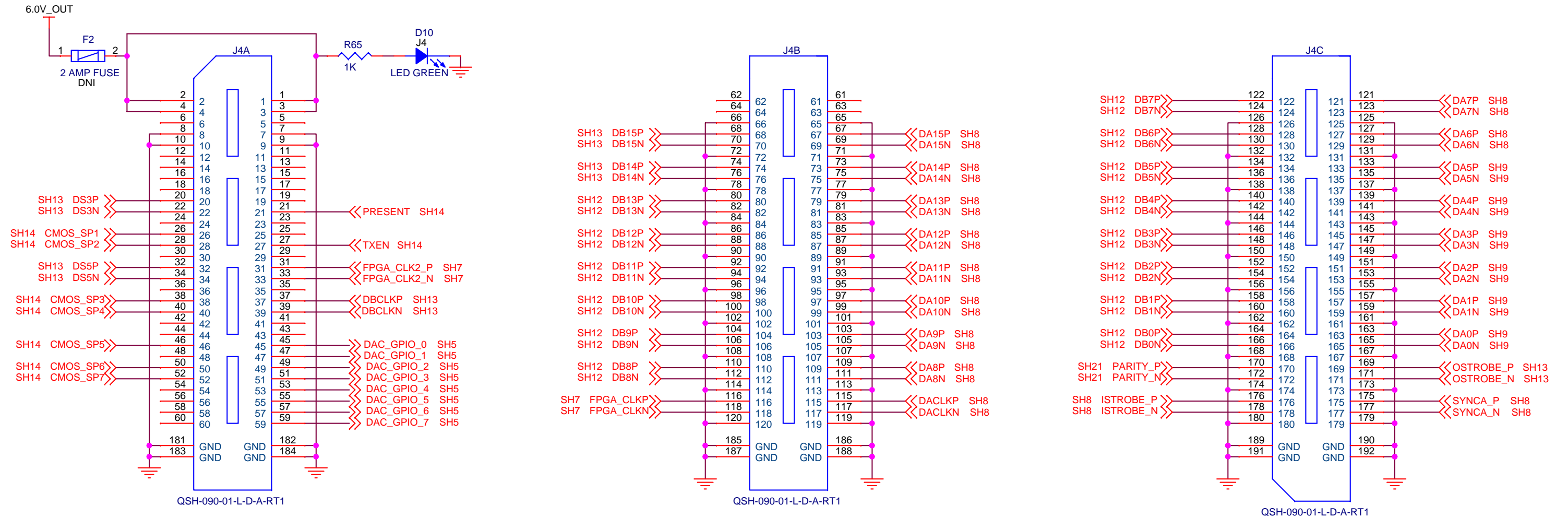

# USB

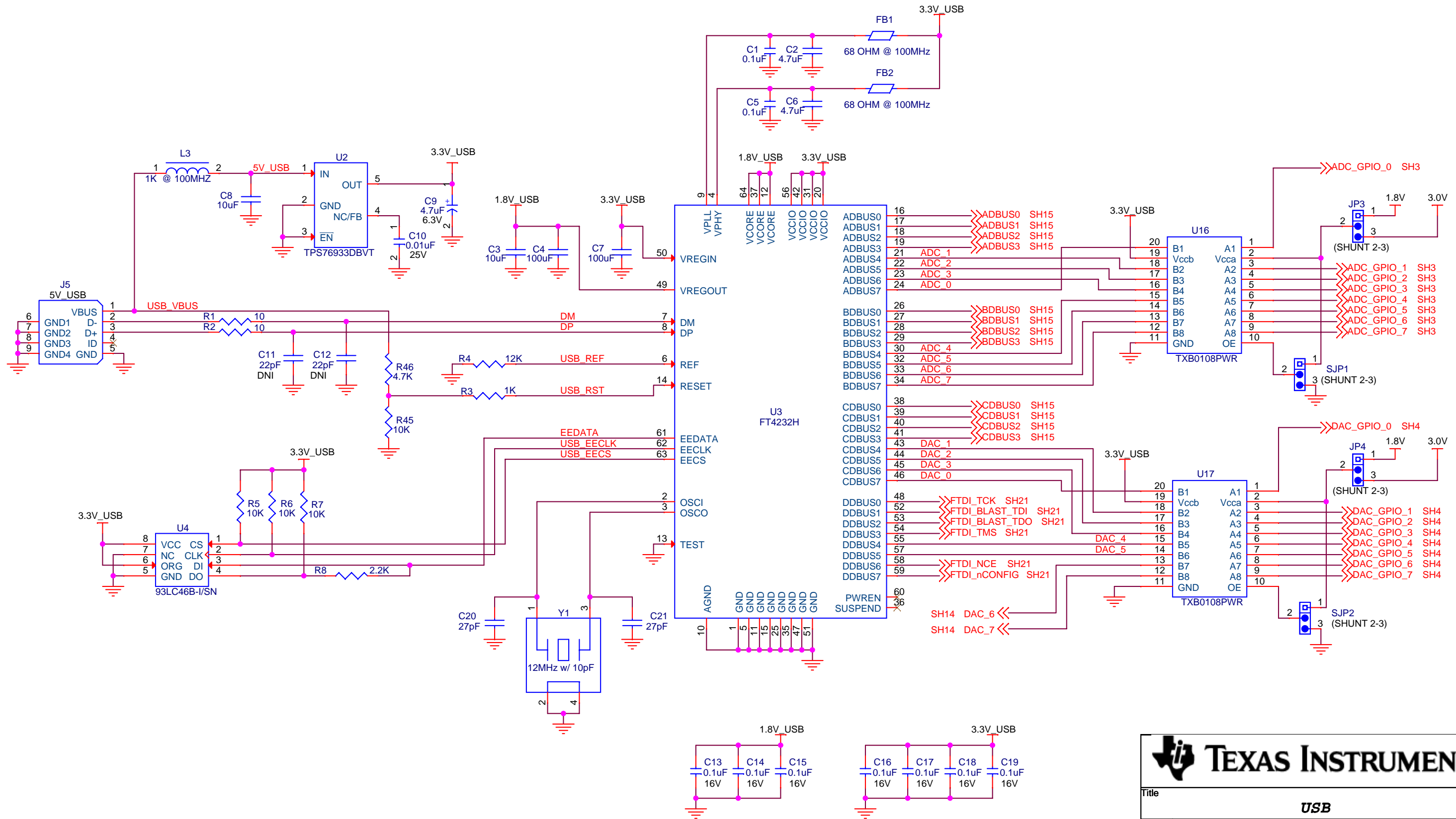
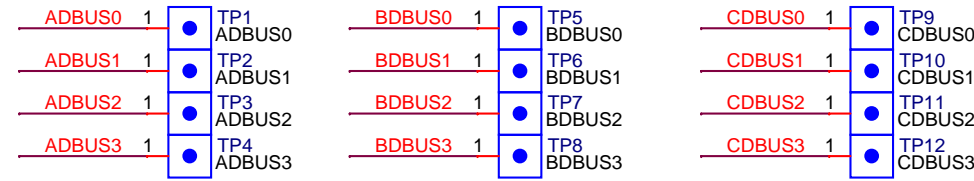

**TEXAS INSTRUMENTS**  
 Title: **USB**  
 Size: **B** Document Number: **TSW1400** Rev: **D**  
 Date: Wednesday, January 04, 2012 Sheet 5 of 21

# DDR2 SO-DIMM

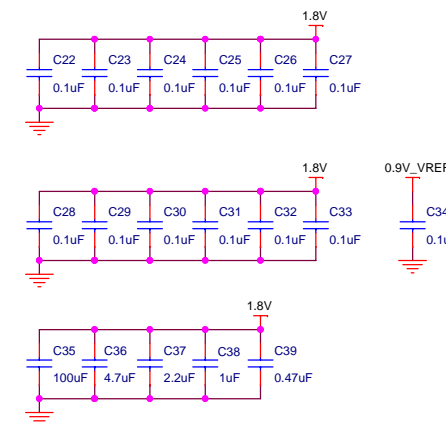
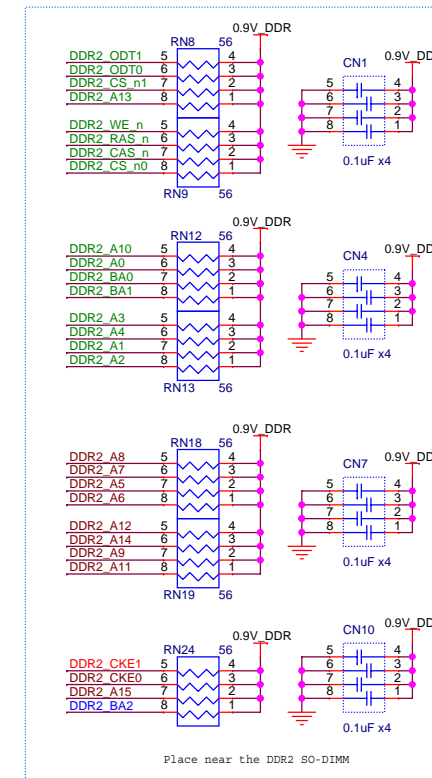



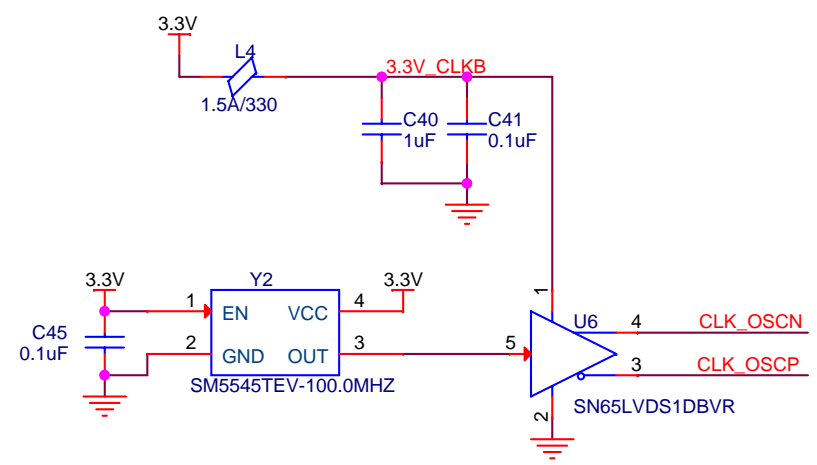
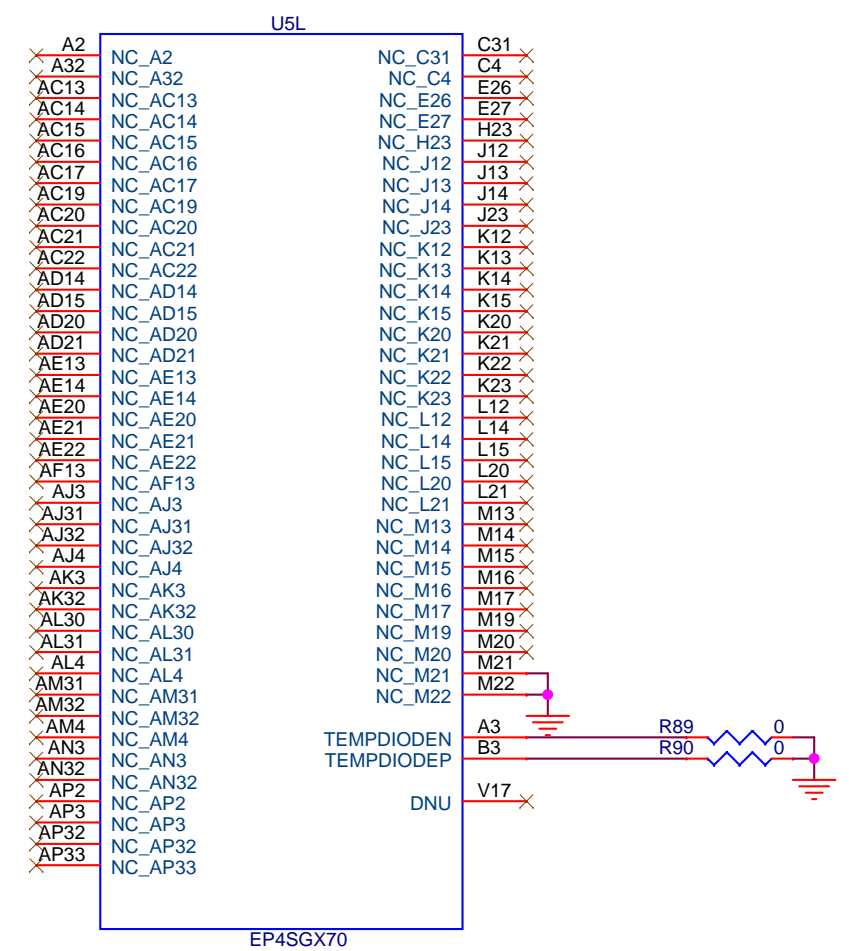

# BANK QL

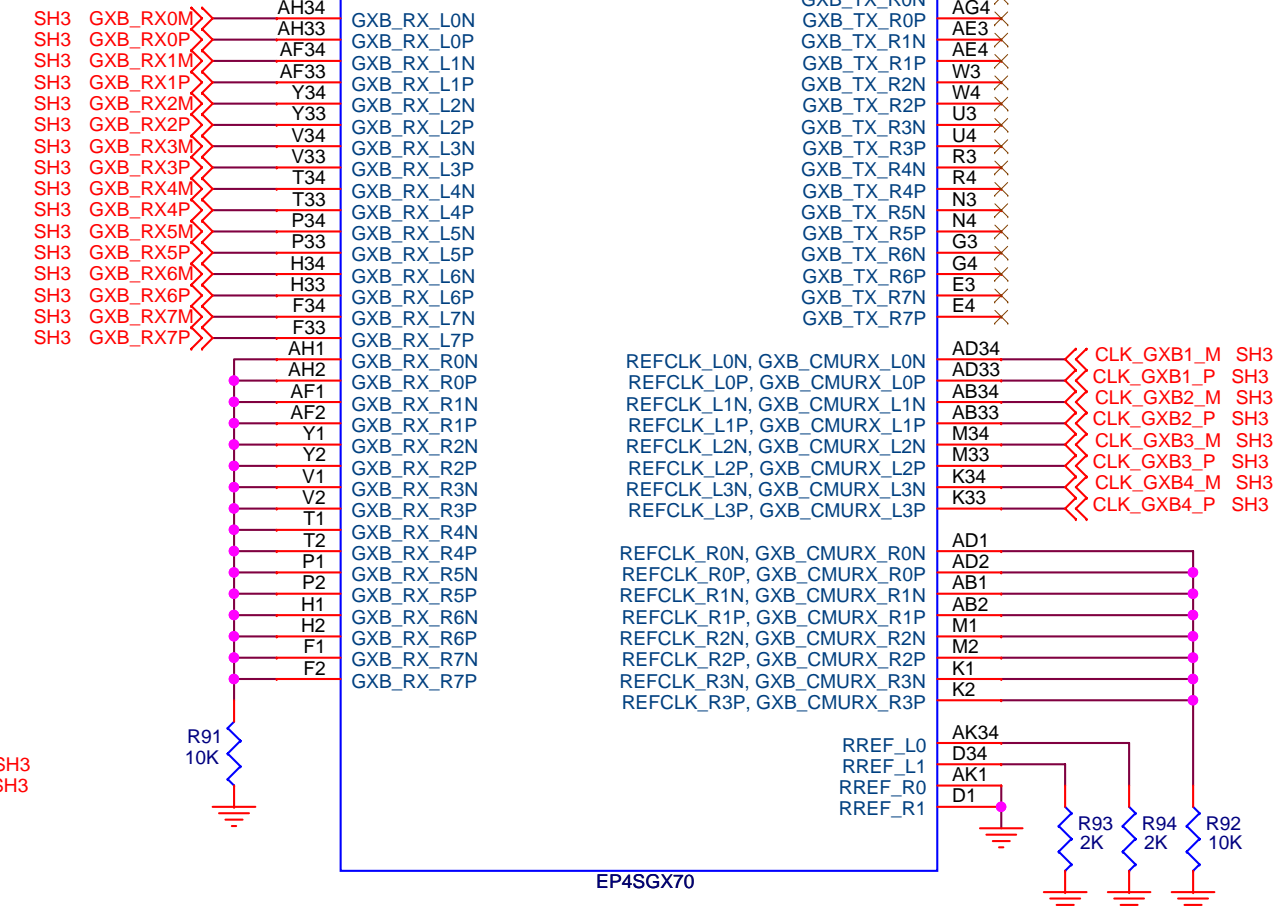
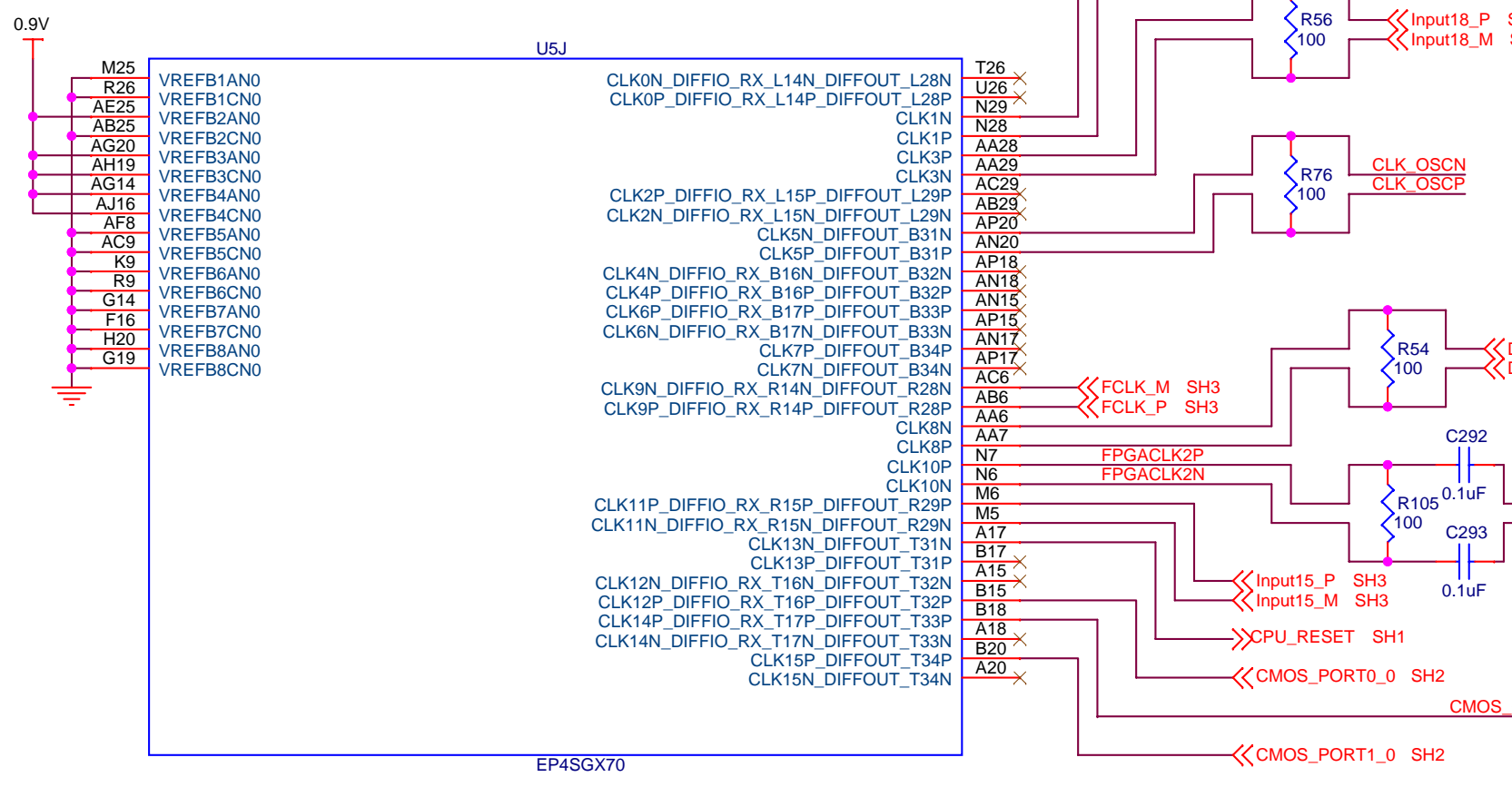
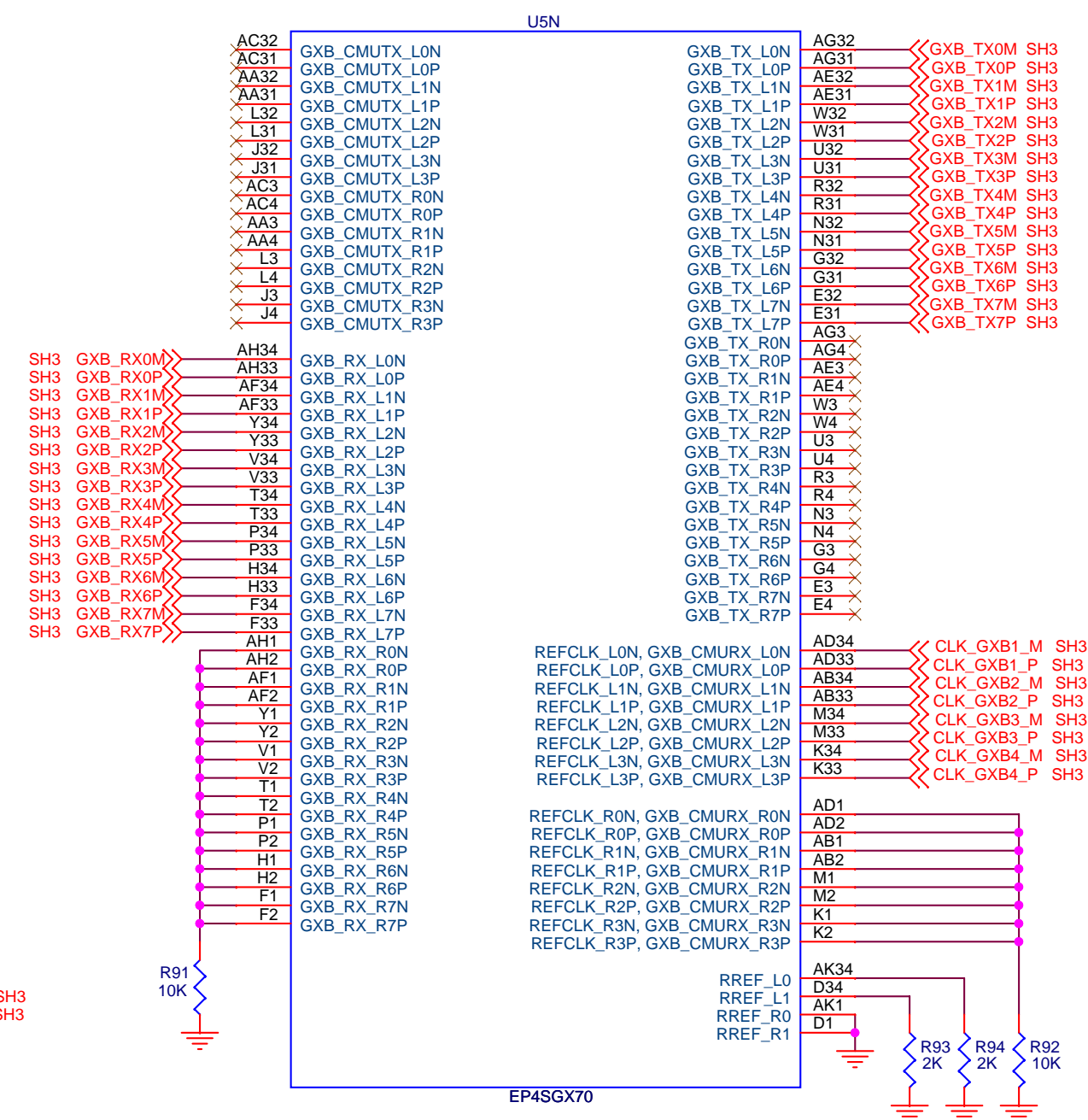

**TEXAS INSTRUMENTS**

Title: **Bank QL**

Size: **B** | Document Number: **TSW1400** | Rev: **D**

Date: **Wednesday, January 04, 2012** | Sheet: **7** of **21**

# BANK1

## 2.5V

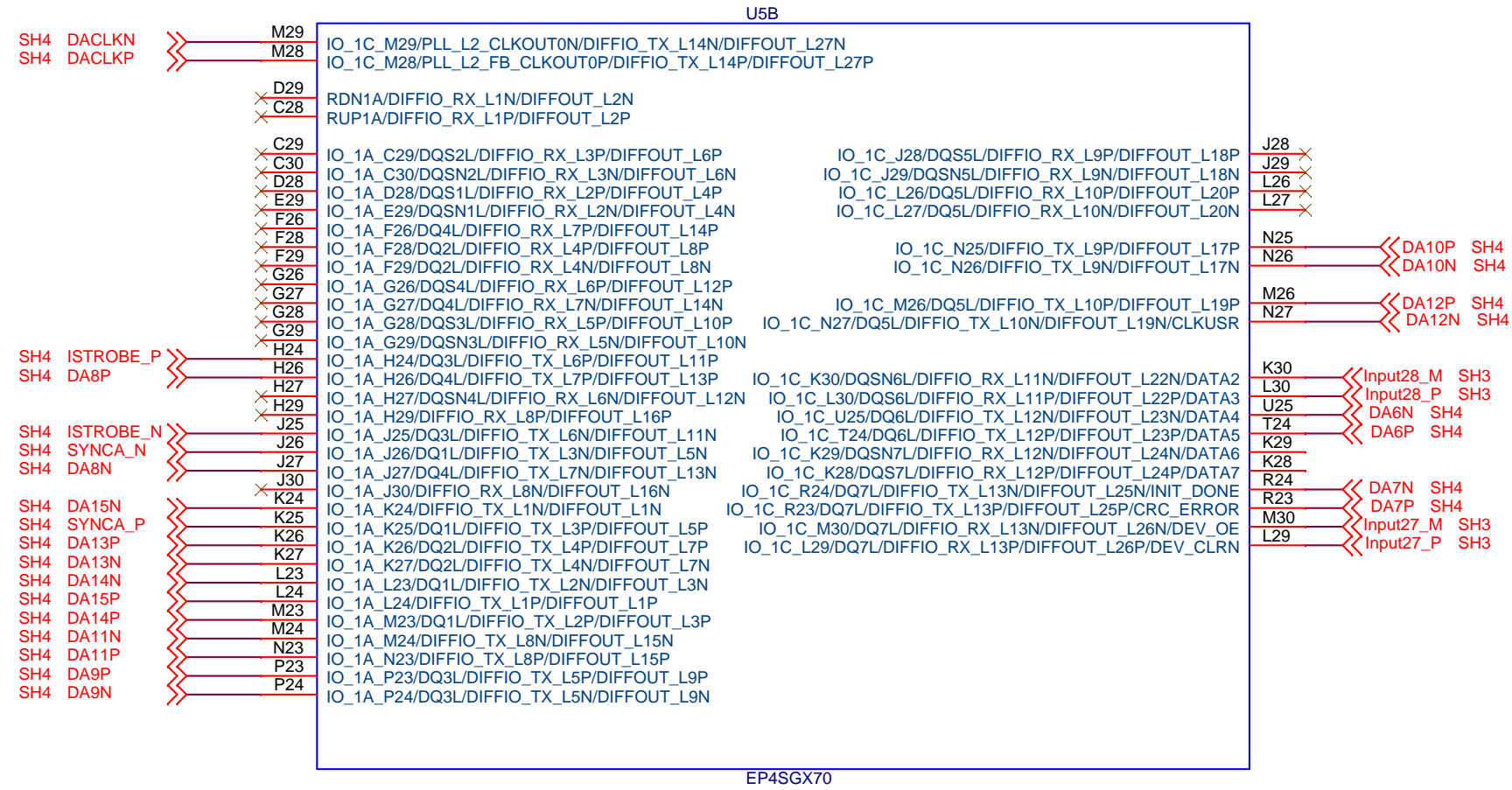

Title		
<b>Bank1</b>		
Size	Document Number	Rev
<b>B</b>	<b>TSW1400</b>	<b>D</b>
Date:	Wednesday, January 04, 2012	Sheet 8 of 21



# BANK2

1.8V

2.5V

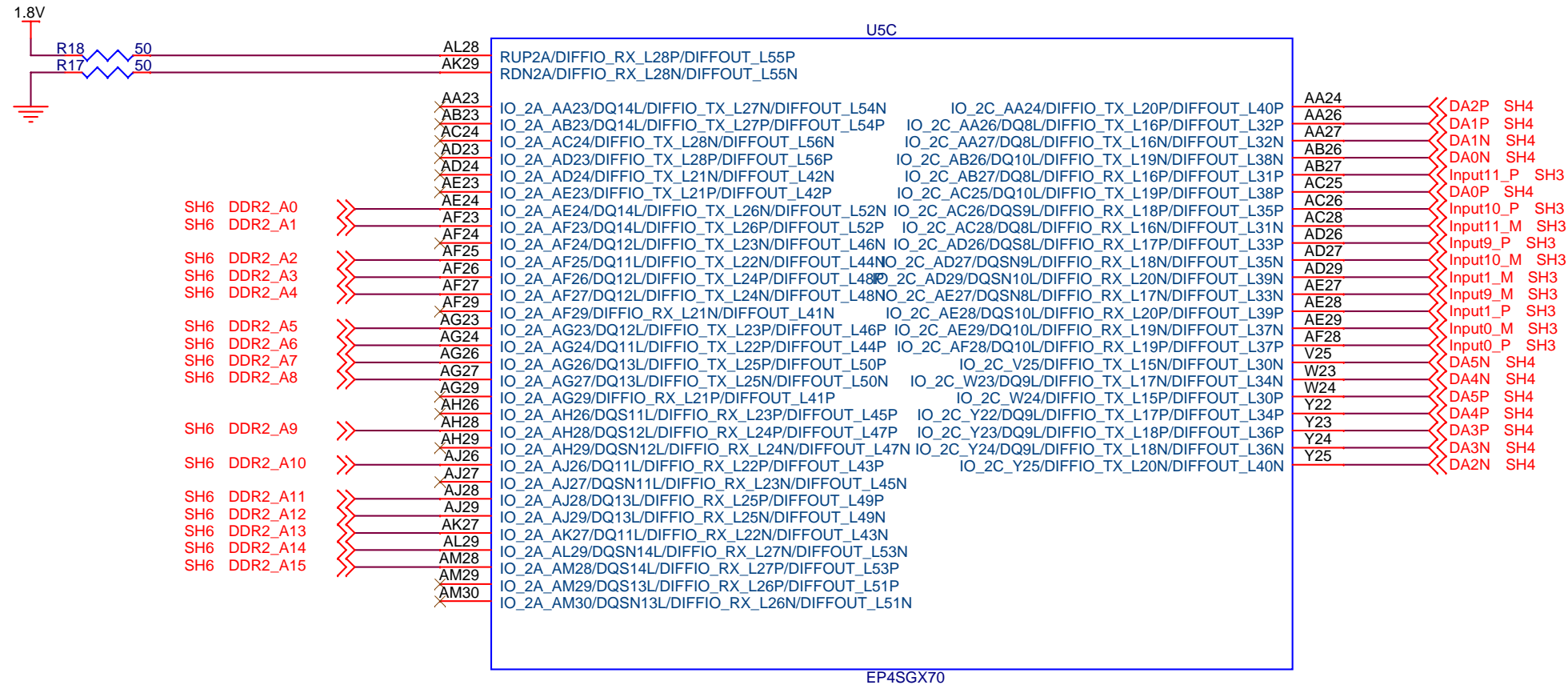

**TEXAS INSTRUMENTS**

Title: **Bank2**

Size: **B** | Document Number: **TSW1400** | Rev: **D**

Date: **Wednesday, January 04, 2012** | Sheet: **9** of **21**

# BANK3

## 1.8V

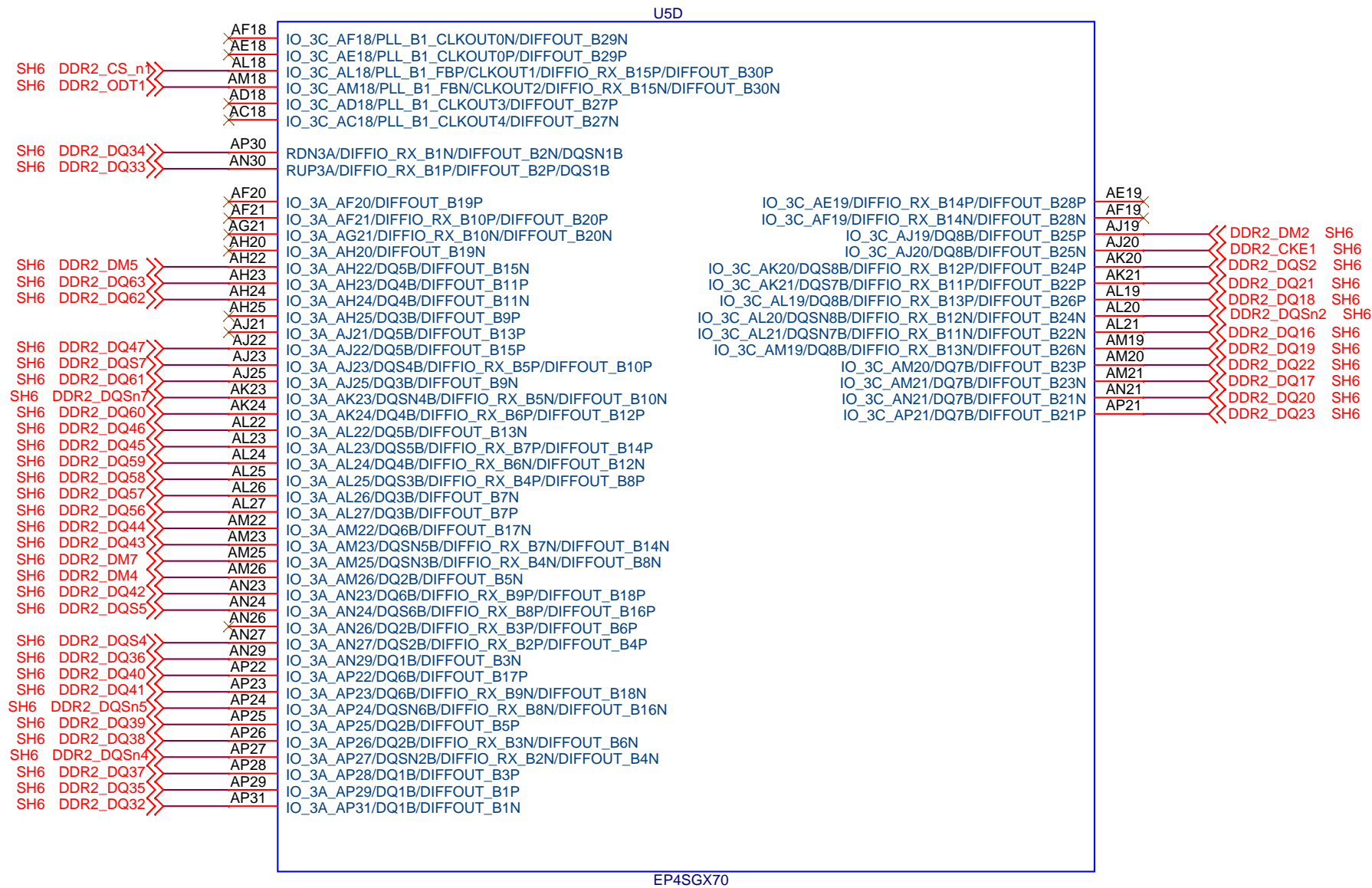

**TEXAS INSTRUMENTS**

Title		
<b>Bank3</b>		
Size	Document Number	Rev
<b>B</b>	<b>TSW1400</b>	<b>D</b>
Date:	Wednesday, January 04, 2012	Sheet 10 of 21

# BANK4

## 1.8V

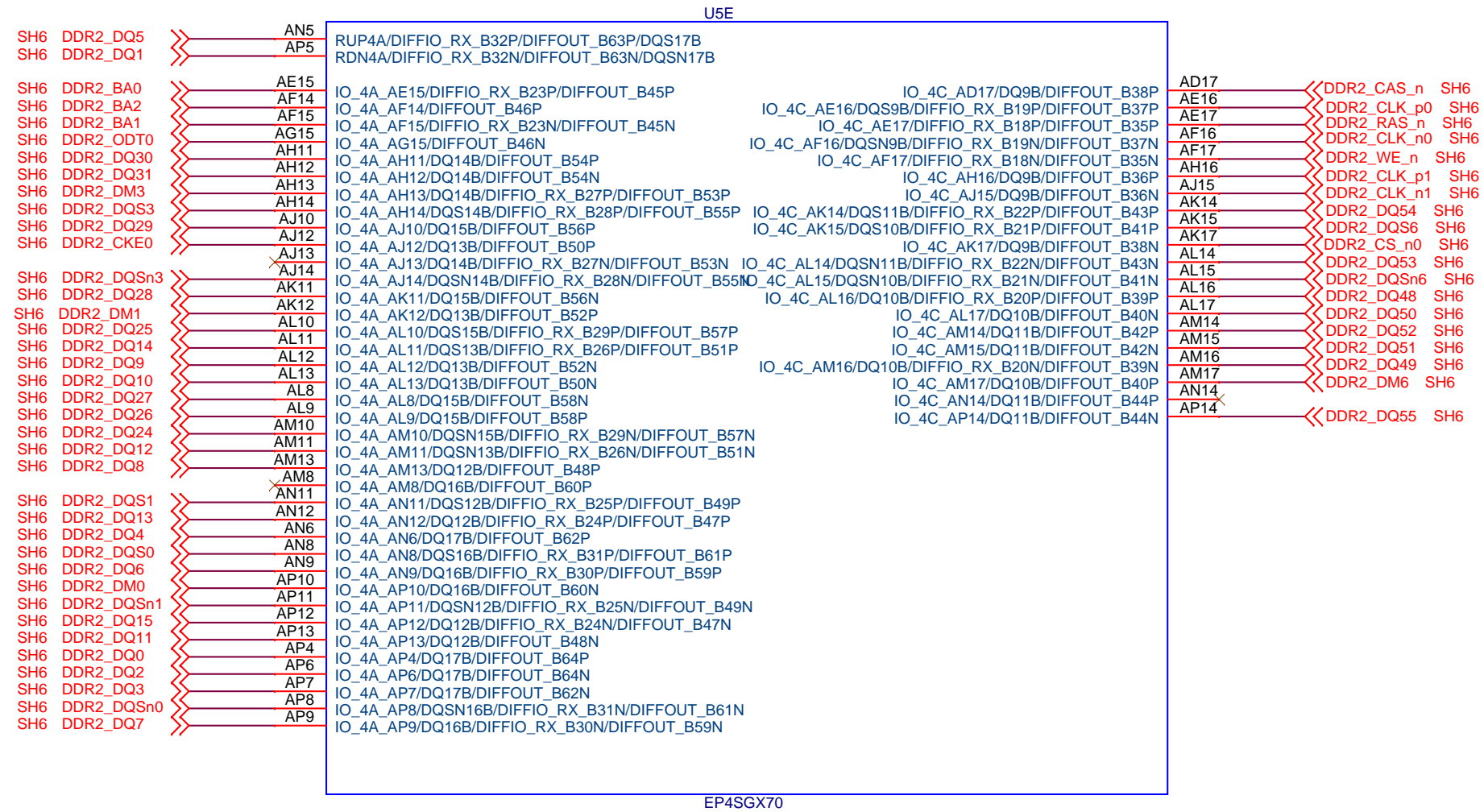

**TEXAS INSTRUMENTS**

Title		
<b>Bank4</b>		
Size	Document Number	Rev
<b>B</b>	<b>TSW1400</b>	<b>D</b>
Date:	Wednesday, January 04, 2012	Sheet 11 of 21

# BANK5 2.5V

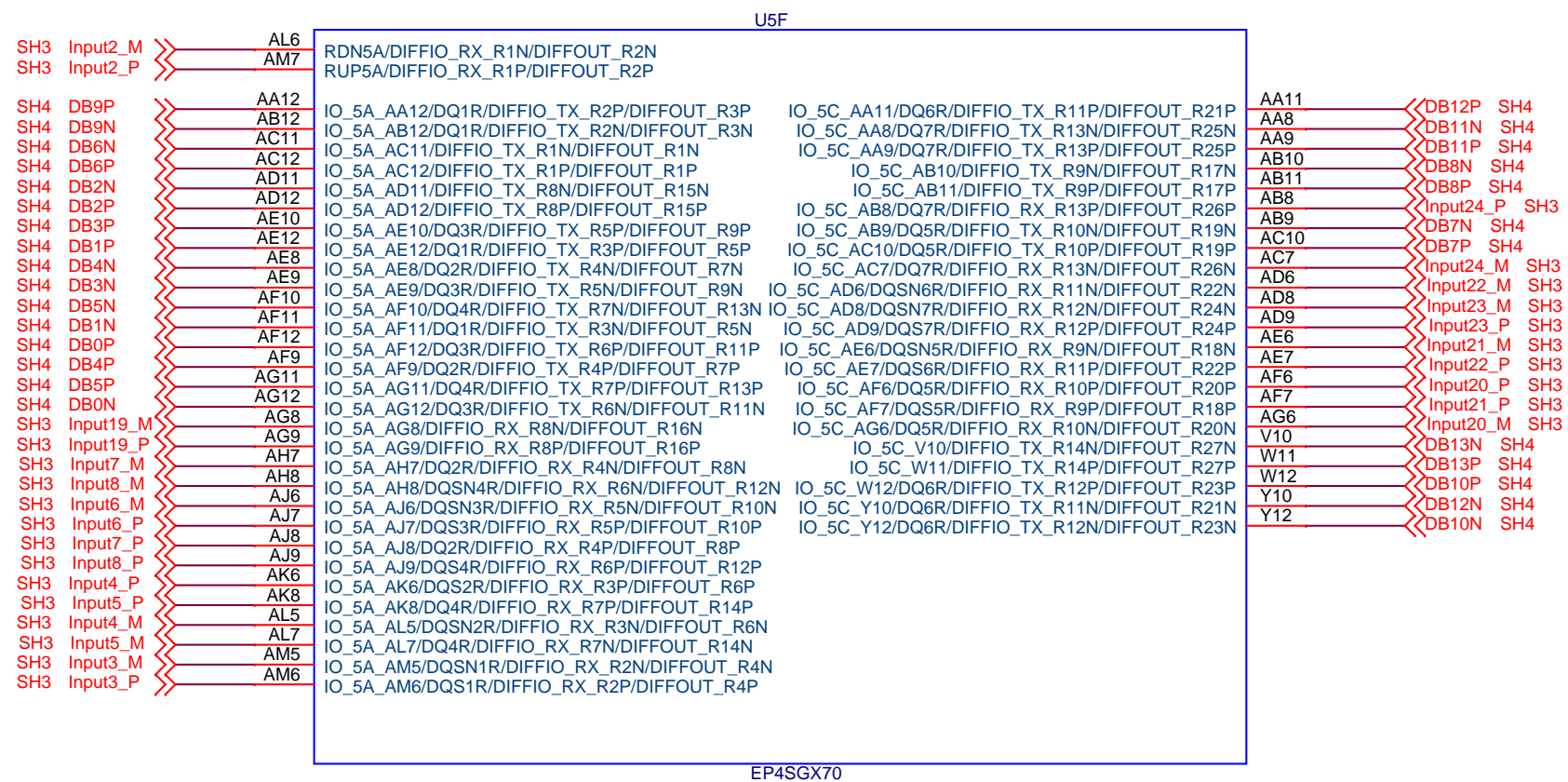

Title		
<b>Bank5</b>		
Size	Document Number	Rev
<b>B</b>	<b>TSW1400</b>	<b>D</b>
Date:	Wednesday, January 04, 2012	Sheet 12 of 21

# BANK6 2.5V

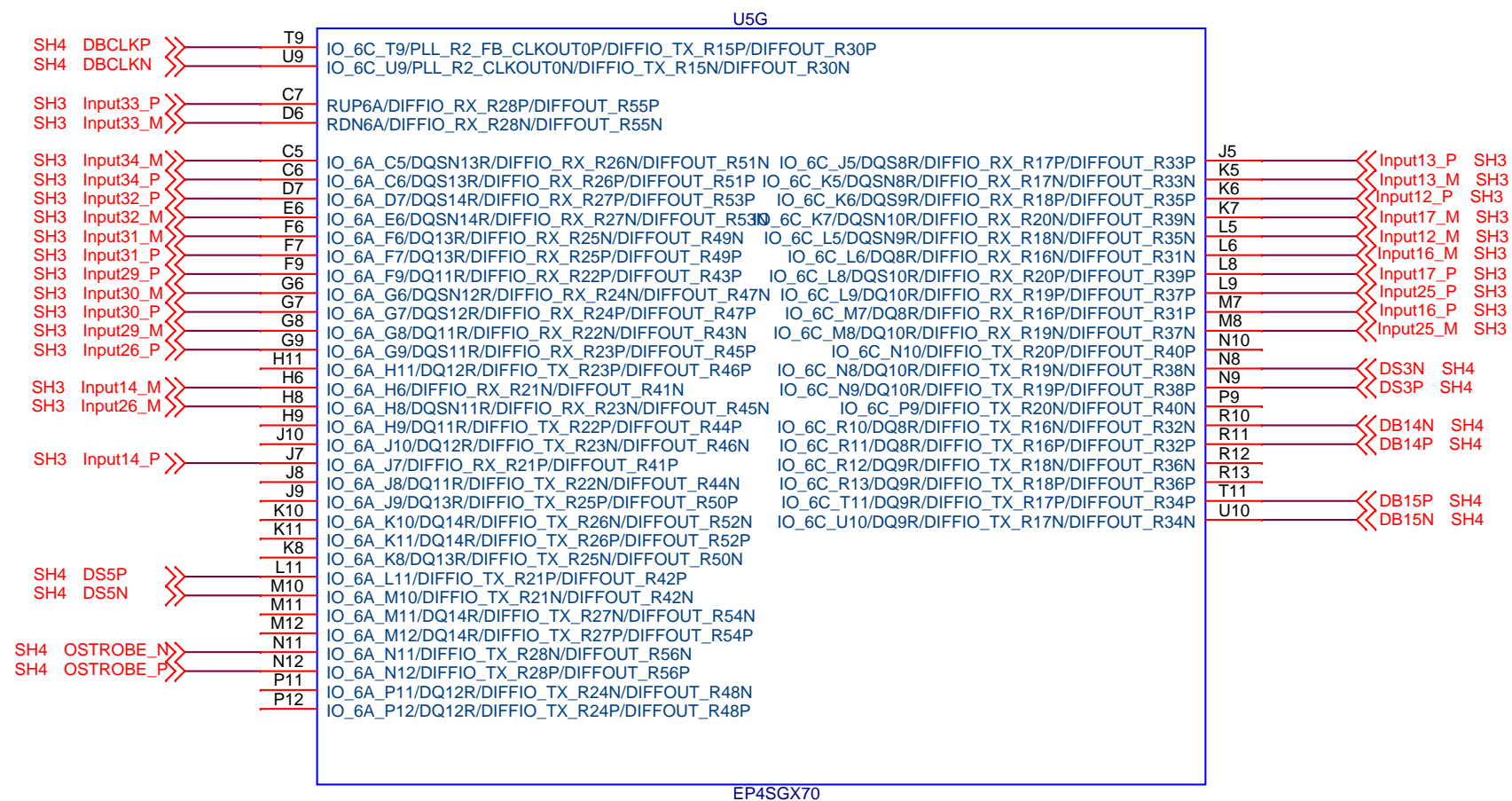

Title		
<b>Bank6</b>		
Size	Document Number	Rev
	<b>TSW1400</b>	<b>D</b>
Date:	Wednesday, January 04, 2012	Sheet 13 of 21



# BANK7

## 3.0V

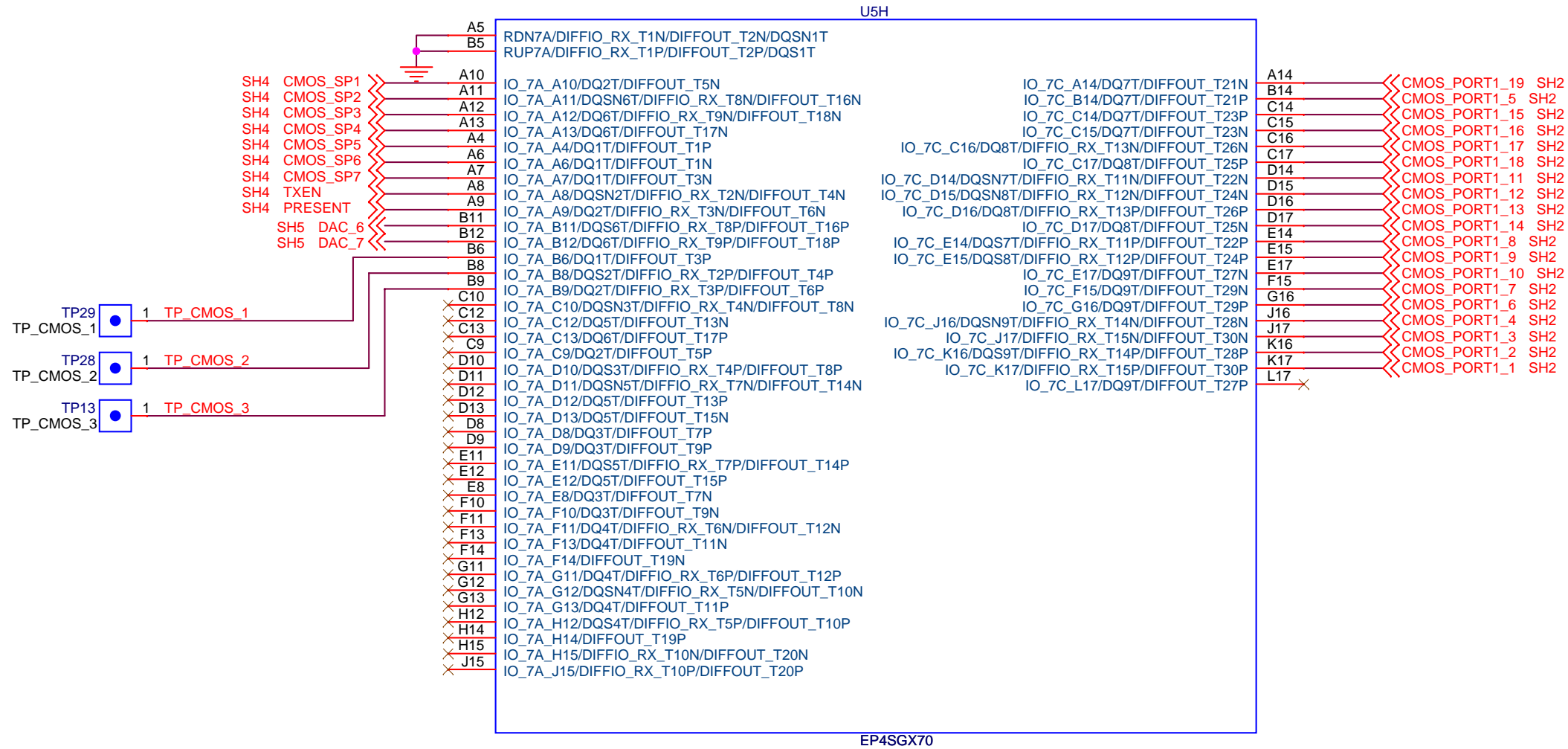

# BANK8

## 3.0V

U51

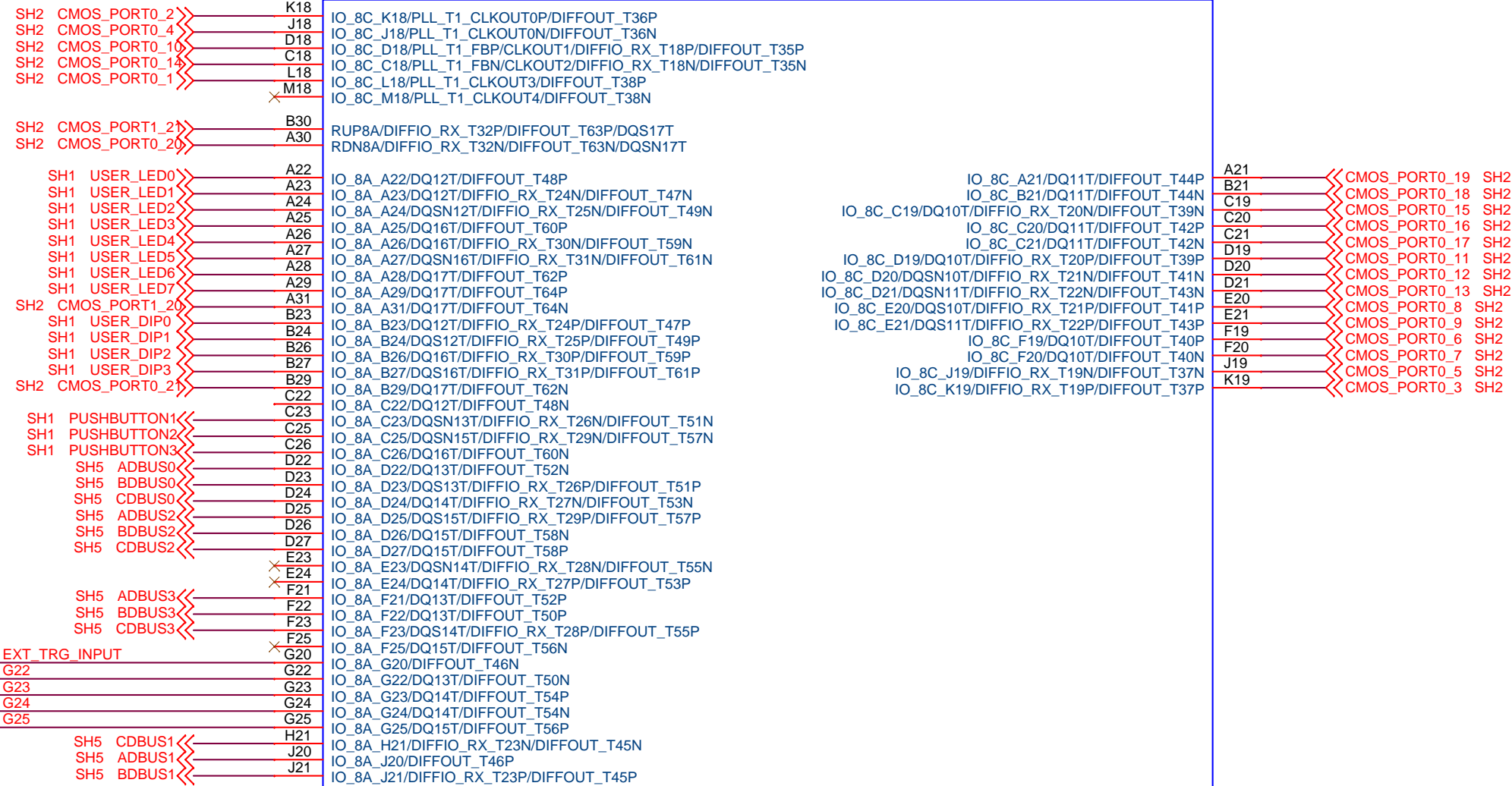

EP4SGX70

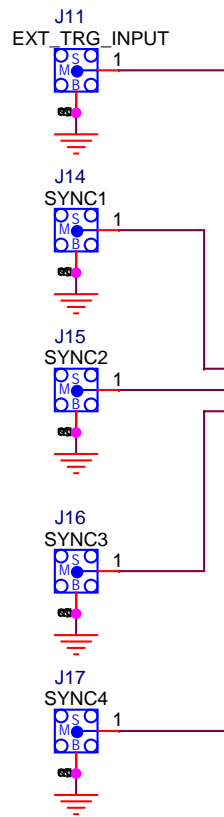

**TEXAS INSTRUMENTS**

Title		
Bank8		
Size	Document Number	Rev
B	TSW1400	D
Date:	Wednesday, January 04, 2012	Sheet 15 of 21

# 0.9V, 1.1V, 1.5V, 1.8V

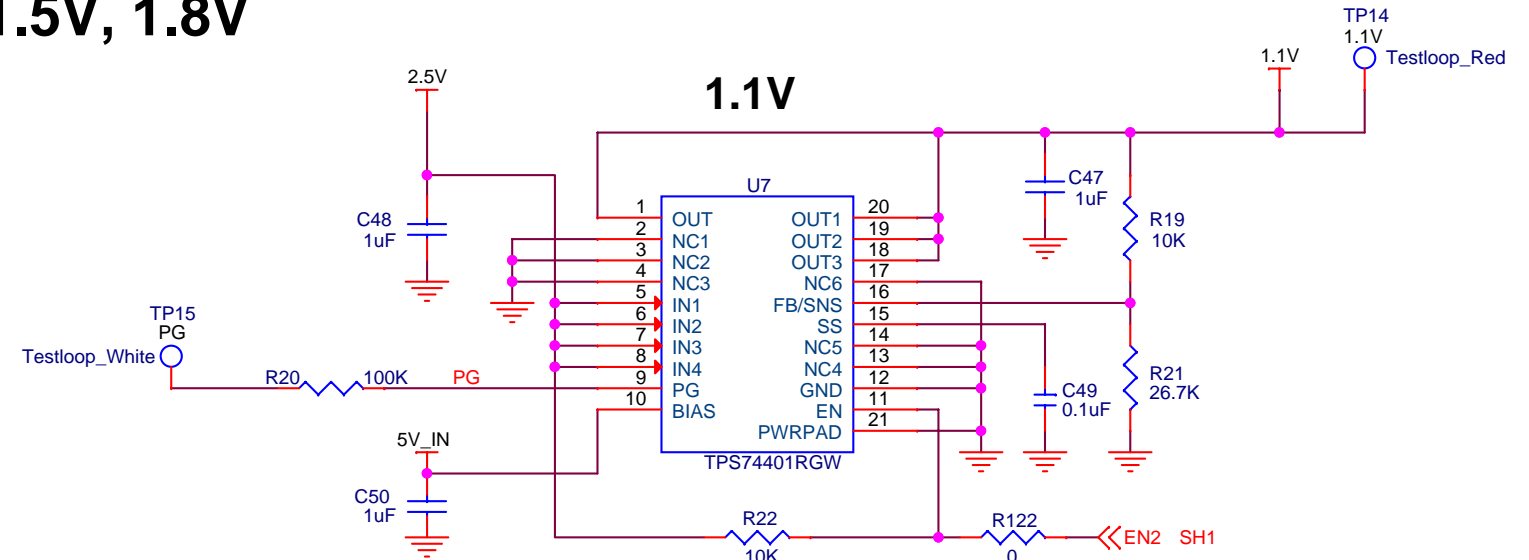
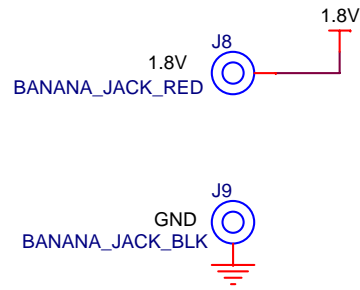

## 0.9V FPGA

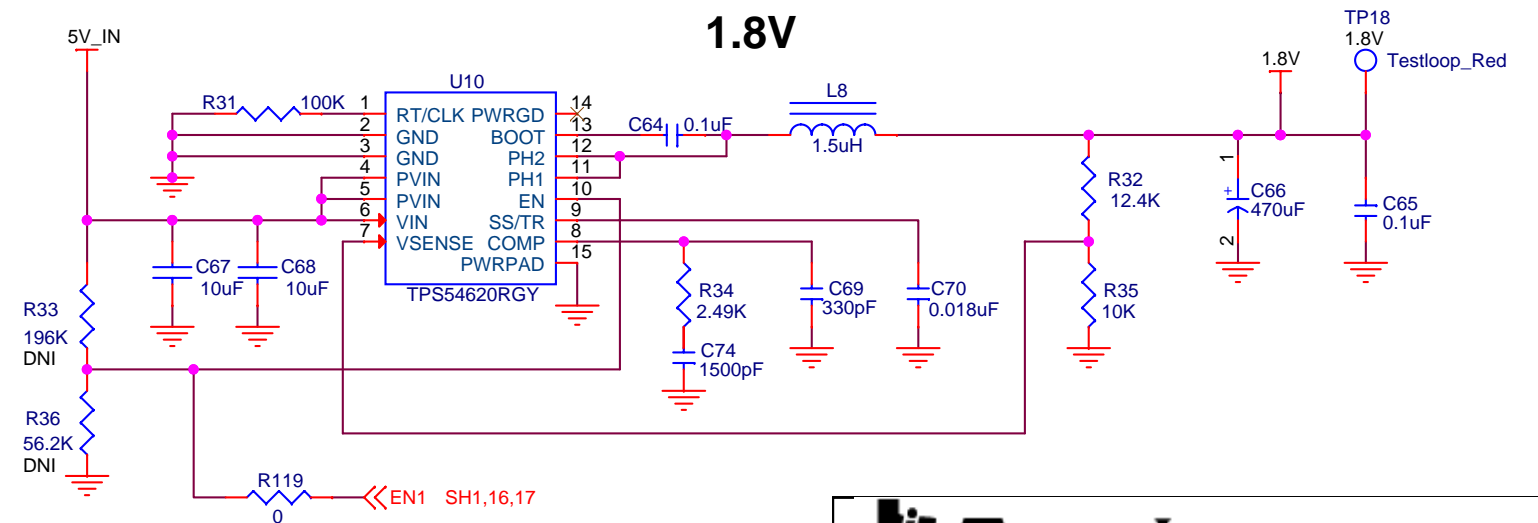
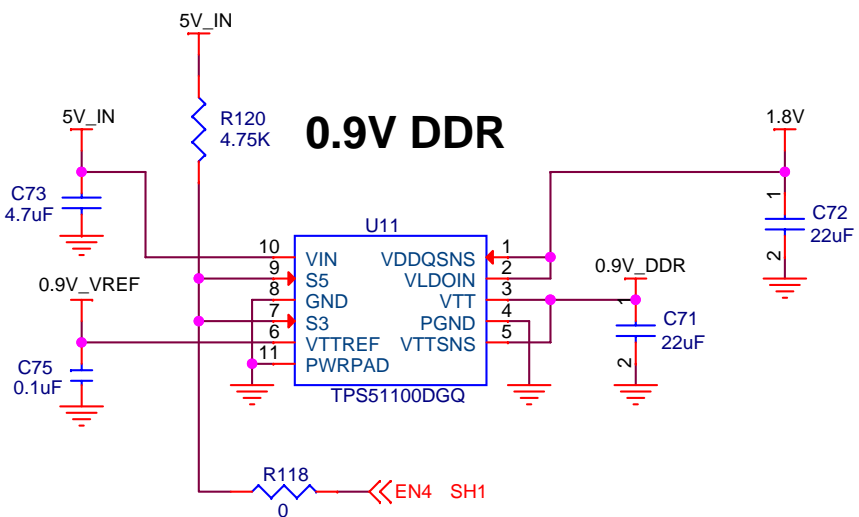
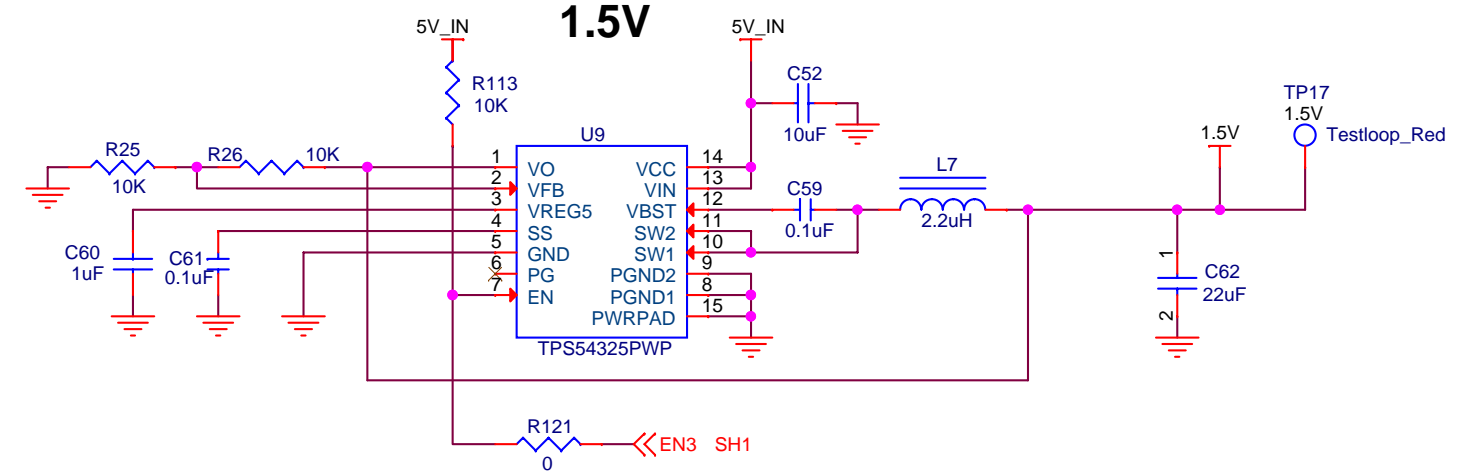
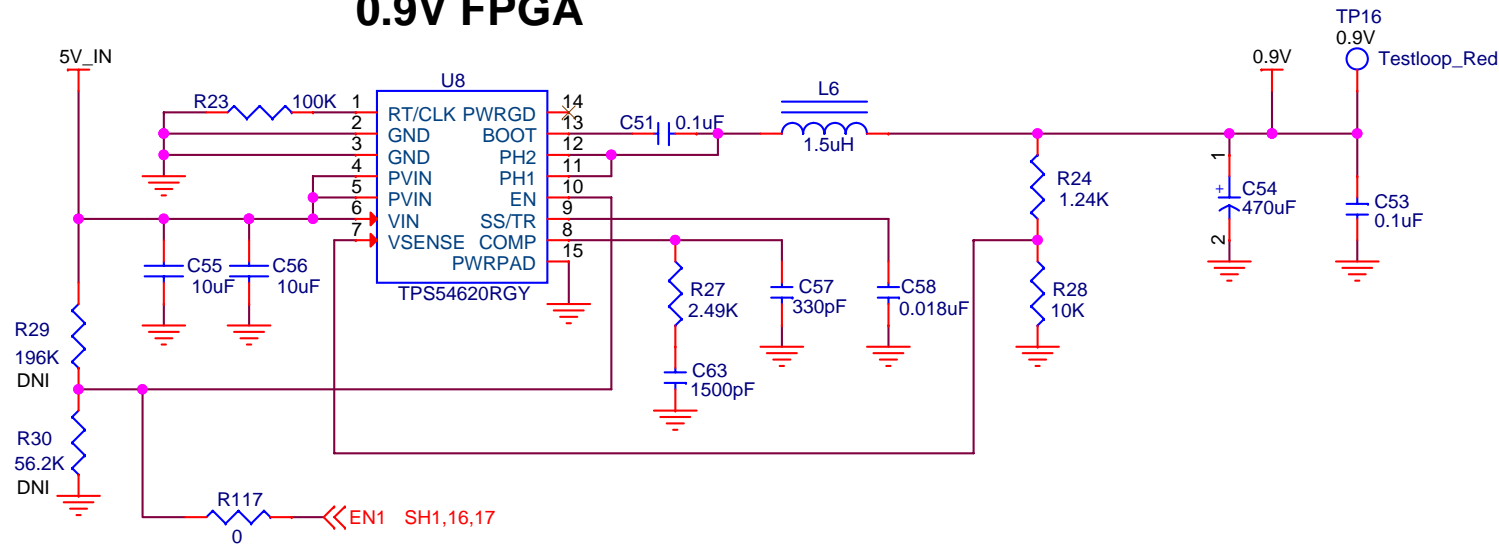

Title		
POWERS 0.9V, 1.1V, 1.5V, 1.8V		
Size	Document Number	Rev
B	TSW1400	D
Date:	Wednesday, January 04, 2012	Sheet 16 of 21

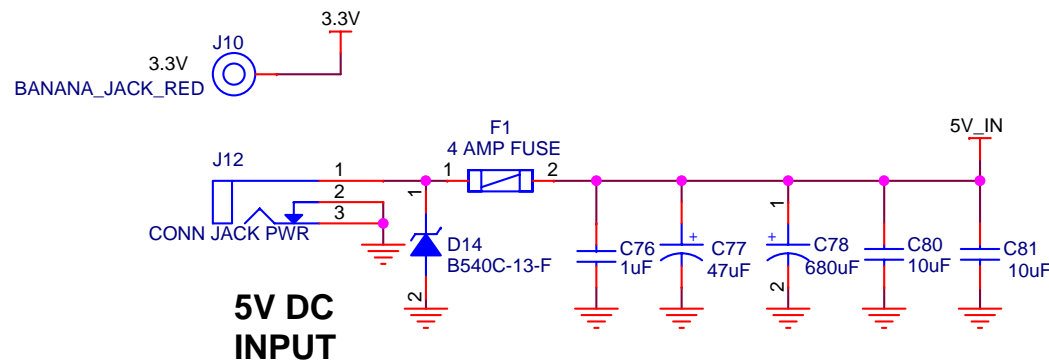

## 2.5V, 3.0V, 3.3V, 5V

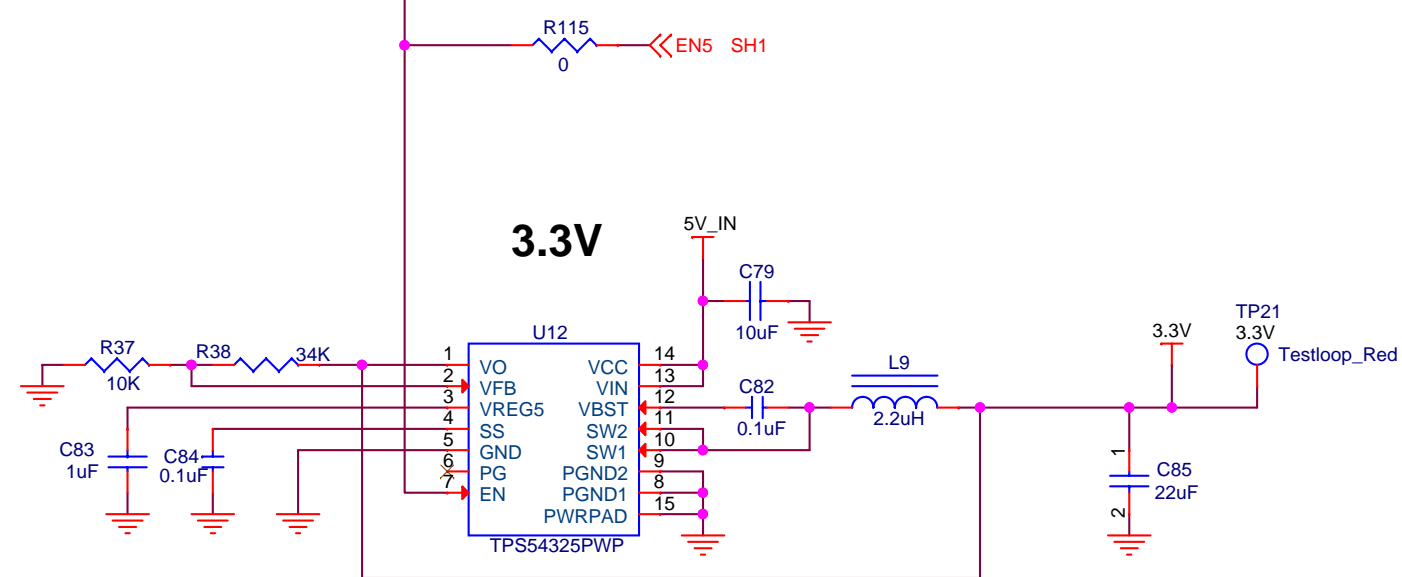
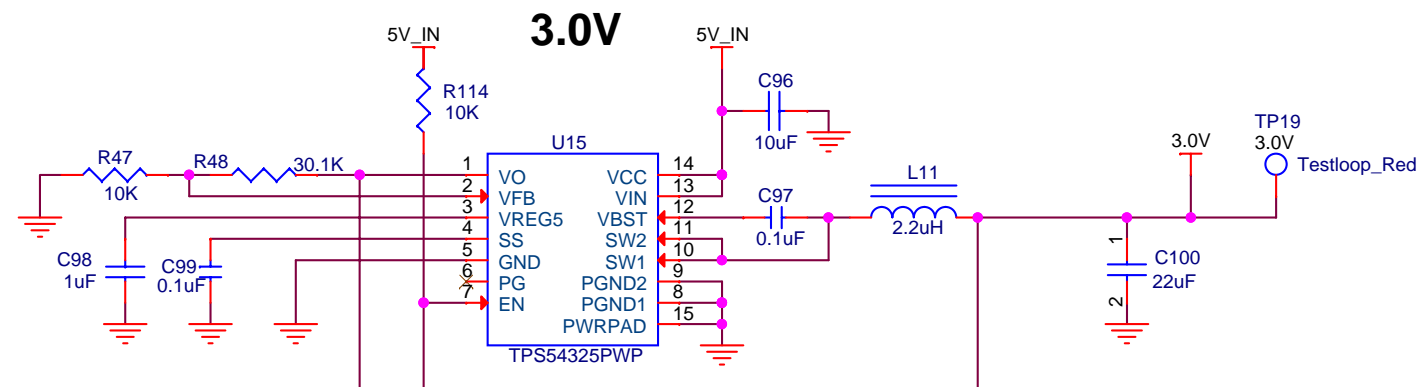
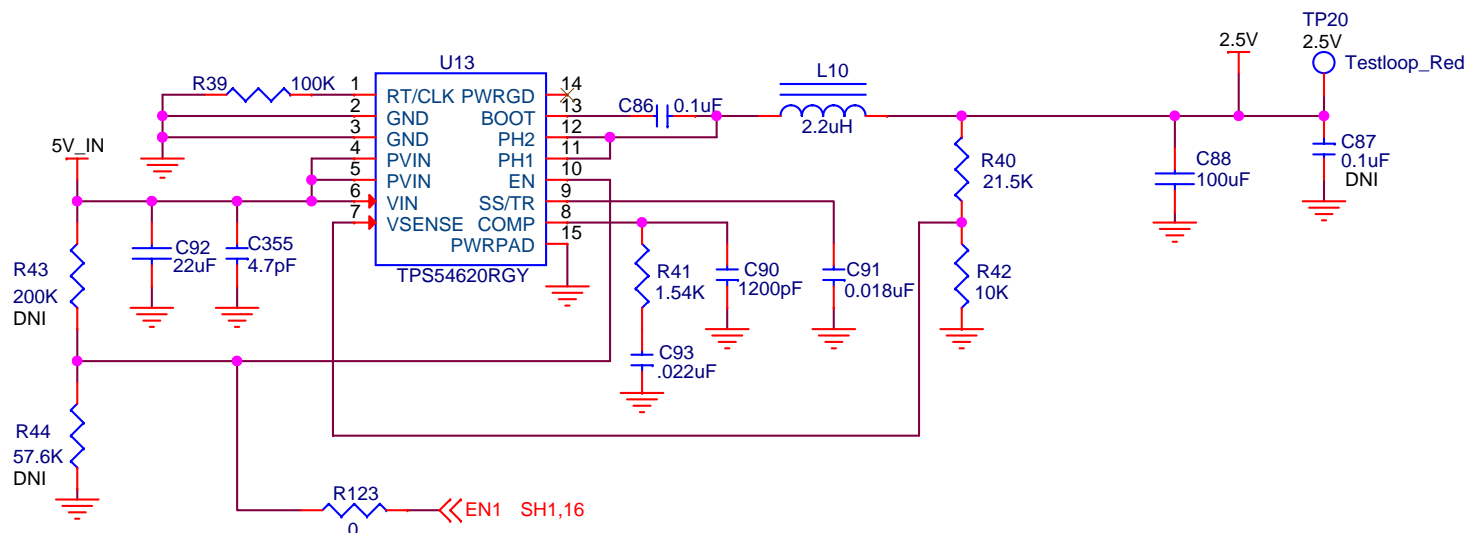
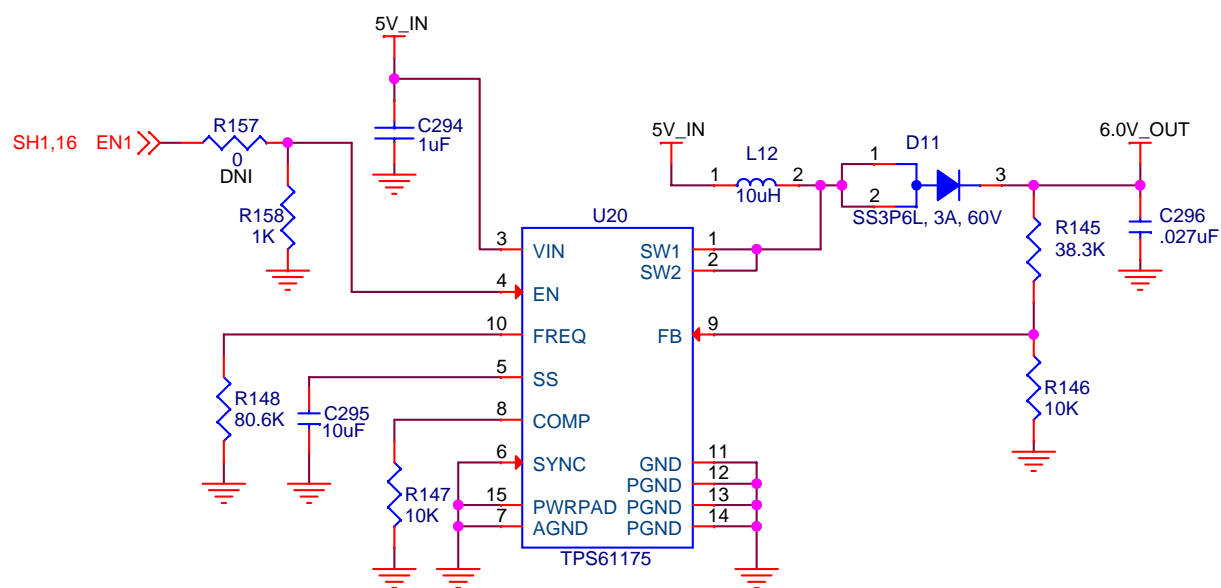

Title		
POWERS 2.5V, 3.0V, 3.3V, 5V		
Size	Document Number	Rev
B	TSW1400	D
Date:	Wednesday, January 04, 2012	Sheet 17 of 21

# FPGA Power

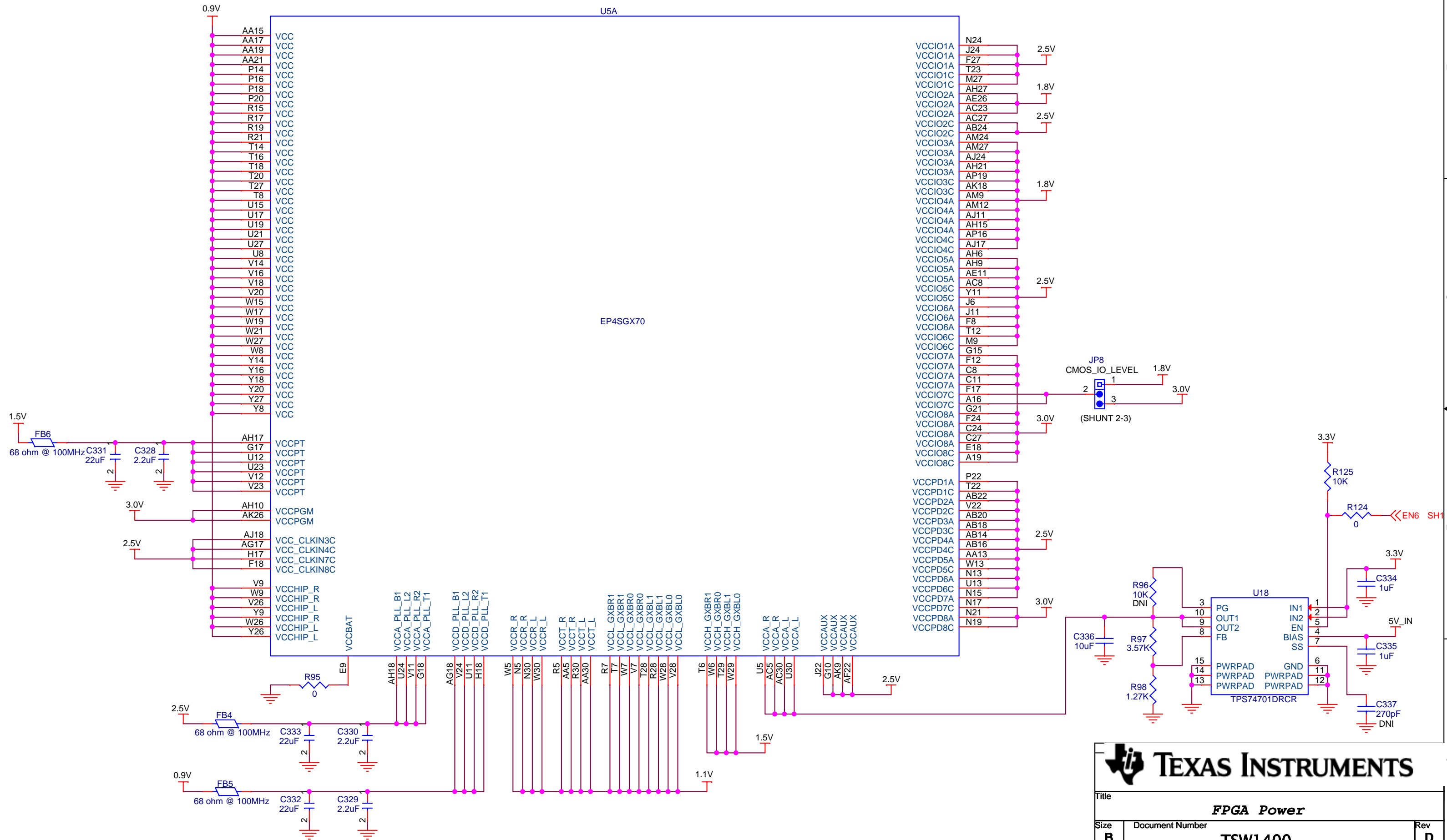

**TEXAS INSTRUMENTS**

Title: **FPGA Power**

Size: **B** Document Number: **TSW1400** Rev: **D**

Date: Wednesday, January 04, 2012 Sheet 18 of 21



# FPGA Ground

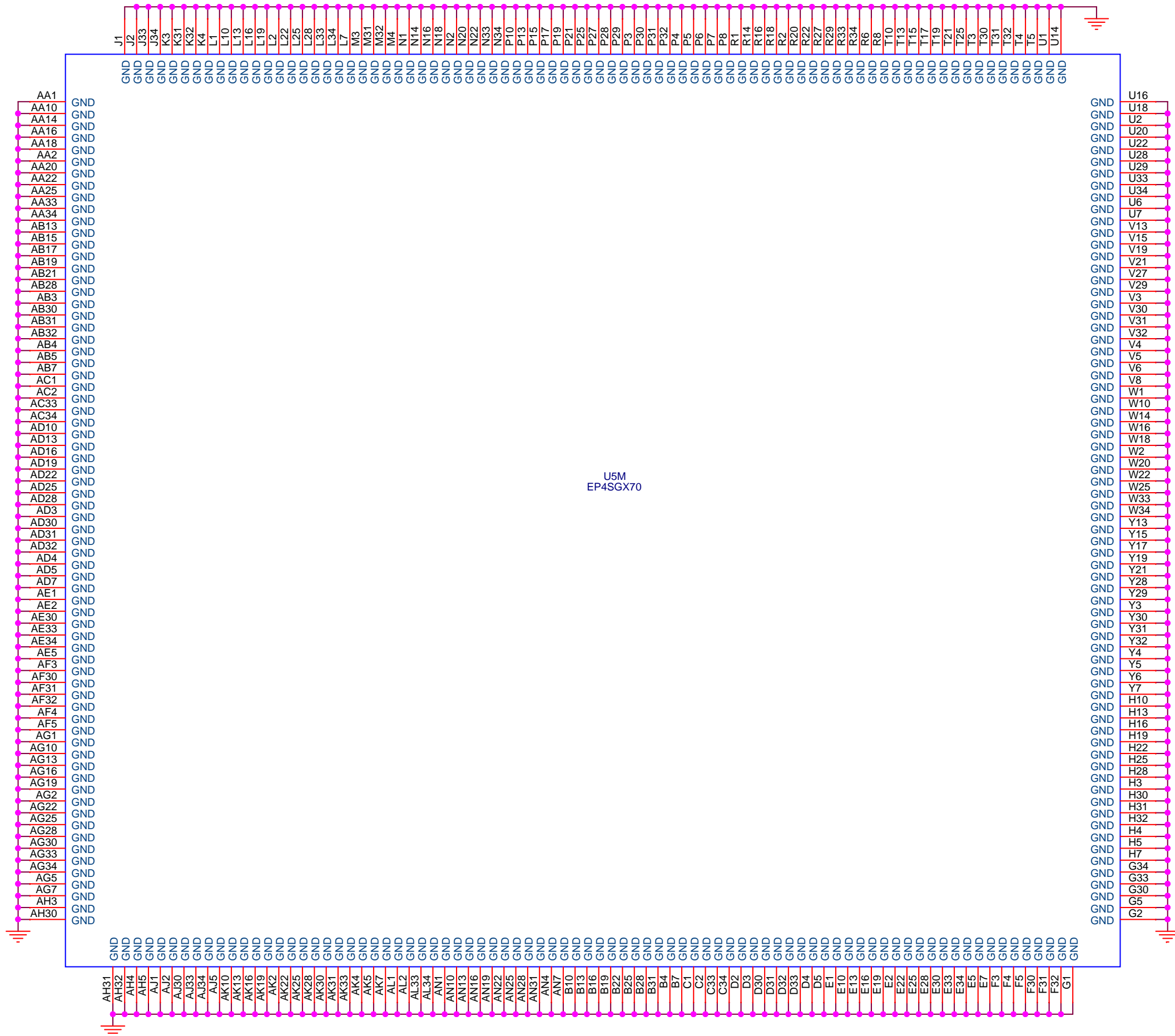

Title		
<b>FPGA Ground</b>		
Size	Document Number	Rev
<b>B</b>	<b>TSW1400</b>	<b>D</b>
Date:	Wednesday, January 04, 2012	Sheet 19 of 21

# FPGA Decoupling

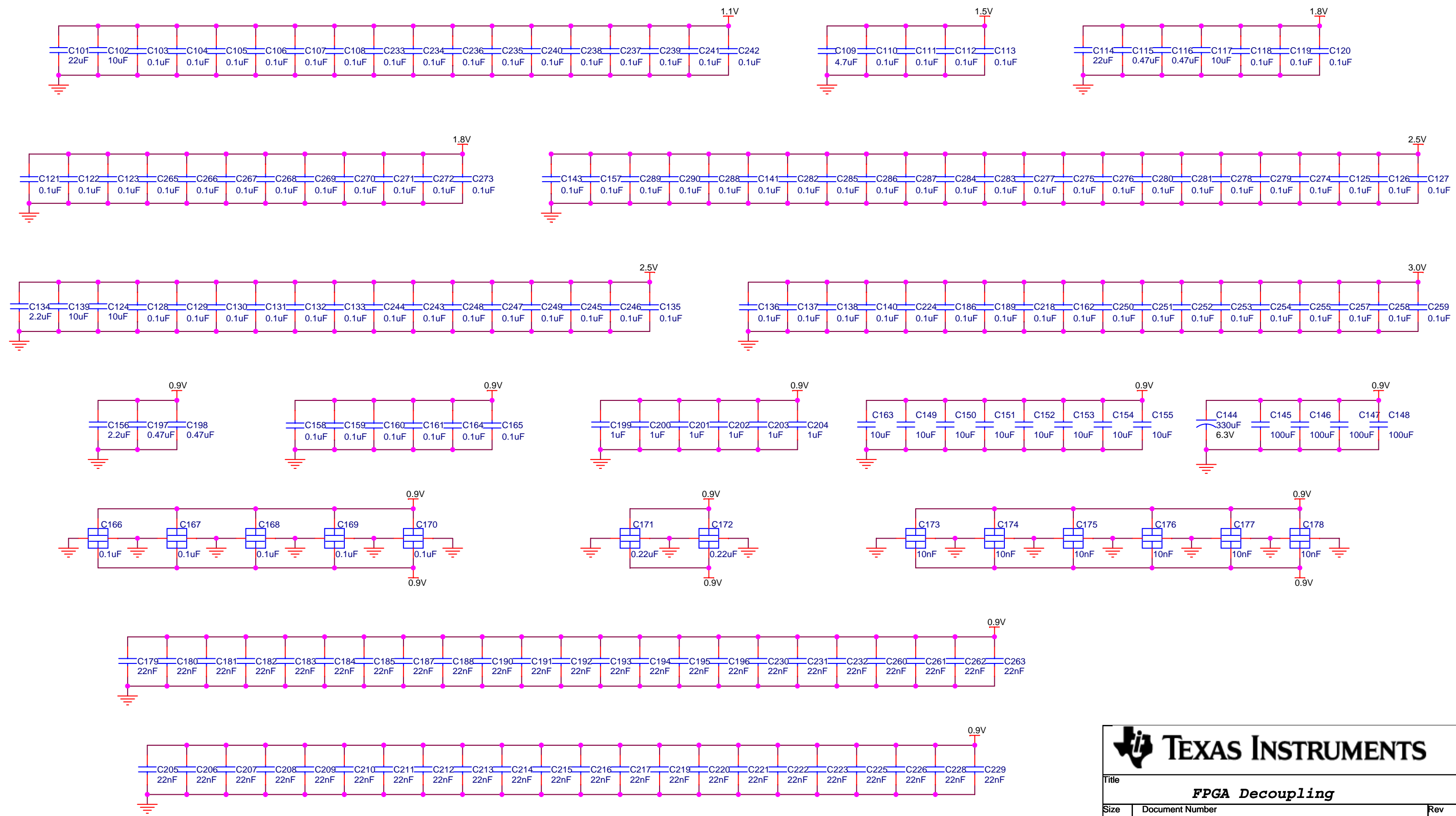

**TEXAS INSTRUMENTS**

Title: **FPGA Decoupling**

Size: <b>B</b>	Document Number: <b>TSW1400</b>	Rev: <b>D</b>
Date: Wednesday, January 04, 2012	Sheet: 20	of 21

# FPGA Configuration

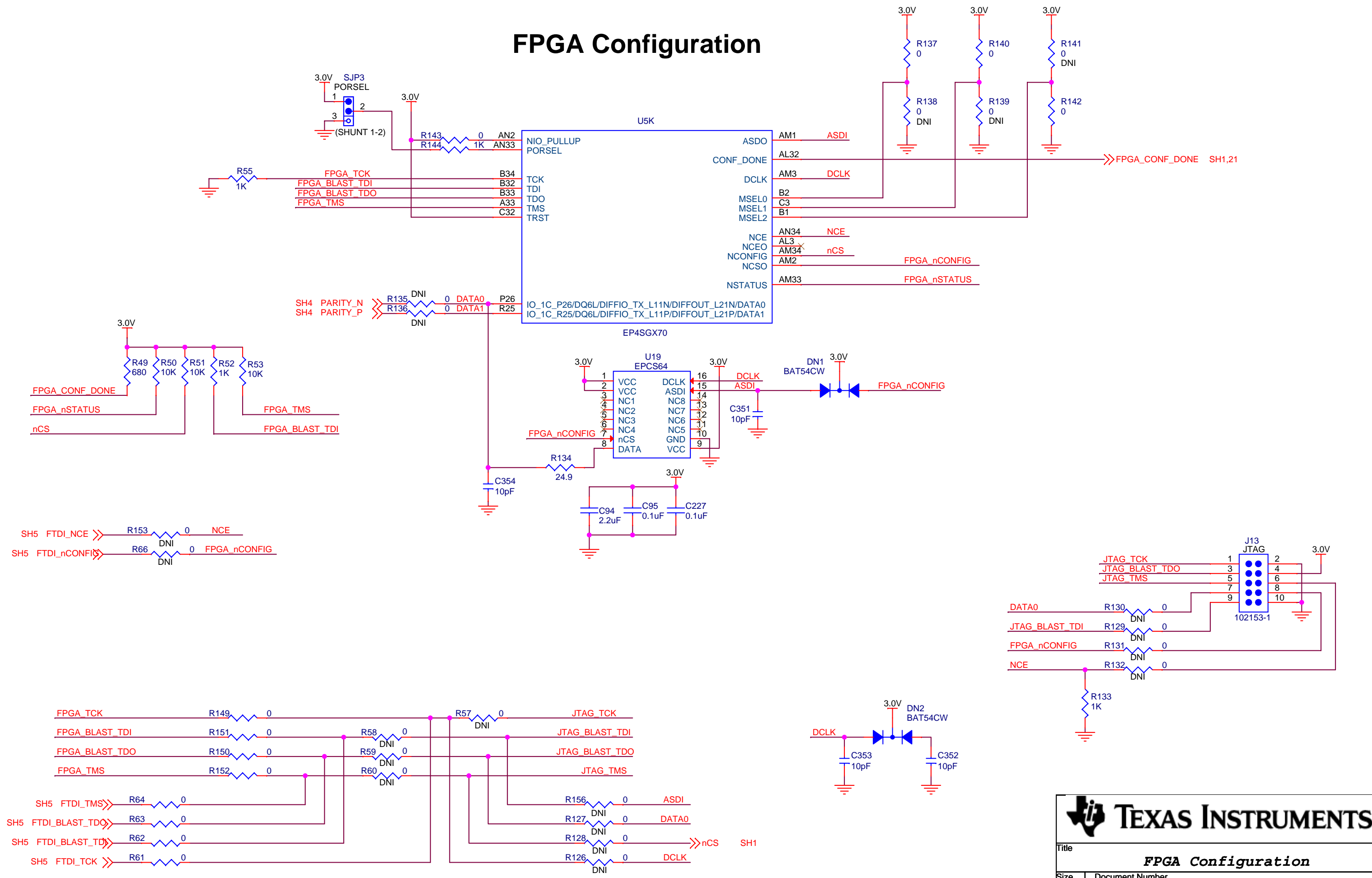

**TEXAS INSTRUMENTS**

Title: **FPGA Configuration**

Size: <b>B</b>	Document Number: <b>TSW1400</b>	Rev: <b>D</b>
Date: Wednesday, January 04, 2012	Sheet: 21 of 21	