

Only the P and M's need to match.

ADC Input	ADC Output	Capacitor	Filter	SH
INA+	DA0+	C5	.1uF	SH8
INA+	DA0-	C6	.1uF	SH8
INA+	DA1+	C7	.1uF	SH8
INA+	DA1-	C8	.1uF	SH8
INA+	DA2+	C9	.1uF	SH8
INA+	DA2-	C10	.1uF	SH8
INA+	DA3+	C11	.1uF	SH8
INA+	DA3-	C12	.1uF	SH8
INA+	DA4+	C13	.1uF	SH8
INA+	DA4-	C15	.1uF	SH8
INA+	DA5+	C16	.1uF	SH8
INA+	DA5-	C18	.1uF	SH8
INA+	DA6+	C19	.1uF	SH10
INA+	DA6-	C21	.1uF	SH10
INA+	DA7+	C22	.1uF	SH10
INA+	DA7-	C23	.1uF	SH10
INB+	DB0+	C25	.1uF	SH8
INB+	DB0-	C26	.1uF	SH8
INB+	DB1+	C27	.1uF	SH8
INB+	DB1-	C28	.1uF	SH8
INB+	DB2+	C29	.1uF	SH8
INB+	DB2-	C30	.1uF	SH8
INB+	DB3+	C31	.1uF	SH8
INB+	DB3-	C32	.1uF	SH8
INB+	DB4+	C33	.1uF	SH10
INB+	DB4-	C34	.1uF	SH10
INB+	DB5+	C35	.1uF	SH10
INB+	DB5-	C36	.1uF	SH10
INB+	DB6+	C37	.1uF	SH10
INB+	DB6-	C38	.1uF	SH10
INB+	DB7+	C39	.1uF	SH10
INB+	DB7-	C40	.1uF	SH10

TEXAS INSTRUMENTS
 12000 TI Boulevard Dallas, Texas 75243

Title: **ANALOG IN**

Size: **B** Document Number: **HSP001** Rev: **A**

Date: Friday, April 07, 2017 Sheet 2 of 14

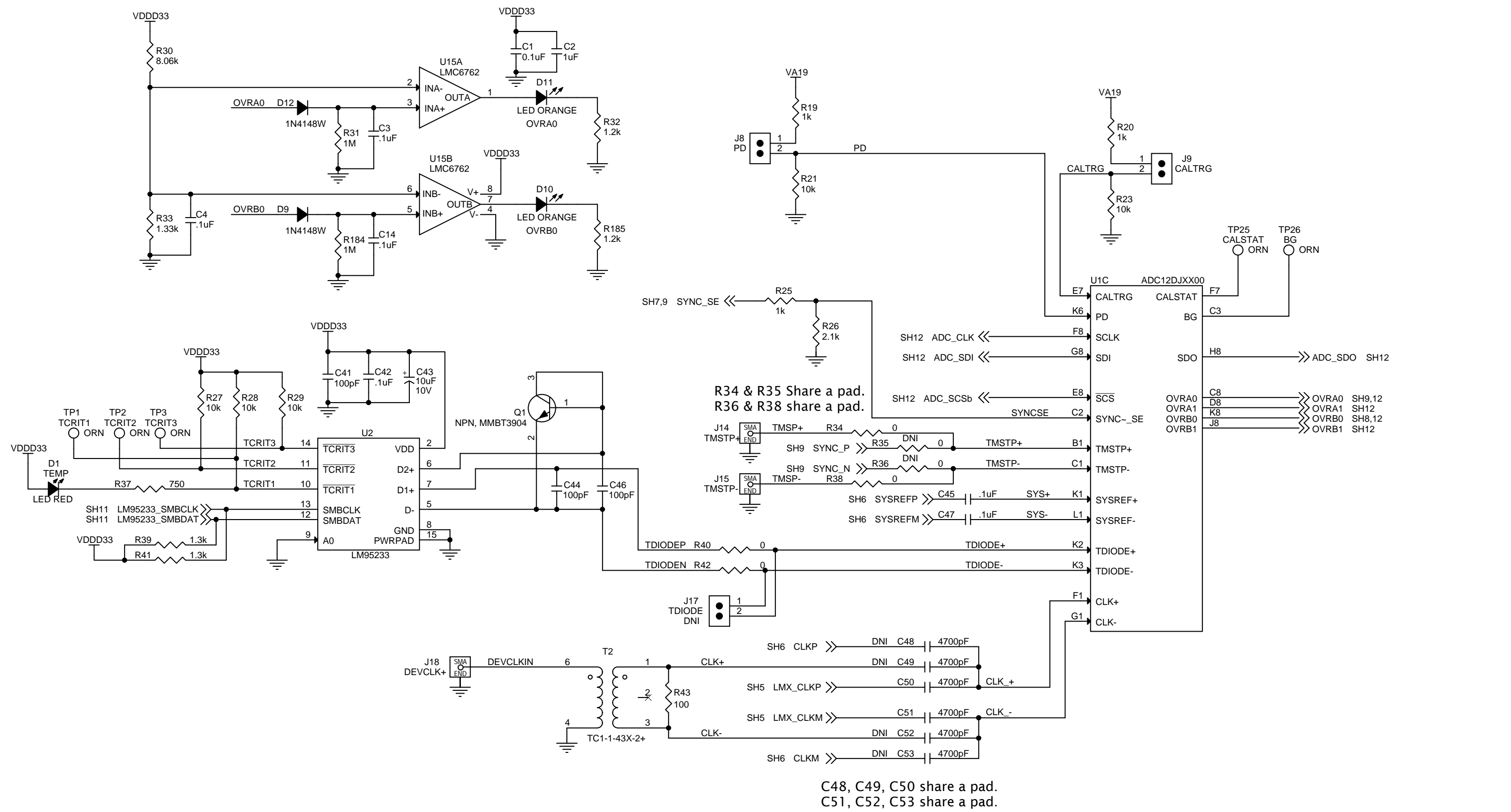

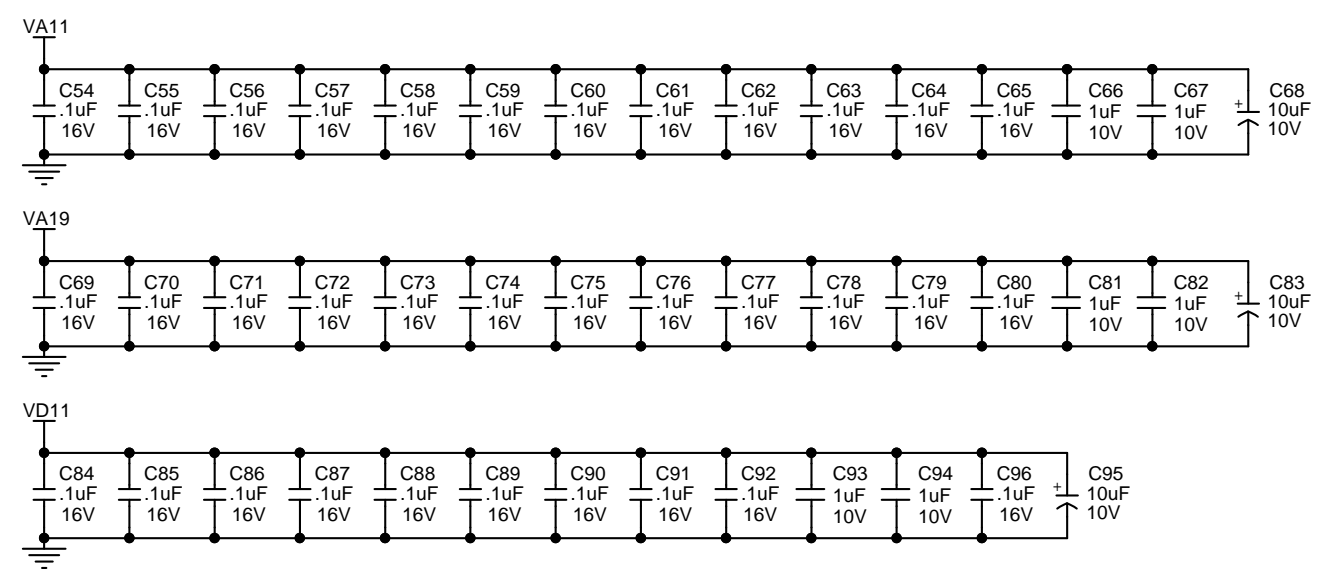
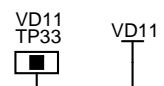
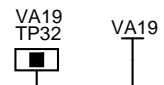
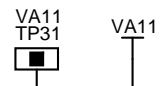
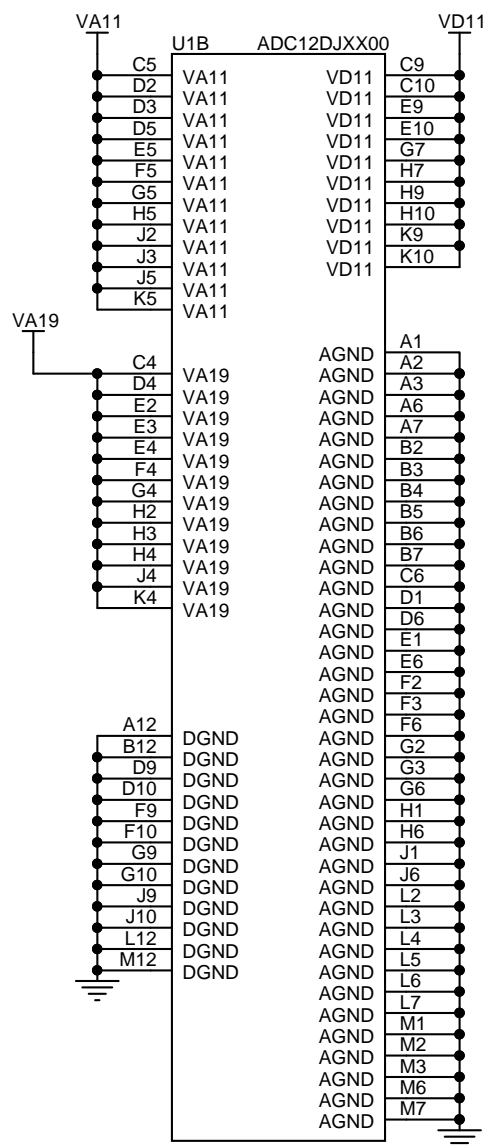

TEXAS INSTRUMENTS

Title		
ADC POWER		
Size	Document Number	Rev
B	HSP001	A
Date:	Friday, March 31, 2017	Sheet 4 of 14

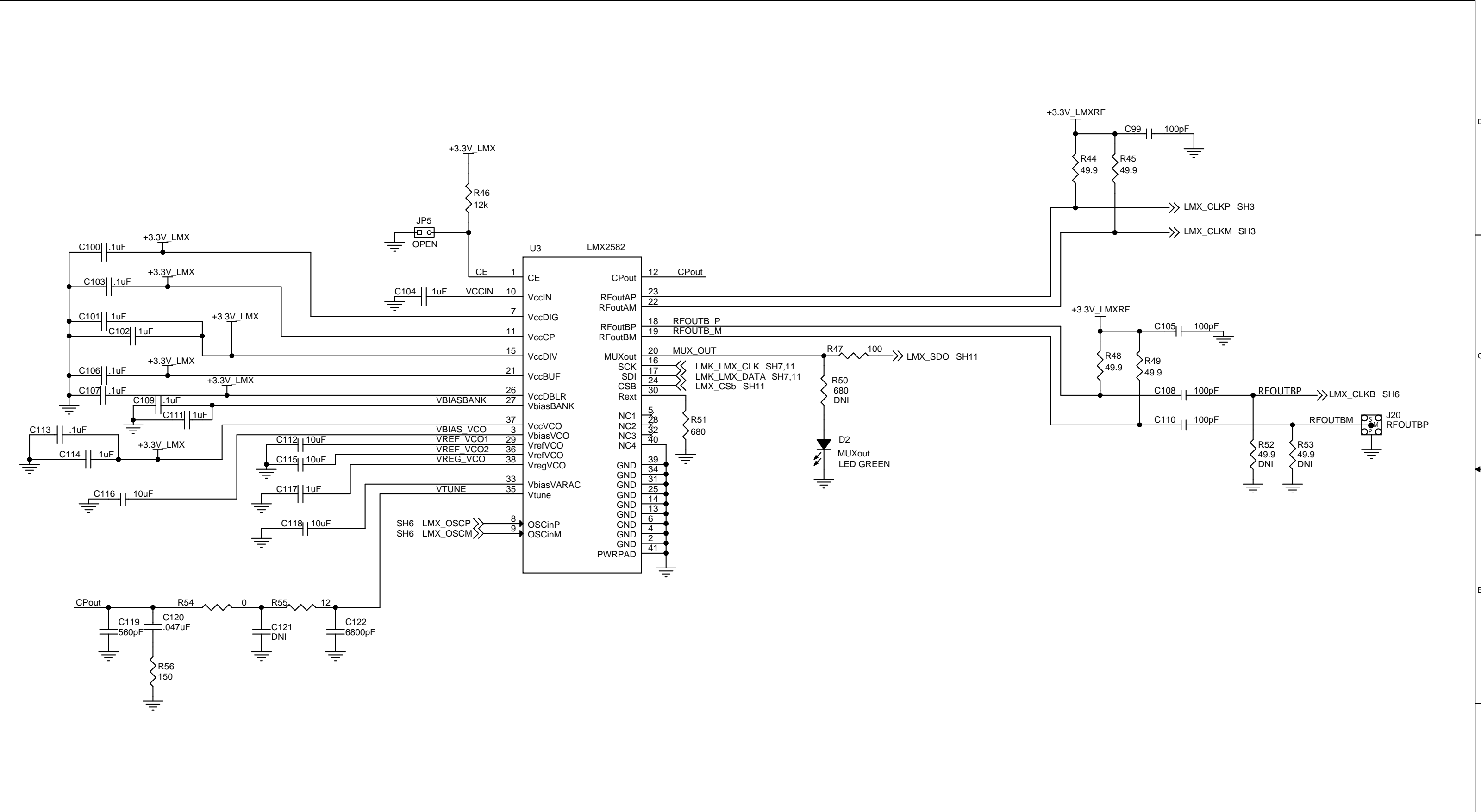

TEXAS INSTRUMENTS

12500 TI Boulevard, Dallas, Texas 75243

LMX

Size B	Document Number HSP001	Rev A
------------------	----------------------------------	-----------------

Date: Friday, March 31, 2017 Sheet 5 of 14

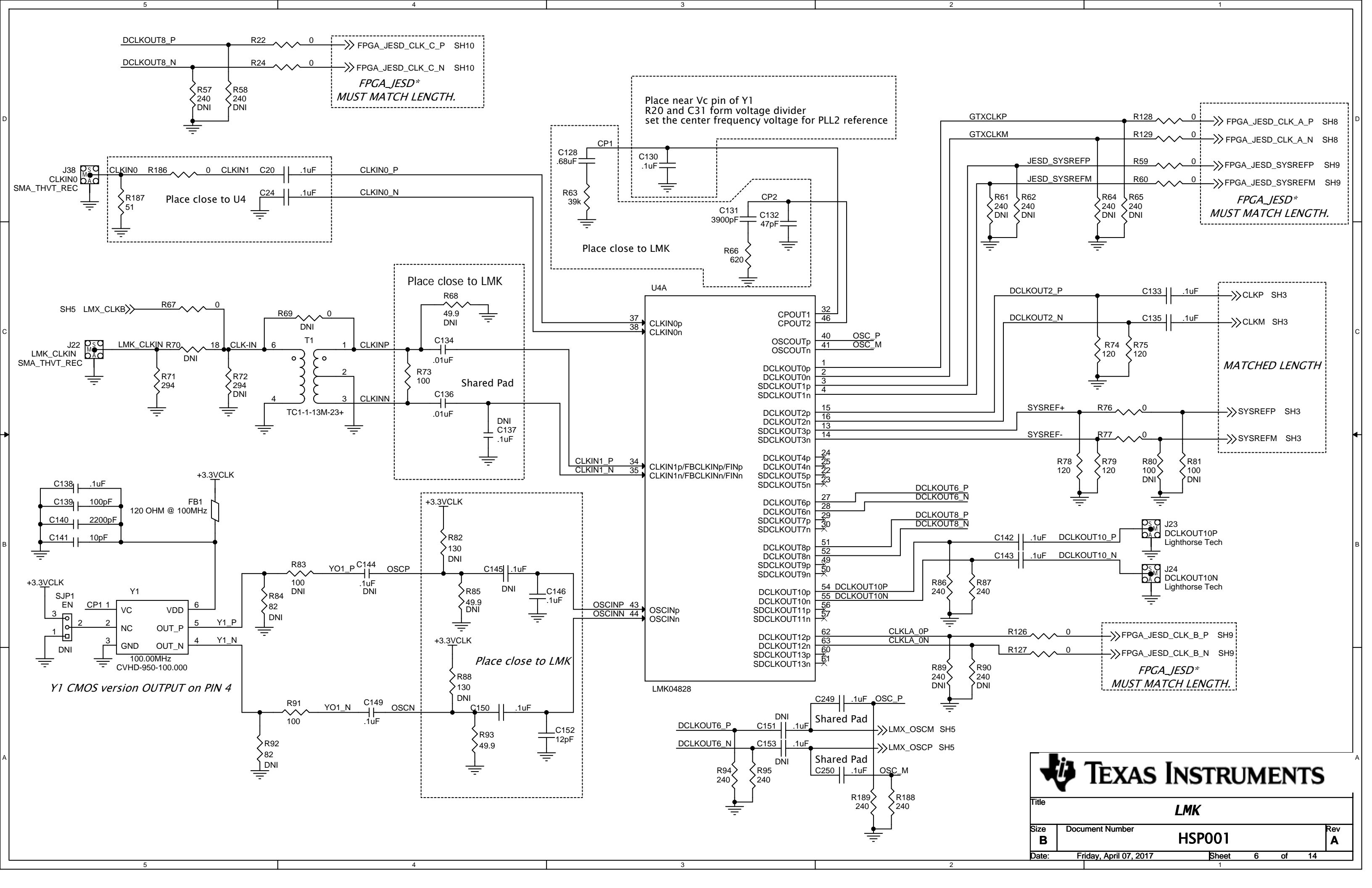

FPGA_JESD*
MUST MATCH LENGTH.

Place near Vc pin of Y1
R20 and C31 form voltage divider
set the center frequency voltage for PLL2 reference

Place close to U4

Place close to LMK

Place close to LMK

Shared Pad

Place close to LMK

FPGA_JESD*
MUST MATCH LENGTH.

MATCHED LENGTH

FPGA_JESD*
MUST MATCH LENGTH.

Y1 CMOS version OUTPUT on PIN 4

TEXAS INSTRUMENTS

Title: **LMK**

Size: **B** | Document Number: **HSP001** | Rev: **A**

Date: Friday, April 07, 2017 | Sheet: 6 of 14

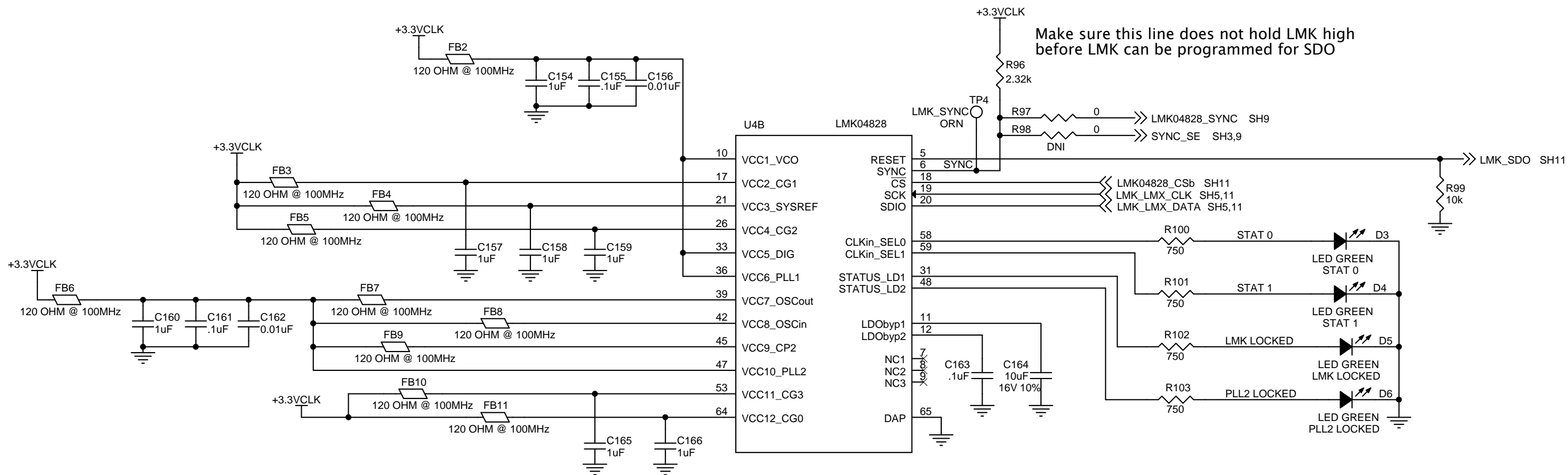

TEXAS INSTRUMENTS

Title: **LMK POWER**

Size B	Document Number	HSP001	Rev A
Date: Friday, March 31, 2017	Sheet 7	of 14	

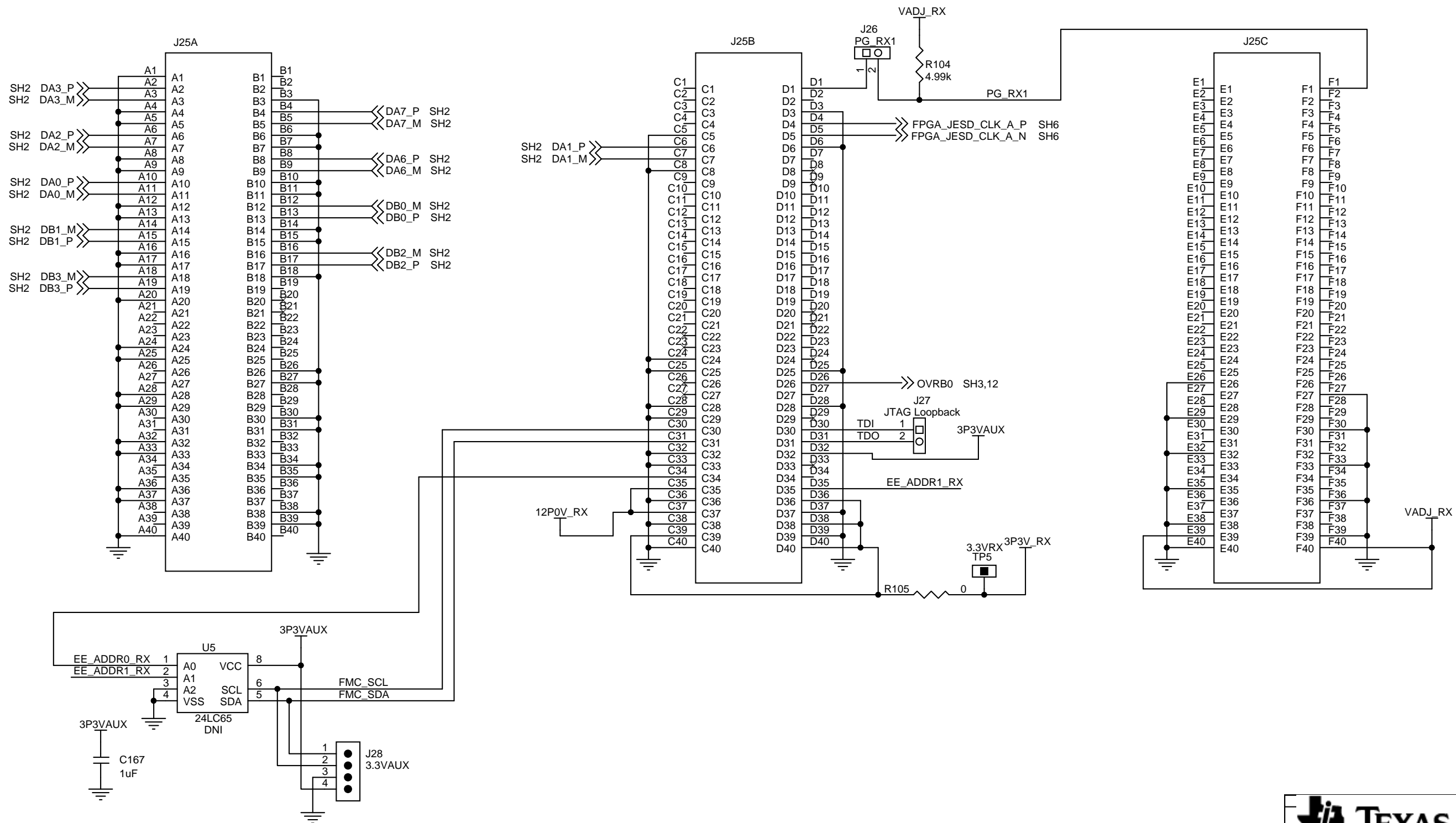

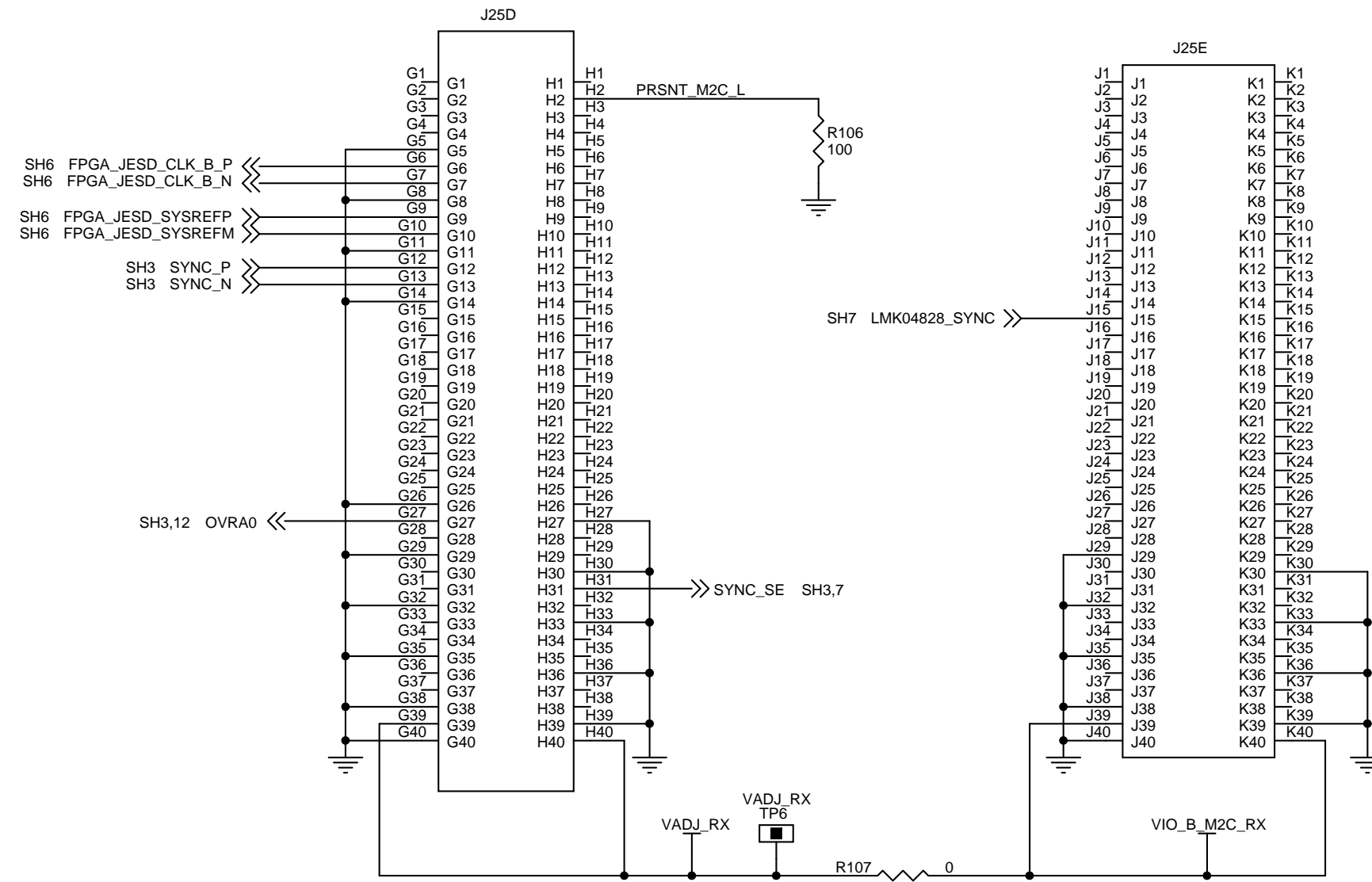

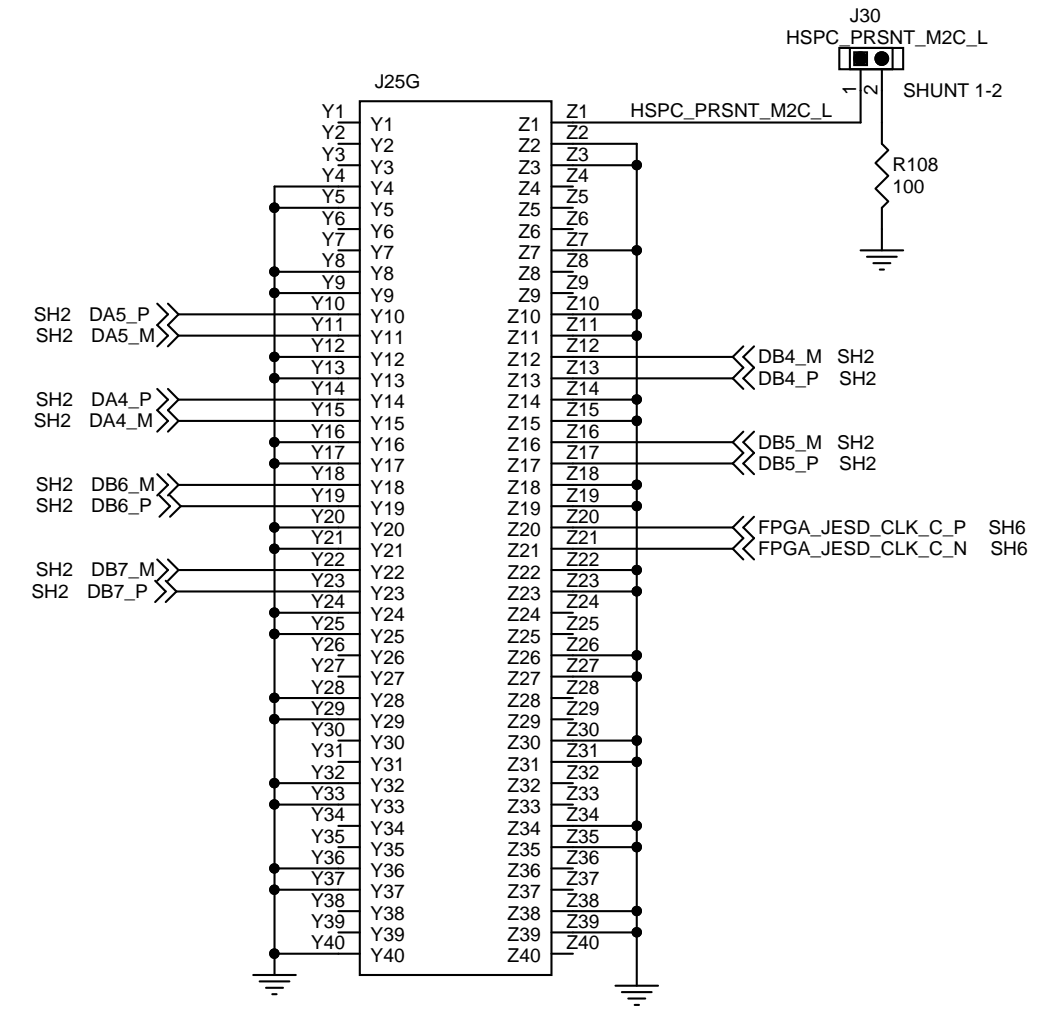
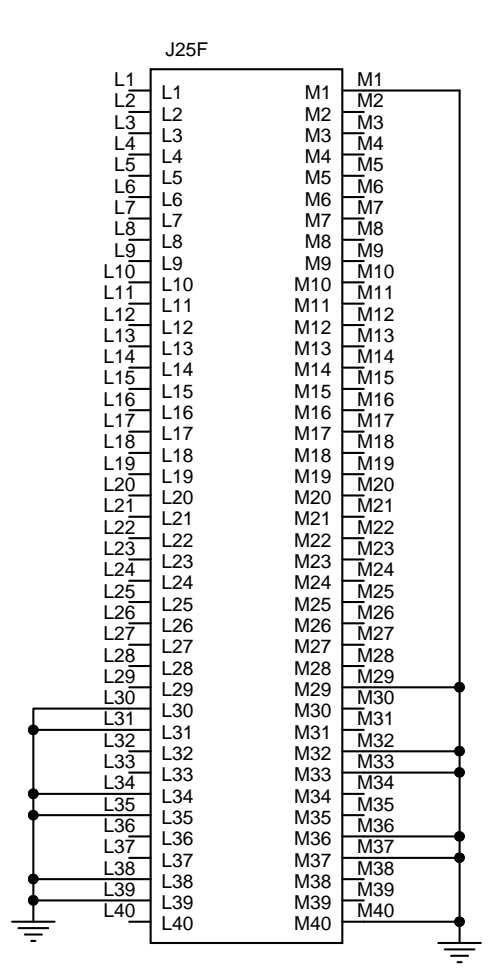

TEXAS INSTRUMENTS

Title: **OUTPUT - FMC CONNECTOR**

Size: B	Document Number: HSP001	Rev: A
Date: Thursday, February 16, 2017	Sheet: 10	of 14

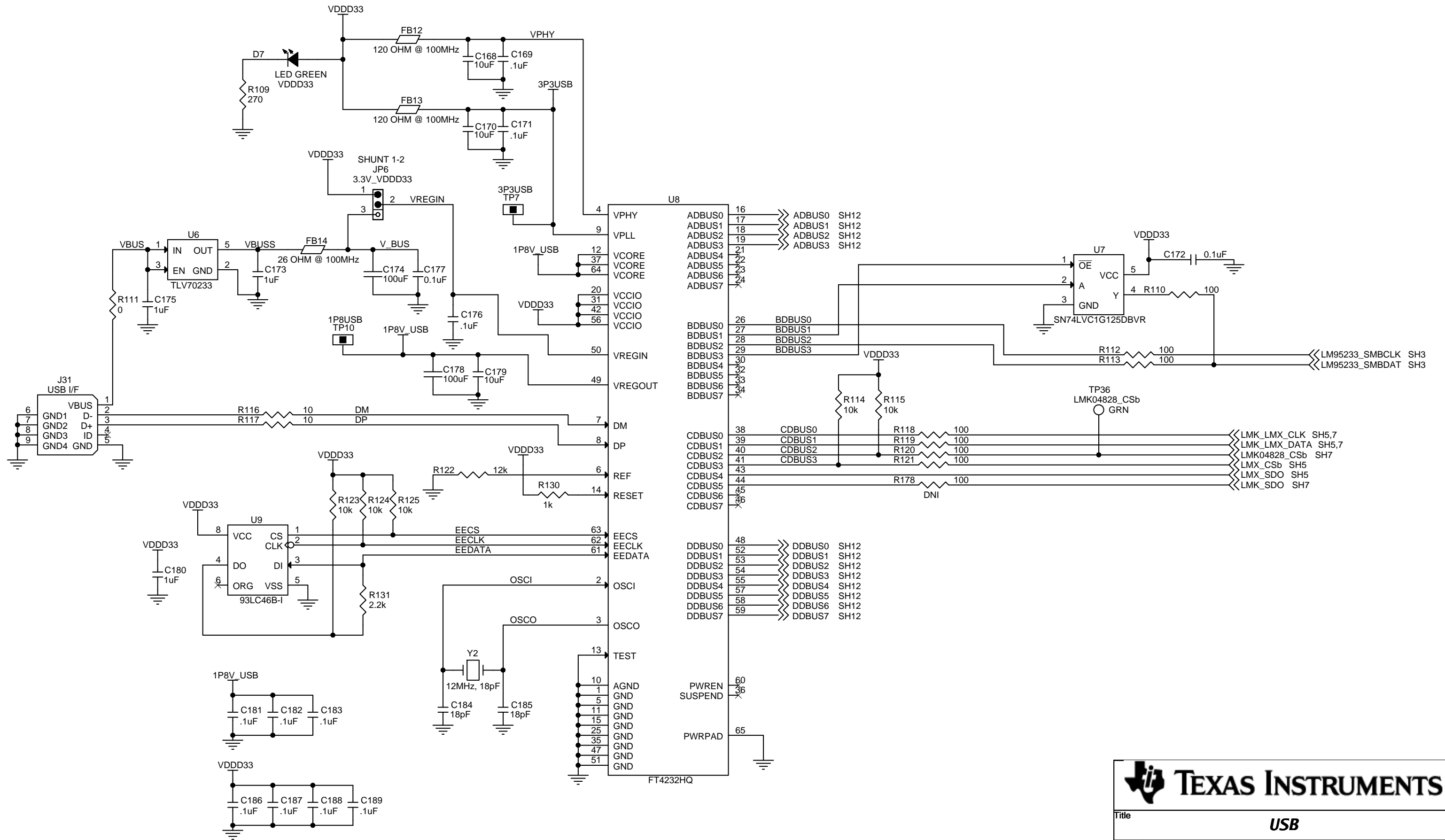

TEXAS INSTRUMENTS

Title: **USB**

Size B	Document Number HSP001	Rev A
Date: Friday, March 31, 2017	Sheet 11 of 14	

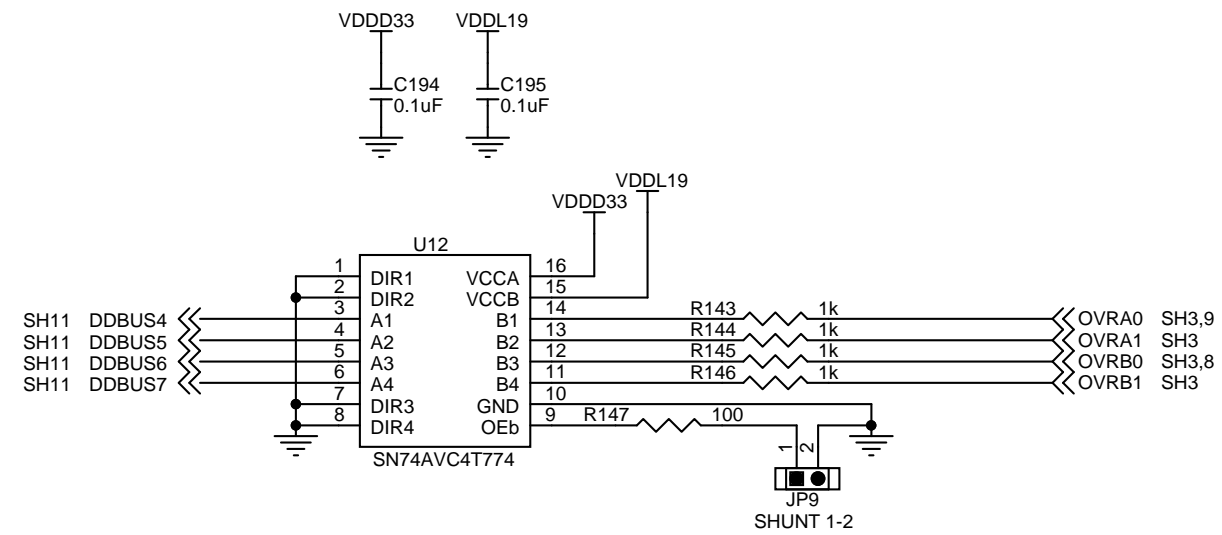
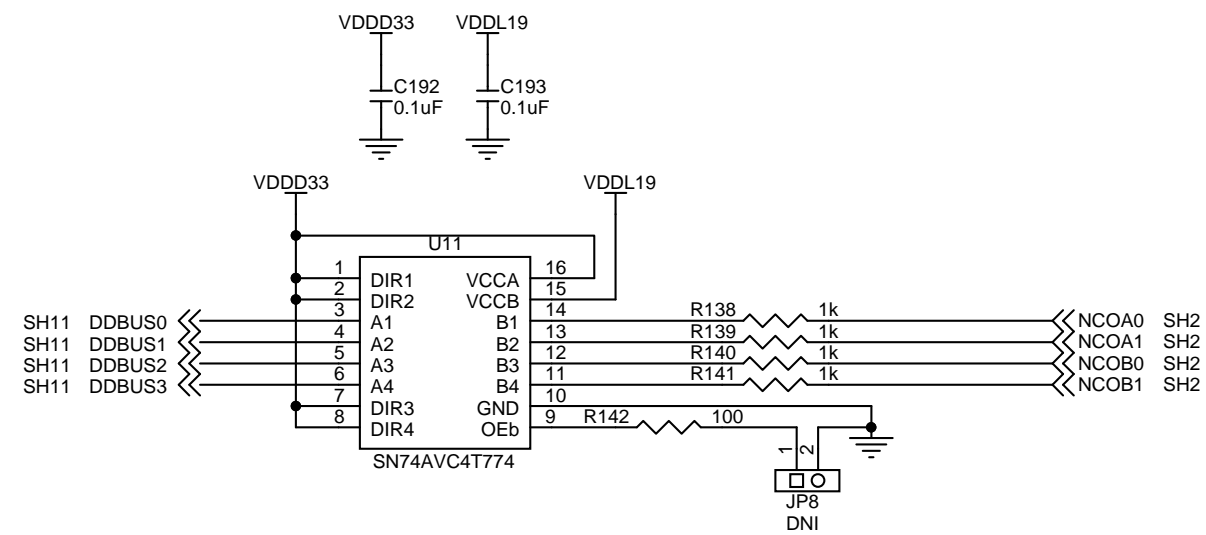
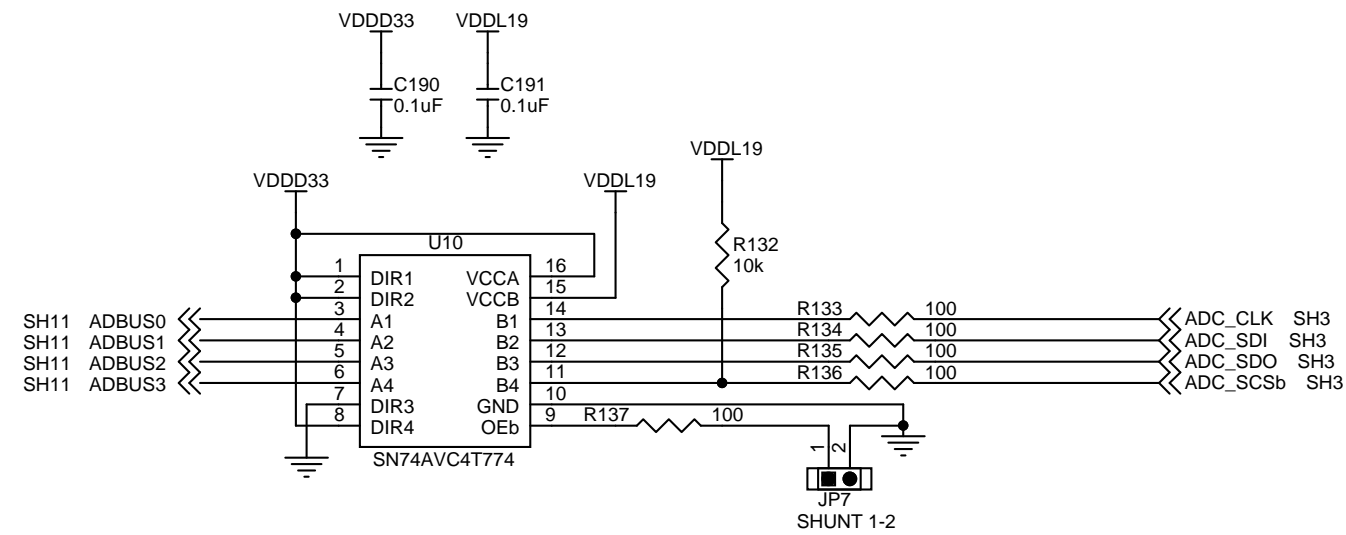

Title		
LEVEL SHIFTERS		
Size	Document Number	Rev
B	HSP001	A
Date:	Monday, January 16, 2017	Sheet 12 of 14

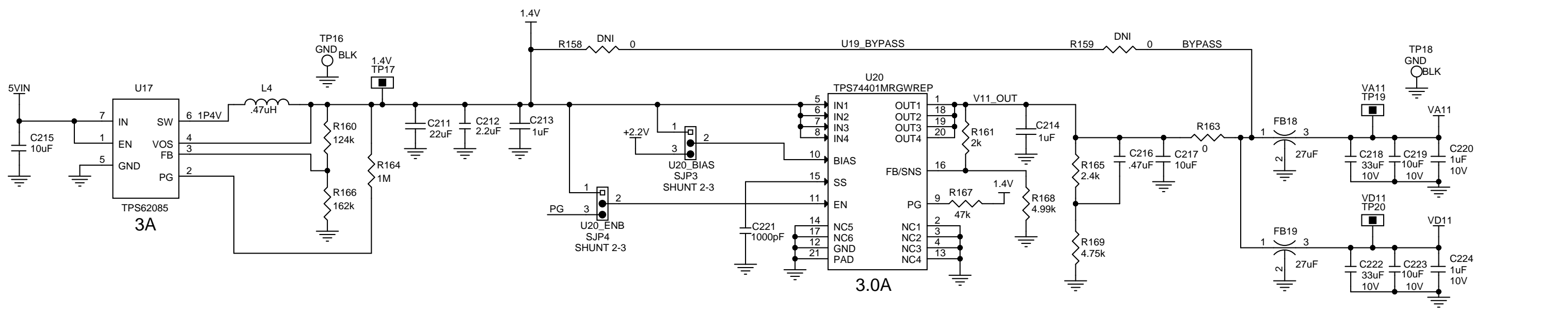
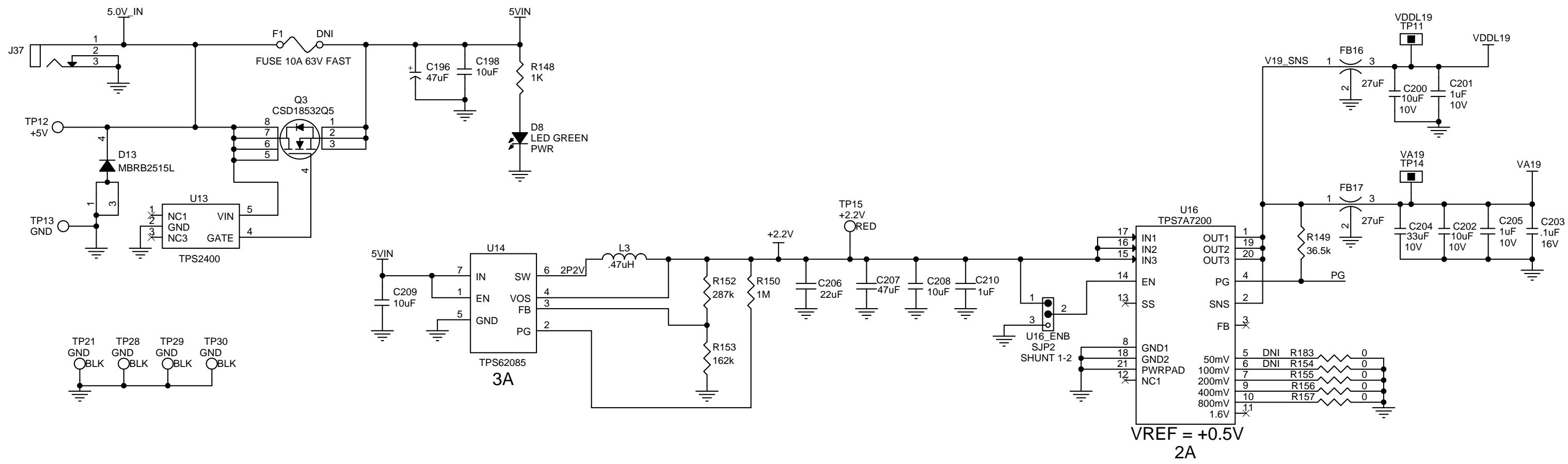

TEXAS INSTRUMENTS

Title: **ADC POWER SUPPLIES**

Size: B	Document Number: HSP001	Rev: A
Date: Friday, March 31, 2017	Sheet: 13	of 14

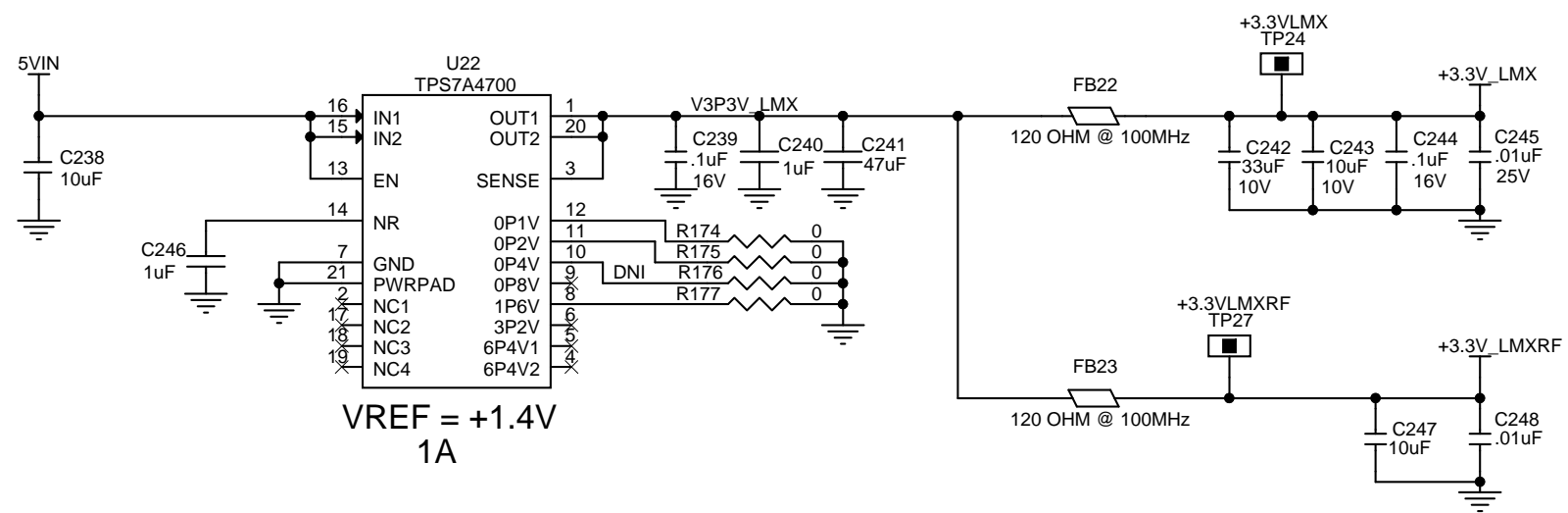
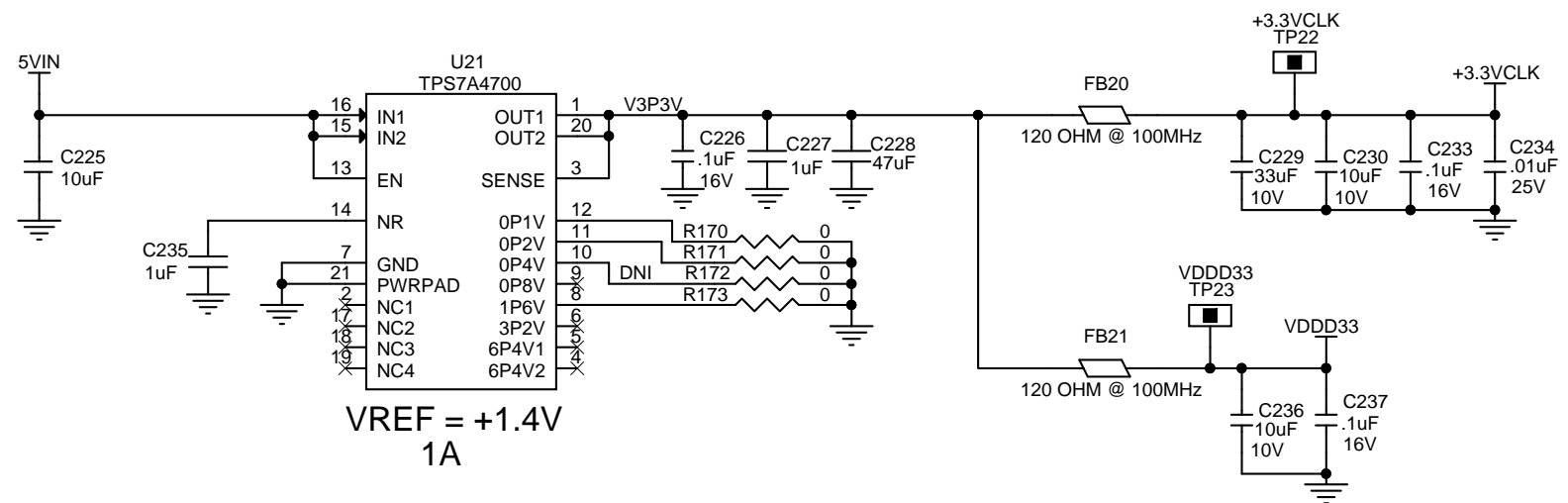

MECHANICAL PARTS

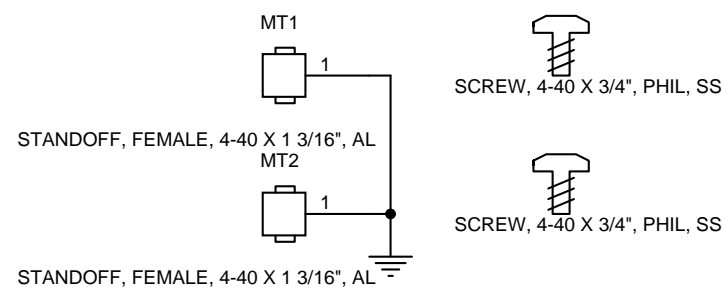
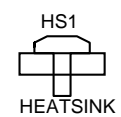
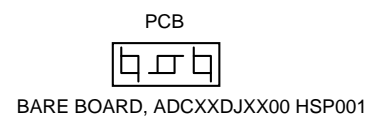

TEXAS INSTRUMENTS

Title: **POWER SUPPLIES**

Size: **B** Document Number: **HSP001** Rev: **A**

Date: Friday, May 12, 2017 Sheet 14 of 14