

DAC7568EVM Waveform measurement(1/2)

Overview

Performed DA conversion using DAC7568. Although the intended voltage is obtained, if the update cycle is made faster, the output becomes 0.

Evaluation target

DAC7568EVM

000_50usCycle CH1#SCLK CH2#DIN CH3#OUT-C.jpg

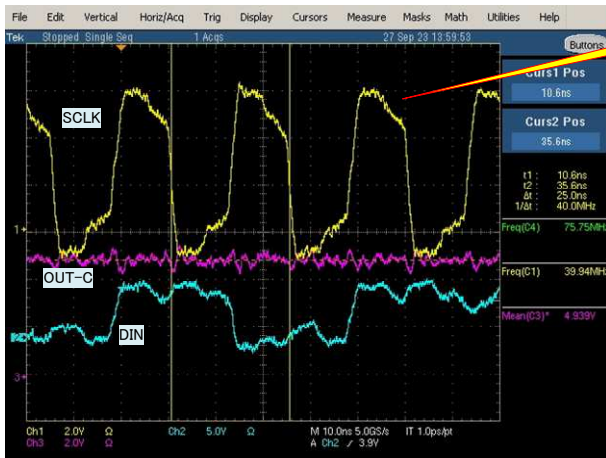

Clock: 40MHz
Update cycle: 25us or 50us

Update cycle: 25us or 50us

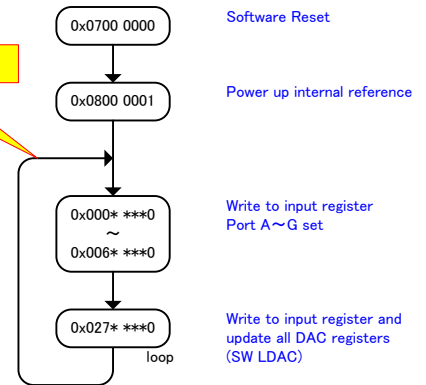

001_25usCycle-50usCycle CH1#SCLK CH3#OUT-C.jpg

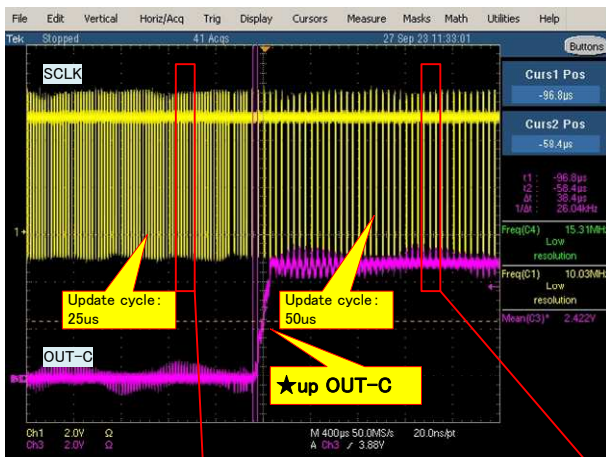

002_50usCycle-25usCycle CH1#SCLK CH3#OUT-C.jpg



Update cycle 25us

Update cycle 50us

003_25usCycle CH1#SCLK CH2#SYNC CH3#OUT-C.jpg



Update cycle: 25us

004_50usCycle CH1#SCLK CH2#SYNC CH3#OUT-C.jpg



Update cycle: 50us

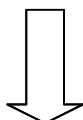

Same result thereafter

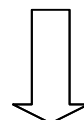

DAC7568EVM Waveform measurement(1/2)

Update cycle 25us

Update cycle 50us

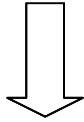

Same result thereafter

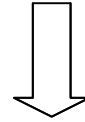

005_25usCycle CH1#SCLK CH2#SYNC CH3#OUT-C.jpg

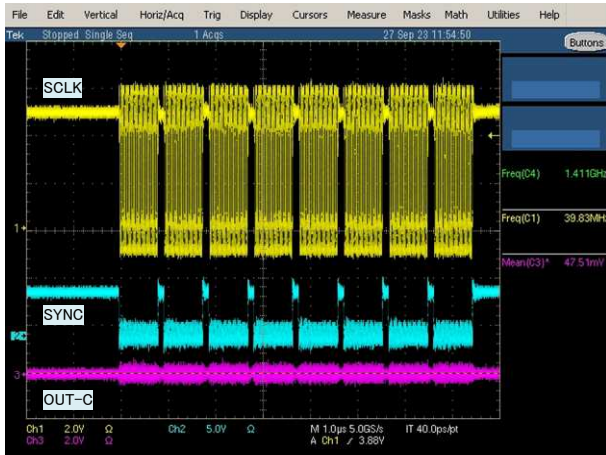

006_50usCycle CH1#SCLK CH2#SYNC CH3#OUT-C.jpg

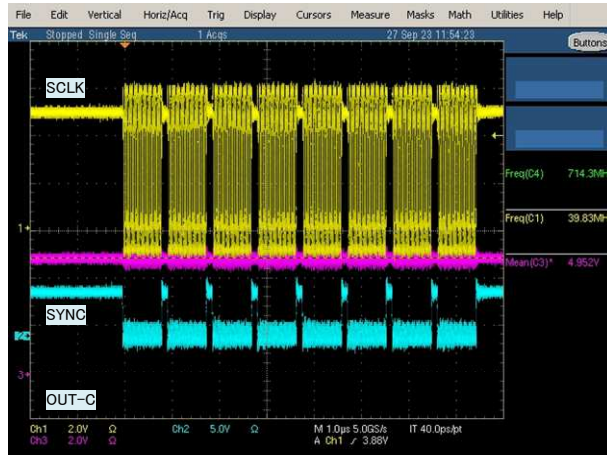

007_25usCycle CH1#SCLK CH2#DIN CH3#OUT-C.jpg



- out A
0x000F FF00
- out B
0x0018 8000
- out C
0x002F FF00
- out D
0x0038 8000
- out E
0x0040 0000
- out F
0x005F FF00
- out G
0x0060 0000
- out H
0x0270 0000

008_50usCycle CH1#SCLK CH2#DIN CH3#OUT-C.jpg



- out A
0x000F FF00
- out B
0x0018 8000
- out C
0x002F FF00
- out D
0x0038 8000
- out E
0x0040 0000
- out F
0x005F FF00
- out G
0x0060 0000
- out H
0x0270 0000