

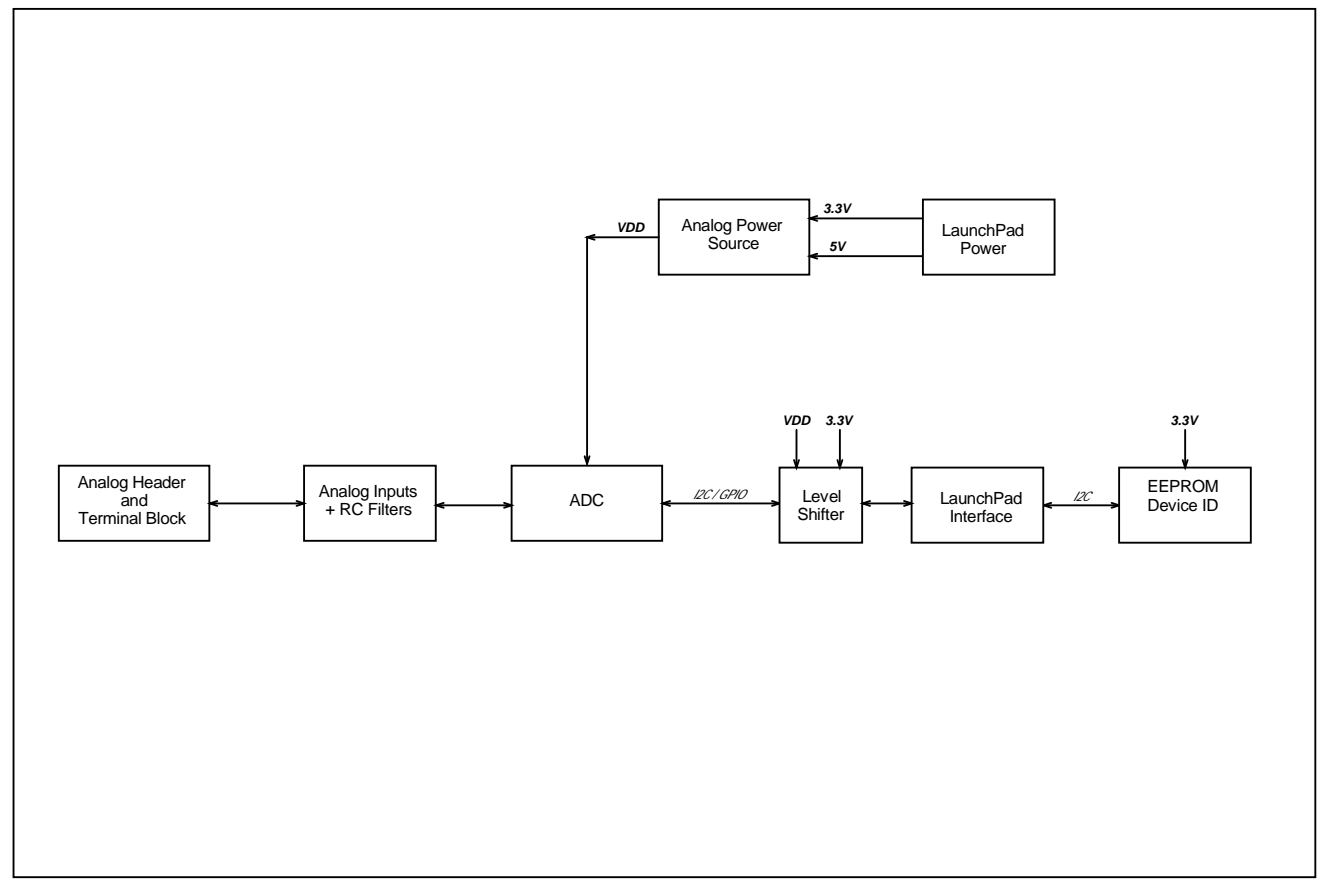

Revision History

Rev	ECN #	Approved Date	Approved by	Notes
N/A	N/A	N/A	N/A	N/A

Schematic Block Diagram



Texas Instruments and/or its licensors do not warrant the accuracy or completeness of this specification or any information contained therein. Texas Instruments and/or its licensors do not warrant that this design will meet the specifications, will be suitable for your application or fit for any particular purpose, or will operate in an implementation. Texas Instruments and/or its licensors do not warrant that the design is production worthy. You should completely validate and test your design implementation to confirm the system functionality for your application.

Orderable: ADS1118EVM	Designed for: Public Release	Mod. Date: 7/6/2020	 http://www.ti.com © Texas Instruments 2020
TID #: N/A	Project Title: ADS1x18EVM		
Number: DC031	Rev: A	Sheet Title: Block Diagram	
SVN Rev: Not in version control	Assembly Variant: 001	Sheet: 1 of 3	
Drawn By: Robert Benjamin	File: DC031_CoverSheet.SchDoc	Size: B	
Engineer: Robert Benjamin	Contact: http://www.ti.com/support		

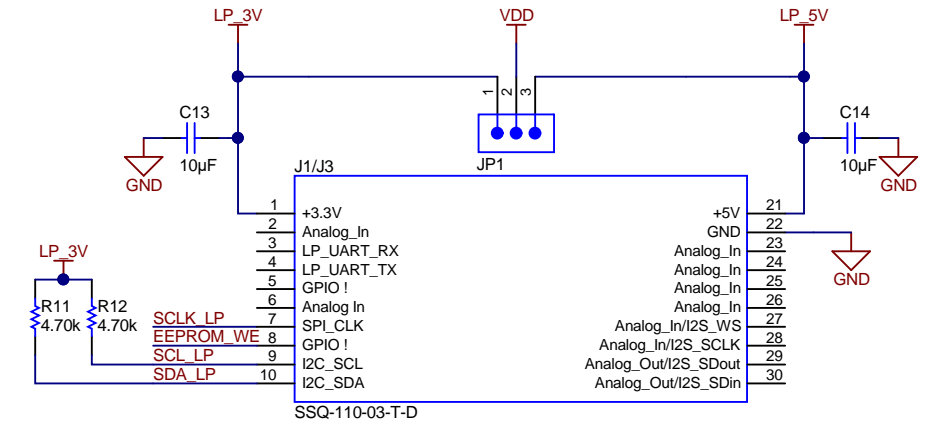
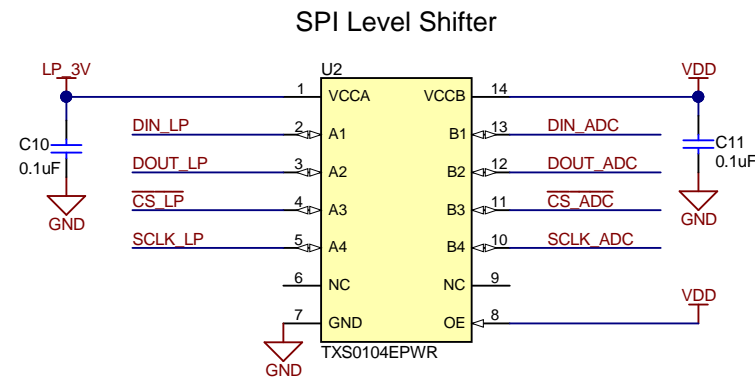
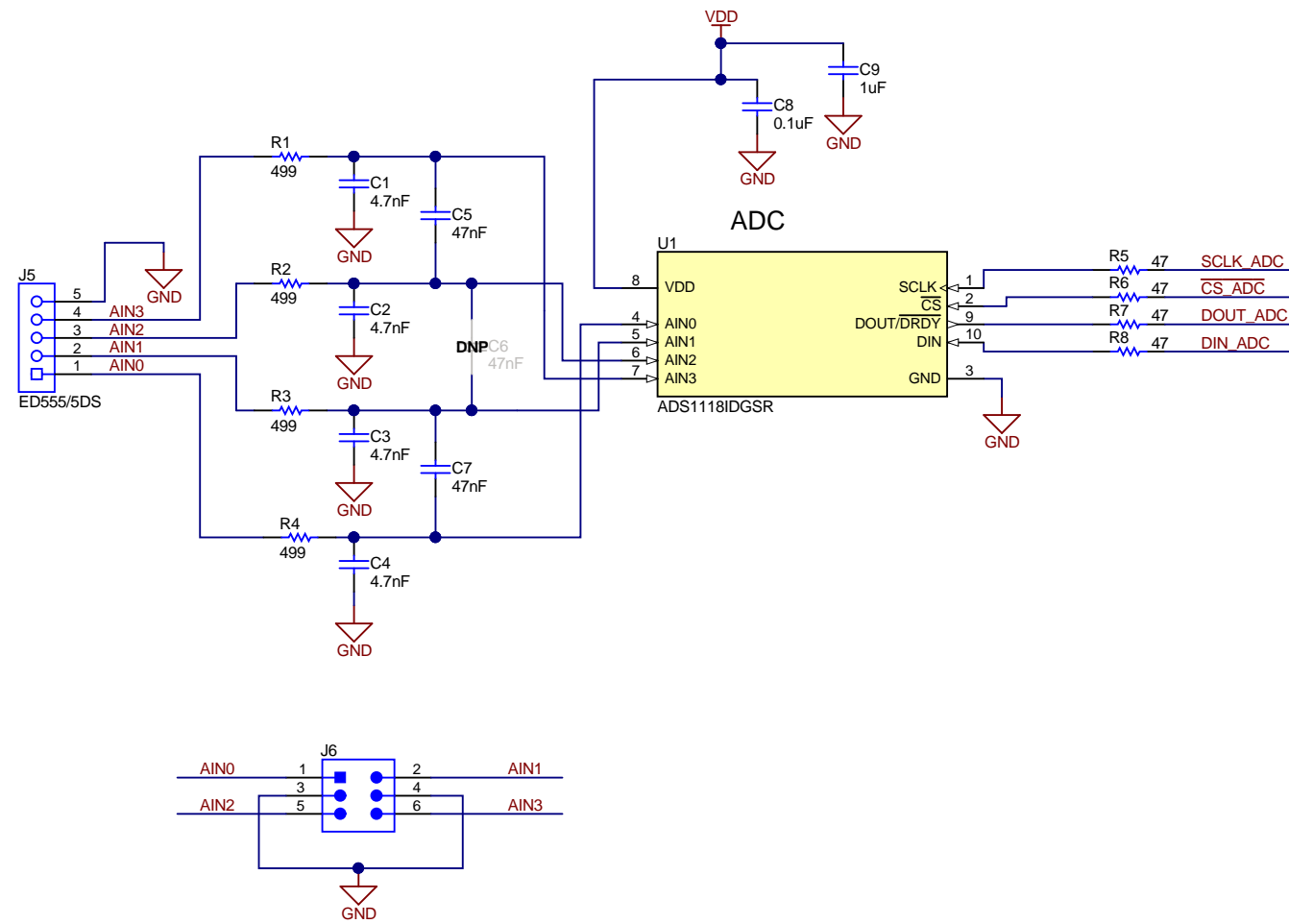

EEPROM Memory

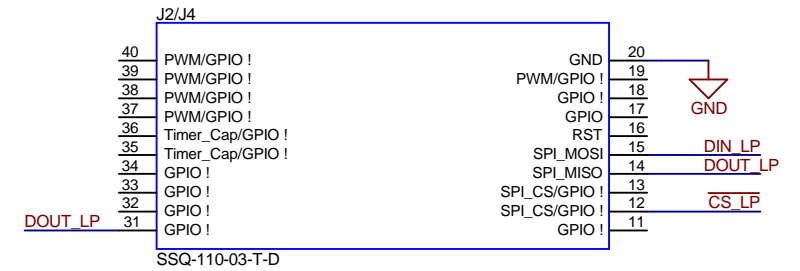
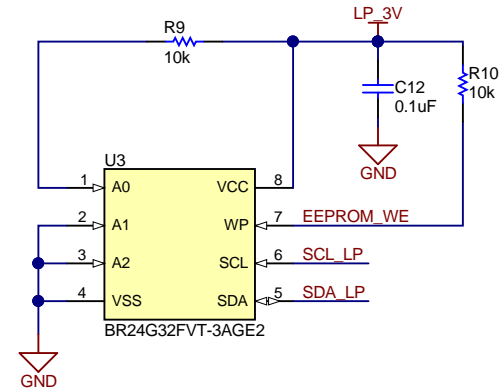

Launchpad Connectors

Texas Instruments and/or its licensors do not warrant the accuracy or completeness of this specification or any information contained therein. Texas Instruments and/or its licensors do not warrant that this design will meet the specifications, will be suitable for your application or fit for any particular purpose, or will operate in an implementation. Texas Instruments and/or its licensors do not warrant that the design is production worthy. You should completely validate and test your design implementation to confirm the system functionality for your application.

Orderable: ADS1118EVM	Designed for: Public Release	Mod. Date: 7/9/2020
TID #: N/A	Project Title: ADS1x18EVM	
Number: DC031	Rev: A	Sheet Title: ADC and Power Supply
SVN Rev: Not in version control	Assembly Variant: 001	Sheet: 2 of 3
Drawn By: Benjamin/Mendez	File: DC031_schematic.SchDoc	Size: B
Engineer: Robert Benjamin	Contact: http://www.ti.com/support	



© Texas Instruments 2020

A



PCB Number: DC031
PCB Rev: A

PCB LOGO PCB LOGO PCB LOGO

PCB Assembly

DC081

B

LBL1
PCB Label

Variant/Label Table	
Variant	Label Text
001	ADS1118EVM
002	ADS1018EVM

ZZ1
Label Assembly Note
This Assembly Note is for PCB labels only

ZZ2
Assembly Note
These assemblies are ESD sensitive, ESD precautions shall be observed.

ZZ3
Assembly Note
These assemblies must be clean and free from flux and all contaminants. Use of no clean flux is not acceptable.

ZZ4
Assembly Note
These assemblies must comply with workmanship standards IPC-A-610 Class 2, unless otherwise specified.

C

D