



Reset Circuit with Manual Reset

Description

The EM6325 is an ultra-low current reset circuit available in a large variety of configurations and very small packages for maximum flexibility in all end-applications up to 125°C and using power supplies between 1.5V and 5.5V.

This circuit monitors the supply voltage of any electronic system, and generates the appropriate reset signal after a fixed reset timeout period. The threshold defines the minimum allowed voltage which guarantees the good functionality of the system. When V_{DD} rises above V_{TH} , the output remains active for an additional delay time. This allows the system to stabilize before getting fully active.

This circuit features a Manual Reset: an input that asserts reset when pulled low (\overline{MR} with internal pull-up).

Small SC70-5L and SOT23-5L packages as well as ultra-low supply current of 2.9µA make the EM6325 an ideal choice for portable and battery-operated devices.

Typical Application

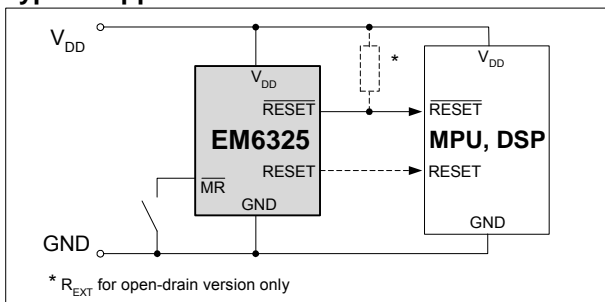

Block Diagram

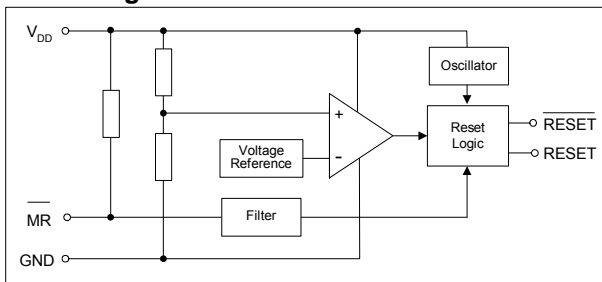

Features

- Manual reset function
- 200ms reset timeout period (1.6ms, 25ms, 1600ms on request)
- Ultra-low supply current of 2.9µA ($V_{DD}=3.3V$)
- Operating temperature range: -40°C to +125°C
- ±1.5% reset threshold accuracy
- 11 reset threshold voltages V_{TH} : 4.63V, 4.4V, 3.08V, 2.93V, 2.63V, 2.2V, 1.8V, 1.66V, 1.57V, 1.38V, 1.31V
- 2 reset output options:
 - Active-low \overline{RESET} push-pull
 - Active-low \overline{RESET} open-drain
- Immune to short negative V_{DD} transients
- Guaranteed Reset valid down to 0.9V
- Threshold hysteresis: 2.1% of V_{TH}
- Very small SOT23-5L, SC70-5L, SOT143-4L

Applications

- Computers
- Servers and workstations
- Modems
- Wireless communication
- Metering
- Playstations
- PDA , Webpad

Pin Configuration (top view)

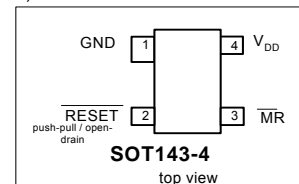
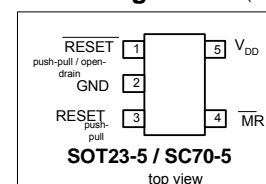

Pin Description

Pin		Name	Function
SOT23-5L / SC70-5L	SOT143-4L		
1	2	\overline{RESET}	Active-low \overline{RESET} output. \overline{RESET} remains low for the reset timeout period and then goes high after all reset conditions are deasserted or after \overline{MR} goes from low to high
2	1	GND	Ground
3		RESET	Active-high RESET output. RESET remains high for the reset timeout period and then goes low after all reset conditions are deasserted or after \overline{MR} goes from low to high
4	3	\overline{MR}	Manual Reset input with an internal pull-up 15kΩ resistor. Reset remains active as long as \overline{MR} is low and for t_{POR} after \overline{MR} returns high. \overline{MR} can be driven with a CMOS output or shorted to ground with a switch
5	4	V_{DD}	Supply Voltage (5.5V max.)



Ordering Information

EM6325 C X SP5B - 2.9 +

<p>Delay (t_{POR}): C = 200ms B = 25ms A = 1.6ms D = 1600ms</p> <p>Reset Output Type: X = Active-low /RES push-pull Active-high RES push-pull Y = Active-low /RES open-drain Active-high RES push-pull</p> <p>Package: SP5B = SOT23-5, Tape&Reel 3000 pcs SC5B = SC70-5, Tape&Reel 3000 pcs SK4B = SOT143-4, Tape&Reel 3000 pcs</p>	<p>RoHS Compliance: + = lead-free/green mold compliant [blank] = leaded</p> <p>Reset Threshold Voltage (V_{TH}):</p> <table border="0" style="width: 100%;"> <tr> <td>1.3 = 1.31V</td> <td>2.6 = 2.63V</td> </tr> <tr> <td>1.4 = 1.38V</td> <td>2.9 = 2.93V</td> </tr> <tr> <td>1.6 = 1.57V</td> <td>3.1 = 3.08V</td> </tr> <tr> <td>1.7 = 1.66V</td> <td>4.4 = 4.40V</td> </tr> <tr> <td>1.8 = 1.80V</td> <td>4.6 = 4.63V</td> </tr> <tr> <td>2.2 = 2.20V</td> <td></td> </tr> </table>	1.3 = 1.31V	2.6 = 2.63V	1.4 = 1.38V	2.9 = 2.93V	1.6 = 1.57V	3.1 = 3.08V	1.7 = 1.66V	4.4 = 4.40V	1.8 = 1.80V	4.6 = 4.63V	2.2 = 2.20V	
1.3 = 1.31V	2.6 = 2.63V												
1.4 = 1.38V	2.9 = 2.93V												
1.6 = 1.57V	3.1 = 3.08V												
1.7 = 1.66V	4.4 = 4.40V												
1.8 = 1.80V	4.6 = 4.63V												
2.2 = 2.20V													

Standard Versions (Top Marking)

Part Number	Top Marking ¹⁾	Top Marking ²⁾ with 4 Characters
EM6325AXSP5B-2.9+	CN##	BNAH
EM6325AXSP5B-3.1+	CA##	BNAJ
EM6325CXSC5B-2.6+	CS##	BNCG
EM6325CXSC5B-2.9+	BZ##	BNCH
EM6325CXSP5B-1.3+	CP##	BNCA
EM6325CXSP5B-2.6+	CS##	BNCG
EM6325CXSP5B-2.9+	BZ##	BNCH
EM6325CXSP5B-3.1+	CT##	BNCJ
EM6325CXSP5B-4.6+	C3##	BNCL
EM6325CYSP5B-2.9+	BY##	BNCU
EM6325CYSP5B-4.6+	C0##	BNCX
EM6325CXSK4B-2.9+	CR##	

- 1) Top marking is the standard from 2006. No bottom marking exists. Where ## refers to the lot number (EM internal reference only)
- 2) Top marking with 4 characters is standard from 2003. For lead-free/green mold (RoHS) parts, the first letter of top marking with 4 characters begins with letter "B" instead of letter "A". Bottom marking indicates the lot number.

Standard Versions (samples)

Part Number
EM6325AXSP5B-2.9+
EM6325AXSP5B-3.1+
EM6325CXSC5B-2.6+
EM6325CXSC5B-2.9+
EM6325CXSP5B-1.3+
EM6325CXSK4B-2.9+

Part Number
EM6325CXSP5B-2.6+
EM6325CXSP5B-2.9+
EM6325CXSP5B-3.1+
EM6325CXSP5B-4.6+
EM6325CYSP5B-2.6+
EM6325CYSP5B-4.6+

Sample stock is generally held on **standard versions** only. Please contact factory for other versions not shown here and for availability of non standard versions.



Absolute Maximum Ratings

Parameter	Symbol	Conditions
Voltage at V_{DD} to GND	V_{DD}	-0.3V to +6V
Minimum voltage at any signal pin	V_{MIN}	GND - 0.3V
Maximum voltage at any signal pin	V_{MAX}	$V_{DD} + 0.3V$
Electrostatic discharge max. to MIL-STD-883C method 3015.7 with ref. to V_{SS}	V_{ESD}	2000V
Max. soldering conditions	T_{MAX}	250°C x 10s
Storage Temperature Range	T_{STG}	-65°C to +150°C

Stresses above these listed maximum ratings may cause permanent damages to the device. Exposure beyond specified operating conditions may affect device reliability or cause malfunction.

Handling Procedures

This device has built-in protection against high static voltages or electric fields; however, anti-static precautions must be taken as for any other CMOS component. Unless otherwise specified, proper operation can only occur when all terminal voltages are kept within the voltage range. Unused inputs must always be tied to a defined logic voltage level.

Operating Conditions

Parameter	Symbol	Min	Max	Unit
Supply voltage	V_{DD}	0.9	5.5	V
Operating Temperature	T_A	-40	+125	°C

Electrical Characteristics

Unless otherwise specified: $V_{DD} = 0.9V$ to $5.5V$, $T_A = -40°C$ to $+125°C$ (note 1).

Parameter	Symbol	Conditions	Min	Typ	Max	Unit	
Supply current (note 2)	I_{DD}	$V_{DD} = 1.5V$	+25°C	-	2.3	4.6	μA
			-40°C to +125°C	-	-	7	
		$V_{DD} = 3.3V$	+25°C	-	2.9	5.5	
			-40°C to +125°C	-	-	8.3	
		$V_{DD} = 5.0V$	+25°C	-	3.4	6.3	
			-40°C to +125°C	-	-	9.6	
Threshold voltage (note 3)	V_{TH}	EM6325 – 1.3	+25°C	1.290	1.31	1.330	V
			-40°C to +85°C	1.245		1.382	
			-40°C to +125°C	1.221		1.387	
		EM6325 – 1.4	+25°C	1.359	1.38	1.401	
			-40°C to +85°C	1.311		1.456	
			-40°C to +125°C	1.286		1.461	
		EM6325 – 1.6	+25°C	1.546	1.57	1.594	
			-40°C to +85°C	1.492		1.656	
			-40°C to +125°C	1.463		1.663	
		EM6325 – 1.7	+25°C	1.635	1.66	1.685	
			-40°C to +85°C	1.577		1.751	
			-40°C to +125°C	1.547		1.758	
		EM6325 – 1.8	+25°C	1.773	1.80	1.827	
			-40°C to +85°C	1.710		1.899	
			-40°C to +125°C	1.678		1.906	
		EM6325 – 2.2	+25°C	2.167	2.20	2.233	
			-40°C to +85°C	2.090		2.321	
			-40°C to +125°C	2.050		2.330	
		EM6325 – 2.6	+25°C	2.591	2.63	2.669	
			-40°C to +85°C	2.499		2.775	
			-40°C to +125°C	2.451		2.785	
		EM6325 – 2.9	+25°C	2.886	2.93	2.974	
			-40°C to +85°C	2.784		3.091	
			-40°C to +125°C	2.731		3.103	
		EM6325 – 3.1	+25°C	3.034	3.08	3.126	
			-40°C to +85°C	2.926		3.249	
			-40°C to +125°C	2.871		3.262	
		EM6325 – 4.4	+25°C	4.334	4.40	4.466	
			-40°C to +85°C	4.180		4.642	
			-40°C to +125°C	4.101		4.660	
EM6325 – 4.6	+25°C	4.561	4.63	4.699			
	-40°C to +85°C	4.399		4.885			
	-40°C to +125°C	4.315		4.903			
Threshold hysteresis	V_{HYS}	$T_A = +25°C$	-	$2.1\% \cdot V_{TH}$	-	V	

Note 1: Production tested at +25°C only. Over temperature limits are guaranteed by design, not production tested.

Note 3: Threshold voltage is specified for V_{DD} falling.



Electrical Characteristics (continued)

Unless otherwise specified: $V_{DD} = 0.9V$ to $5.5V$, $T_A = -40^{\circ}C$ to $+125^{\circ}C$ (note 1).

Parameter	Symbol	Conditions		Min	Typ	Max	Unit
Reset timeout period	t_{POR}	(note 2 and 4) V_{DD} from 0V to $V_{TH(typ)}+15\%$ $T_A = +25^{\circ}C$	EM6325C	155	200	224	ms
			EM6325A	0.7	1.6	3.8	
			EM6325B	19.4	25	28	
			EM6325D	1240	1600	1792	
Propagation delay time V_{DD} to \overline{RESET} (RESET) delay	t_p	V_{DD} drops from $V_{TH(typ)}+0.2V$ to $V_{TH(typ)}-0.2V$ (note 2). $T_A = +25^{\circ}C$		2	130	255	μs
Open-drain \overline{RESET} output Voltage	V_{OL}	$V_{DD} > 1V$	$I_{OL} = 100\mu A$	-	-	0.3	V
		$V_{DD} > 2.5V$	$I_{OL} = 1.5mA$	-	-	0.3	
		$V_{DD} > 5V$	$I_{OL} = 3mA$	-	-	0.35	
Push-pull \overline{RESET} / \overline{RESET} Output voltage	V_{OL}	$V_{DD} > 1V$	$I_{OL} = 100\mu A$	-	-	0.3	V
		$V_{DD} > 2.5V$	$I_{OL} = 1.5mA$	-	-	0.3	
		$V_{DD} > 5V$	$I_{OL} = 3mA$	-	-	0.35	
	V_{OH}	$V_{DD} > 1V$	$I_{OH} = -30\mu A$	0.8	-	-	
		$V_{DD} > 2.5V$	$I_{OH} = -1.5mA$	2	-	-	
		$V_{DD} > 5V$	$I_{OH} = -3mA$	4	-	-	
Output leakage current	I_{LEAK}	Only for EM6325_Y (open-drain)		-	-	0.5	μA
MANUAL RESET (MR)							
\overline{MR} Input low	$V_{MRT\ low}$	$T_A = +25^{\circ}C$				$0.3 \cdot V_{DD}$	V
\overline{MR} Input high	$V_{MRT\ high}$			$0.7 \cdot V_{DD}$			V
\overline{MR} to Reset delay	t_{MD}				0.3		μs
Pulse width at MR (note 5)	t_{PMD}			1			μs
\overline{MR} Internal Pull-up resistor	R_{MR}	$T_A = -40^{\circ}C$ to $+125^{\circ}C$		4.8	15	31	$k\Omega$

Note 1: Production tested at $+25^{\circ}C$ only. Over temperature limits are guaranteed by design, not production tested.

Note 2: \overline{RESET} (RESET) open.

Note 4: Standard version for t_{POR} is 200ms (typ), available at all times. Other option (1.6ms, 25ms, 1600ms) are available by mask option and upon minimum order quantity. Please contact EM sales.

Note 5: Pulse width must be greater than $1\mu s$ to ensure the \overline{RESET} (RESET) to go active.

Timing Waveforms

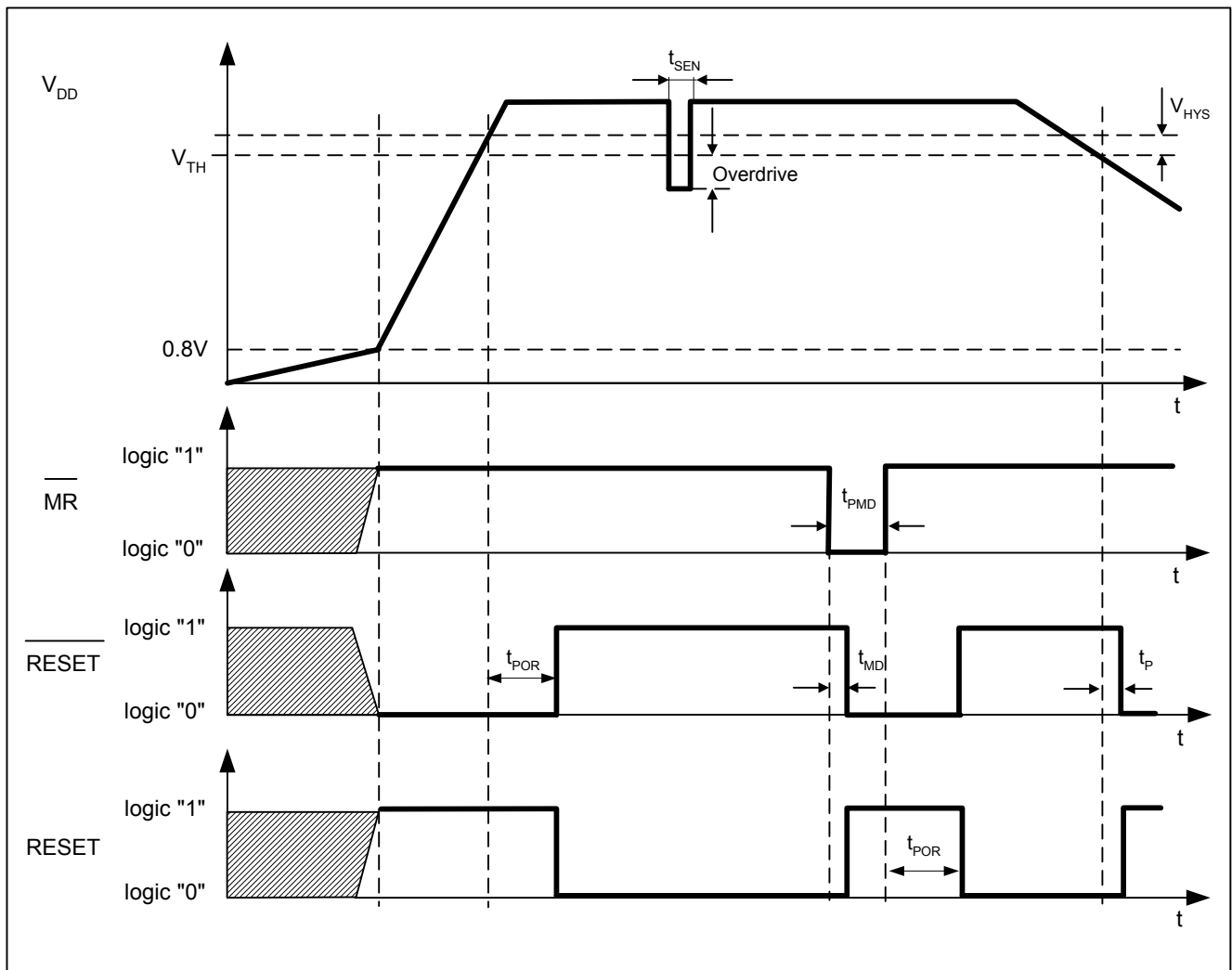

Note 6: t_{SEN} = Maximum Transient Duration. Please refer to figure on the next page.

Note 7: Overdrive = $V_{TH} - V_{DD}$. Please refer to figure on the next page.

Manual Reset Input

A logic low on \overline{MR} asserts a reset. Reset remains asserted while \overline{MR} is low, and for t_{POR} (200ms nominal for EM6325C) after it returns high. \overline{MR} has an internal 15k Ω pull-up resistor, so it can be left open if unused. This input can be driven with CMOS logic levels or with open-drain outputs. Connect a normally open momentary switch from \overline{MR} to V_{SS} to create a manual-reset function; debounce circuitry is integrated. If \overline{MR} is driven from long cable or the device is used in a noisy environment, connect a 0.1 μ F capacitor from \overline{MR} to V_{SS} to provide additional noise immunity (stronger external additional pull-up resistor can also be added).



Typical Operating Characteristics

(Typical values are at $T_A=+25^\circ\text{C}$ unless otherwise noted, $\overline{\text{MR}}$, $\overline{\text{RESET}}$ and RESET open.)

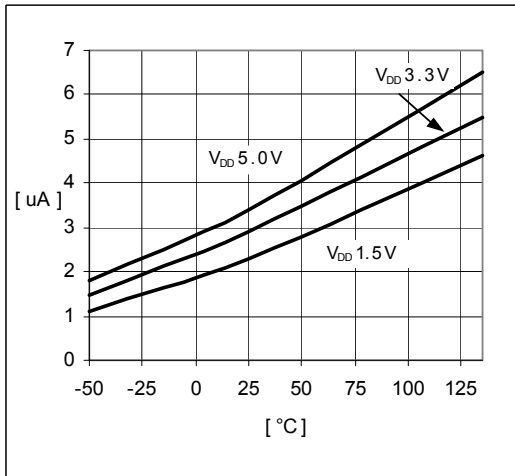

I_{DD} vs. Temperature

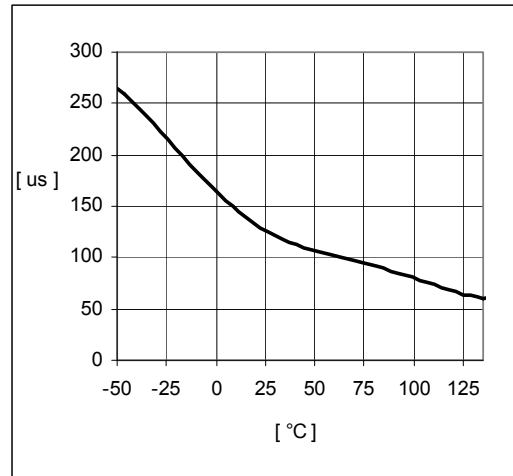

Propagation Time t_P vs. Temperature

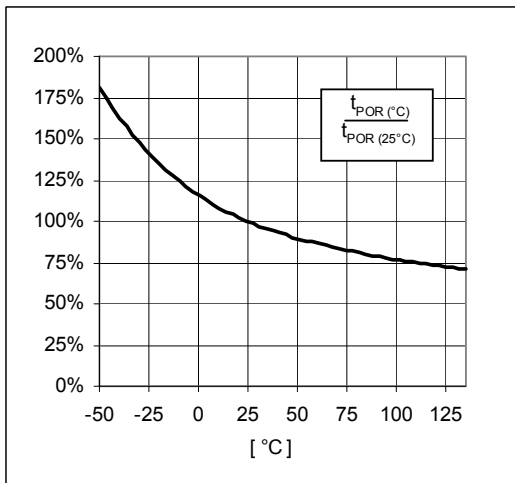

Reset Timeout Period t_{POR} vs. Temperature (normalized with respect to $t_{POR} 25^\circ\text{C}$)

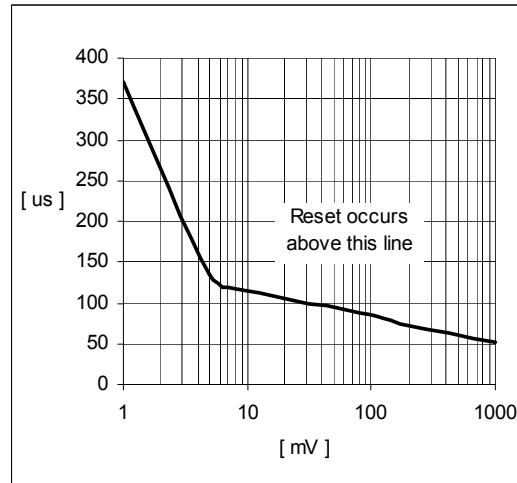

Maximum Transient Duration t_{SEN} vs. Overdrive $V_{TH} - V_{DD}$

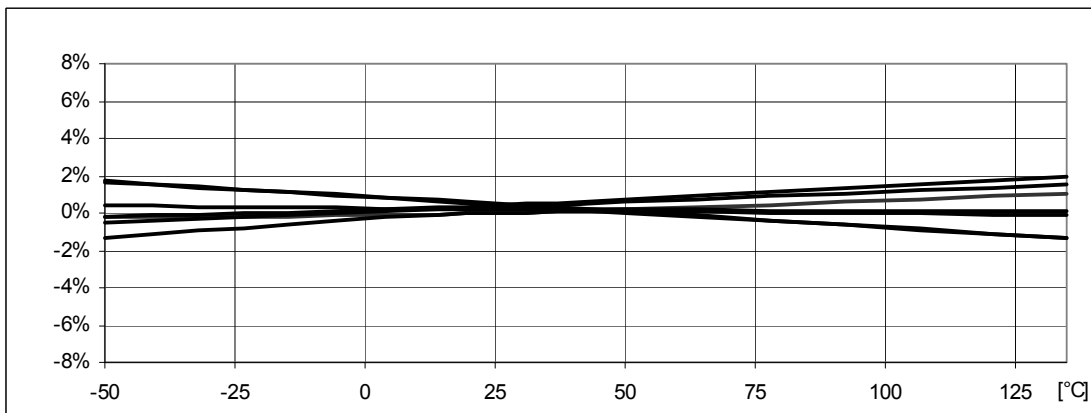

Threshold Voltage Variation vs. Temperature (normalized)

Package Information

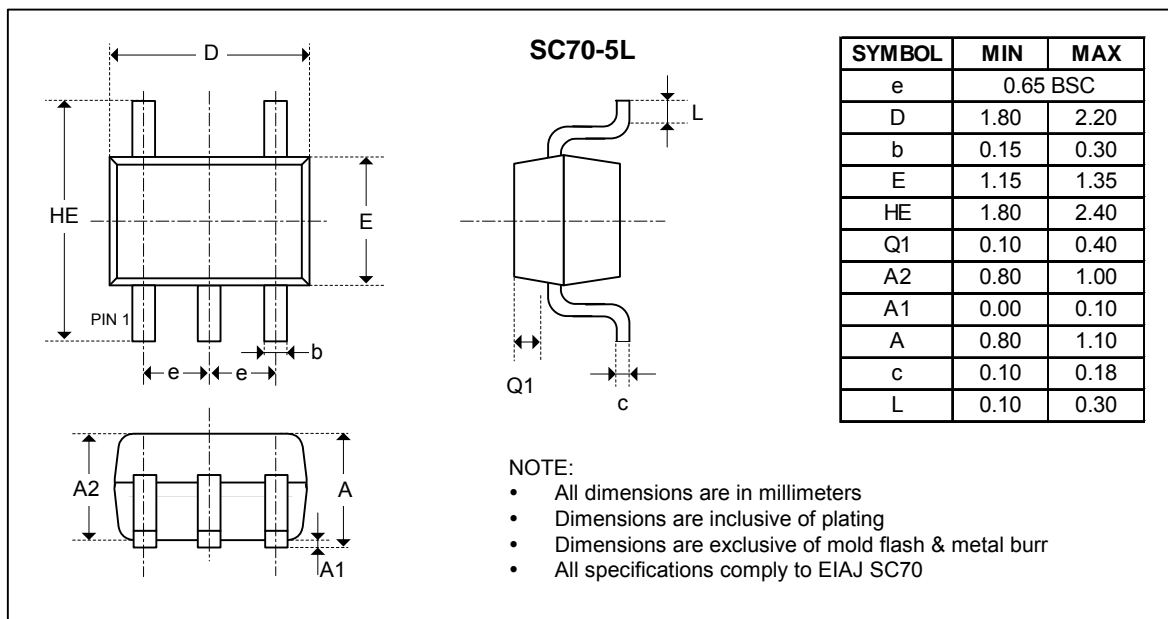
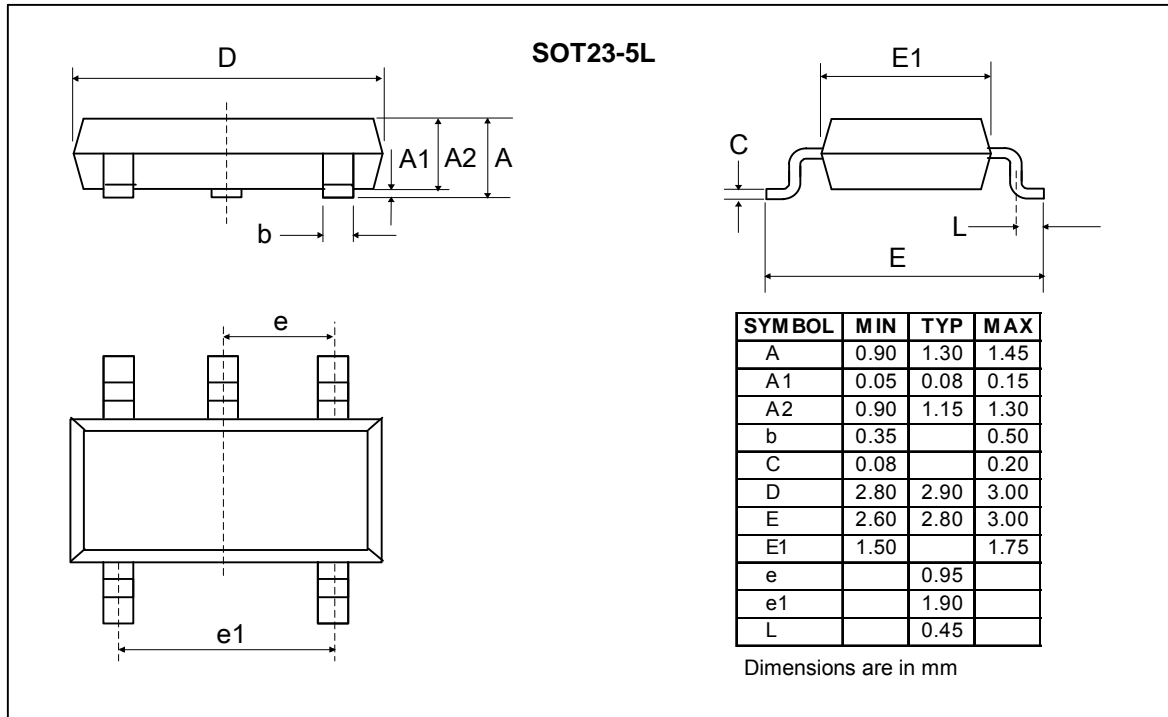

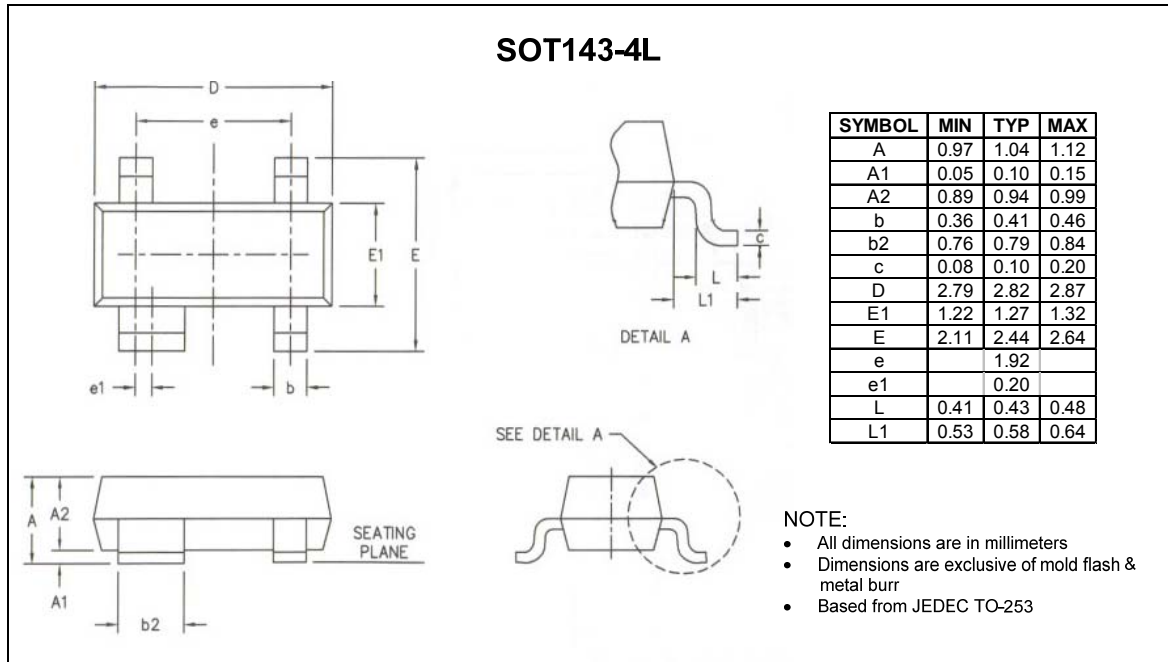

Traceability for small packages

Due to the limited space on the package surface, the bottom marking contains a limited number of characters that provide only partial information for lot traceability. Full information for complete traceability is however provided on the packing labels of the product at delivery from EM. It is highly recommended that the customer insures full lot traceability of EM product in his final product.

EM Microelectronic-Marin SA (EM) makes no warranty for the use of its products, other than those expressly contained in the Company's standard warranty which is detailed in EM's General Terms of Sale located on the Company's web site. EM assumes no responsibility for any errors which may appear in this document, reserves the right to change devices or specifications detailed herein at any time without notice, and does not make any commitment to update the information contained herein. No licenses to patents or other intellectual property of EM are granted in connection with the sale of EM products, expressly or by implications. EM's products are not authorized for use as components in life support devices or systems.

Product qualification is performed according to internal EM quality standards for industrial products. For any special requirement (eg. automotive grade) please contact EM Microelectronic-Marin S.A.