

Power source

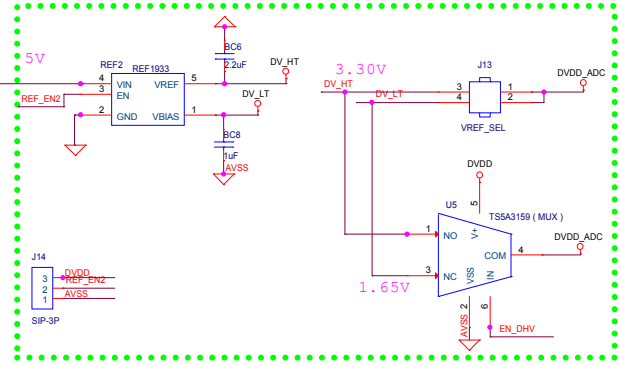

ADC SPI Control by MCU

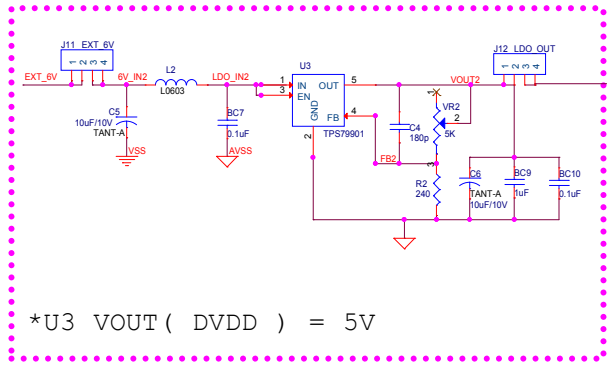
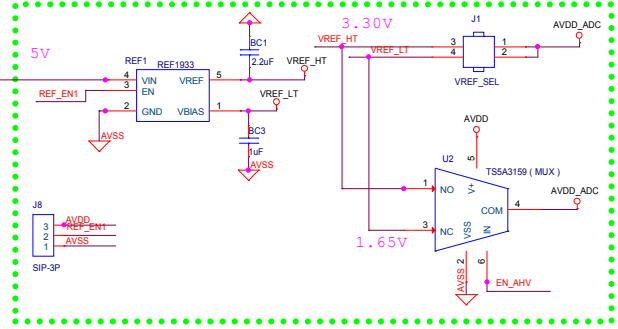
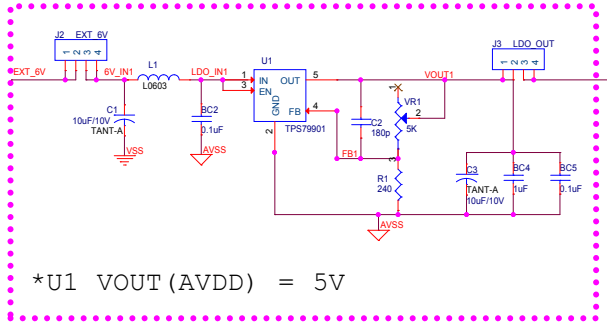
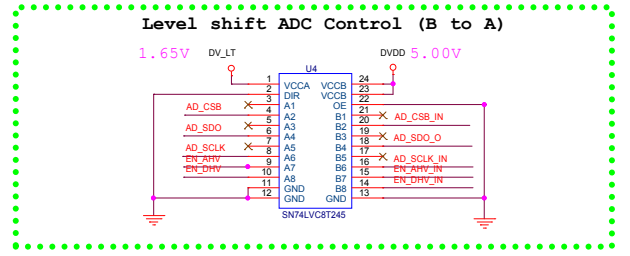
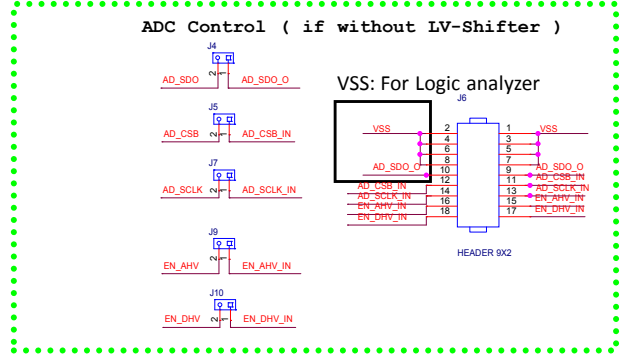

SIN or Ramp Input

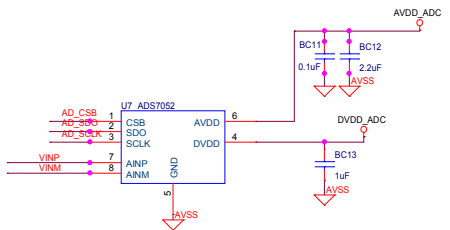
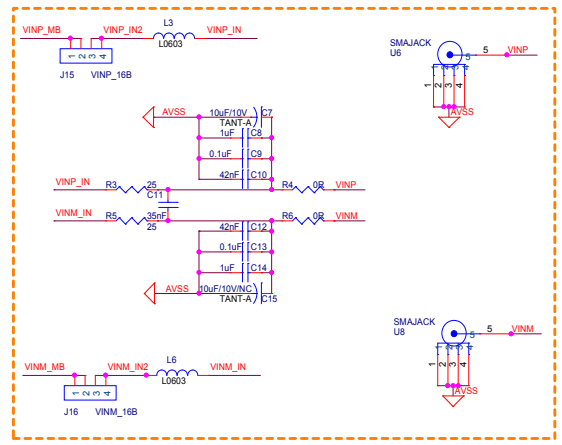

VSS: For external power supply & Logic analyzer
 AVSS: For ADC's power & Signal input

