 **TEXAS INSTRUMENTS**

Title: **COVER**

Drawn: L. NGUYEN 03/2017	Size B	Document Number TSW40RF82EVM	Rev A
Engineer: R. HOPPENSTEIN 03/2017	Date: Thursday, March 09, 2017	Sheet 1 of 15	

NOTES:

R1, R2, and R3 form 3dB pad by default.

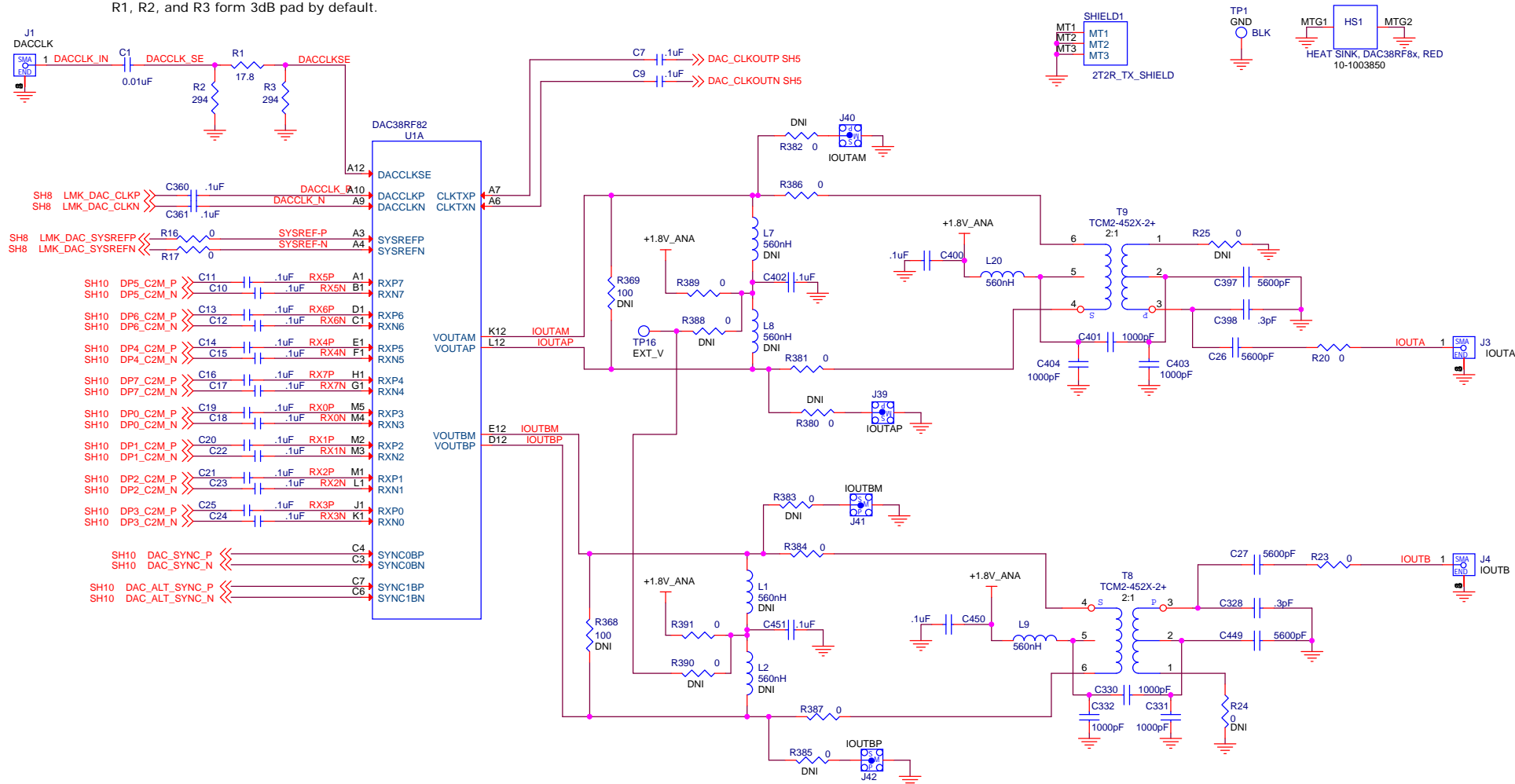

NOTES:

- 1) DNI = DO NOT INSTALL

TEXAS INSTRUMENTS

Title: DAC

Size: B Document Number: TSW40RF82EVM Rev: A

Date: Tuesday, March 14, 2017 Sheet: 2 of 15

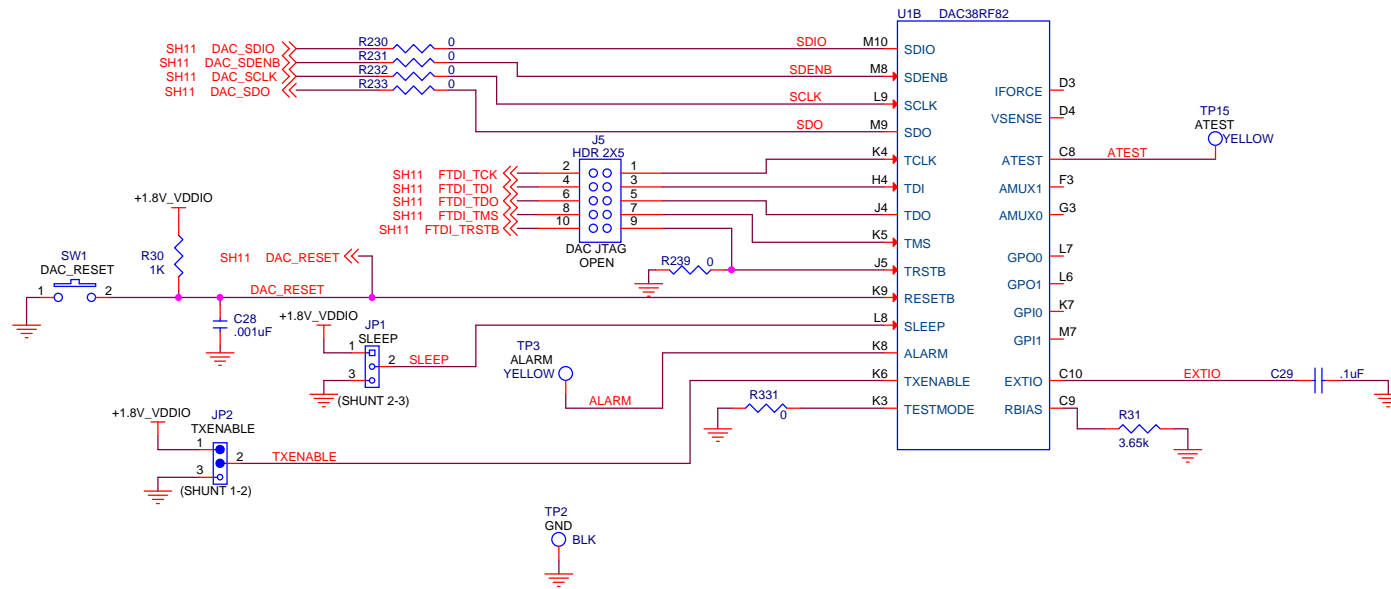

TEXAS INSTRUMENTS

Title		DAC	
Size	Document Number	Rev	
B	TSW40RF82EVM	A	
Date: Monday, February 13, 2017		Sheet	3 of 15

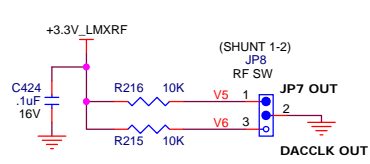
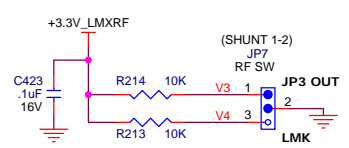
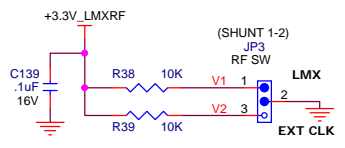
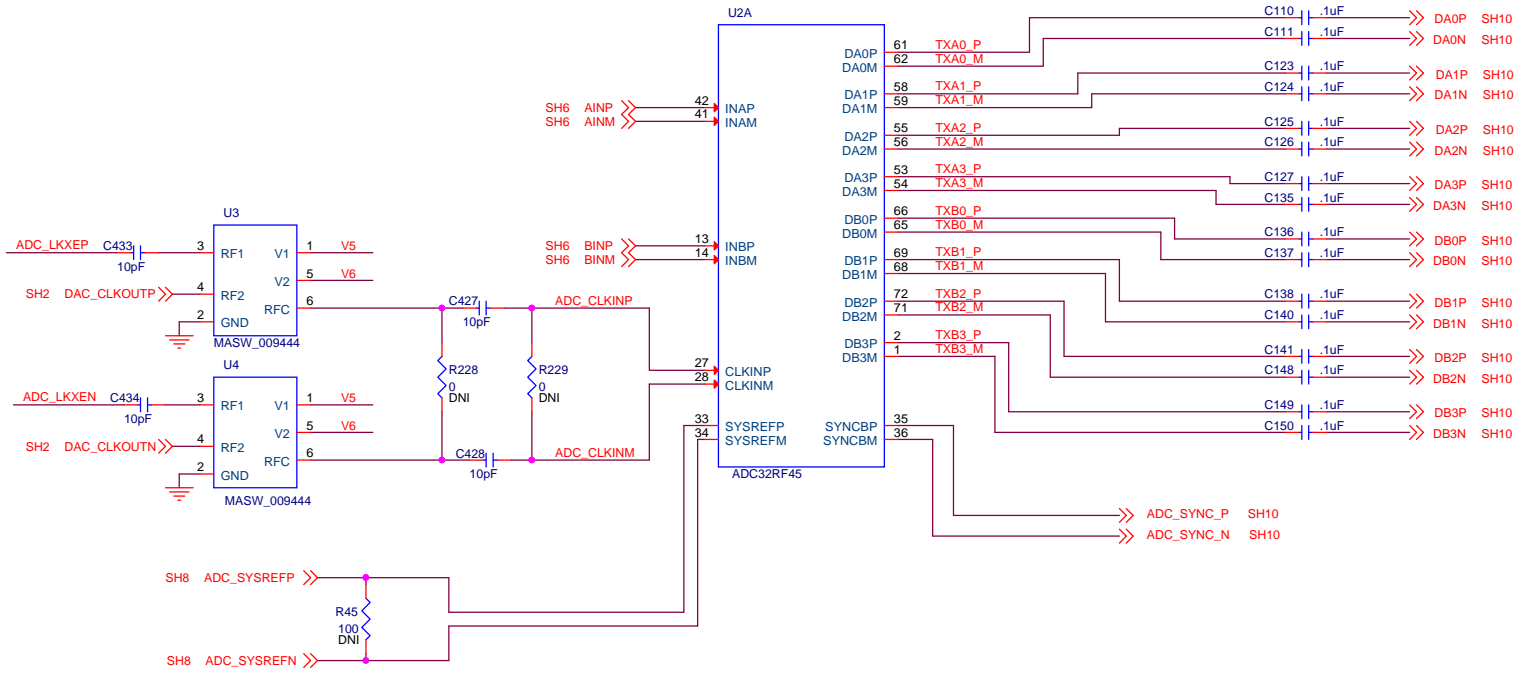
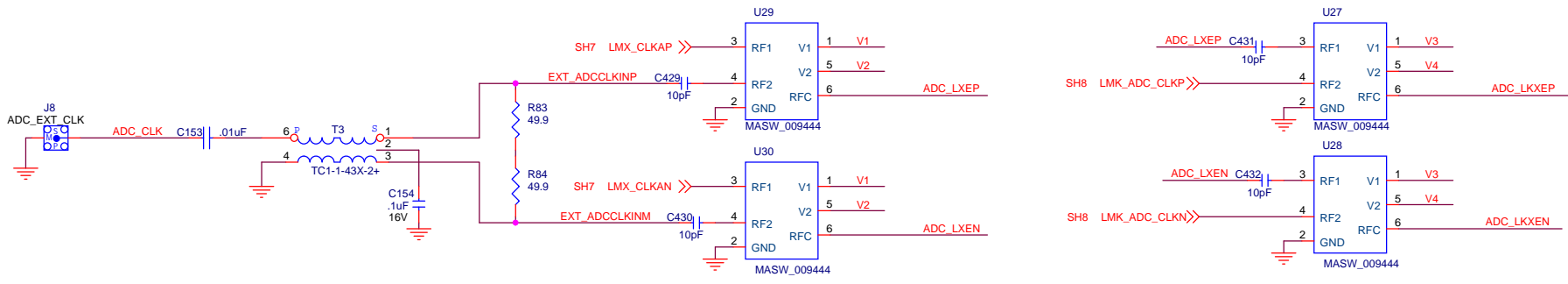

TEXAS INSTRUMENTS

Title: **ADC**

Size: **B** Document Number: **TSW40RF82EVM** Rev: **A**

Date: **Monday, February 13, 2017** Sheet **5** of **15**

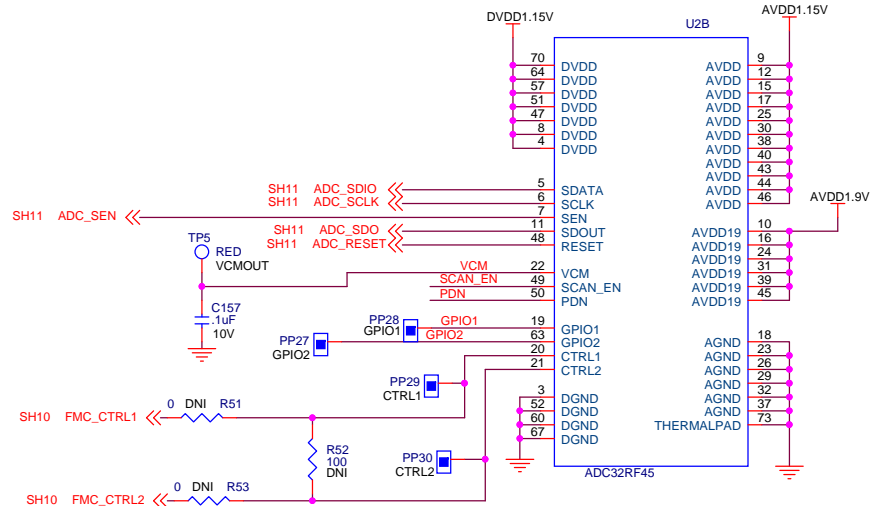
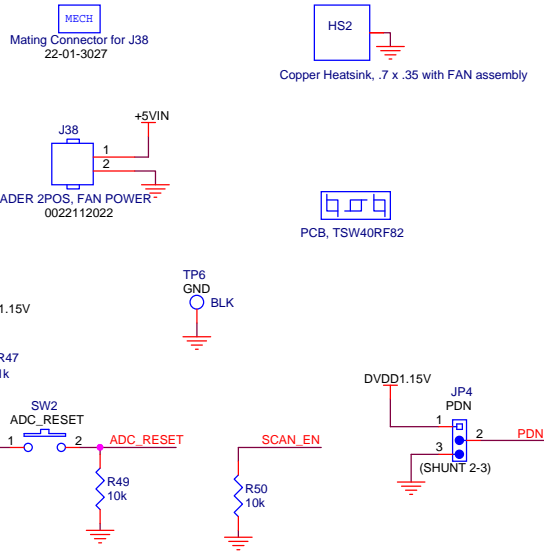
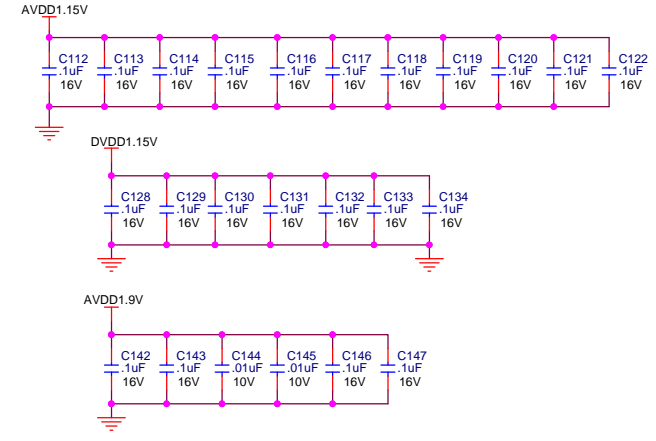
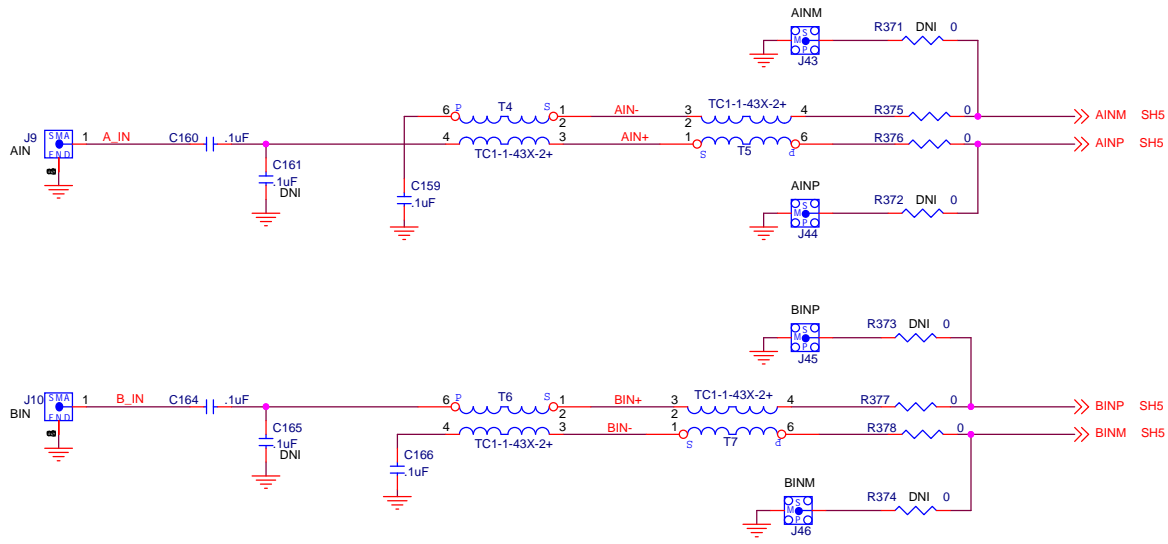

TEXAS INSTRUMENTS

Title: **ADC INPUT**

Size: B	Document Number: TSW40RF82EVM	Rev: A
Date: Thursday, March 09, 2017		Sheet: 6 of 15

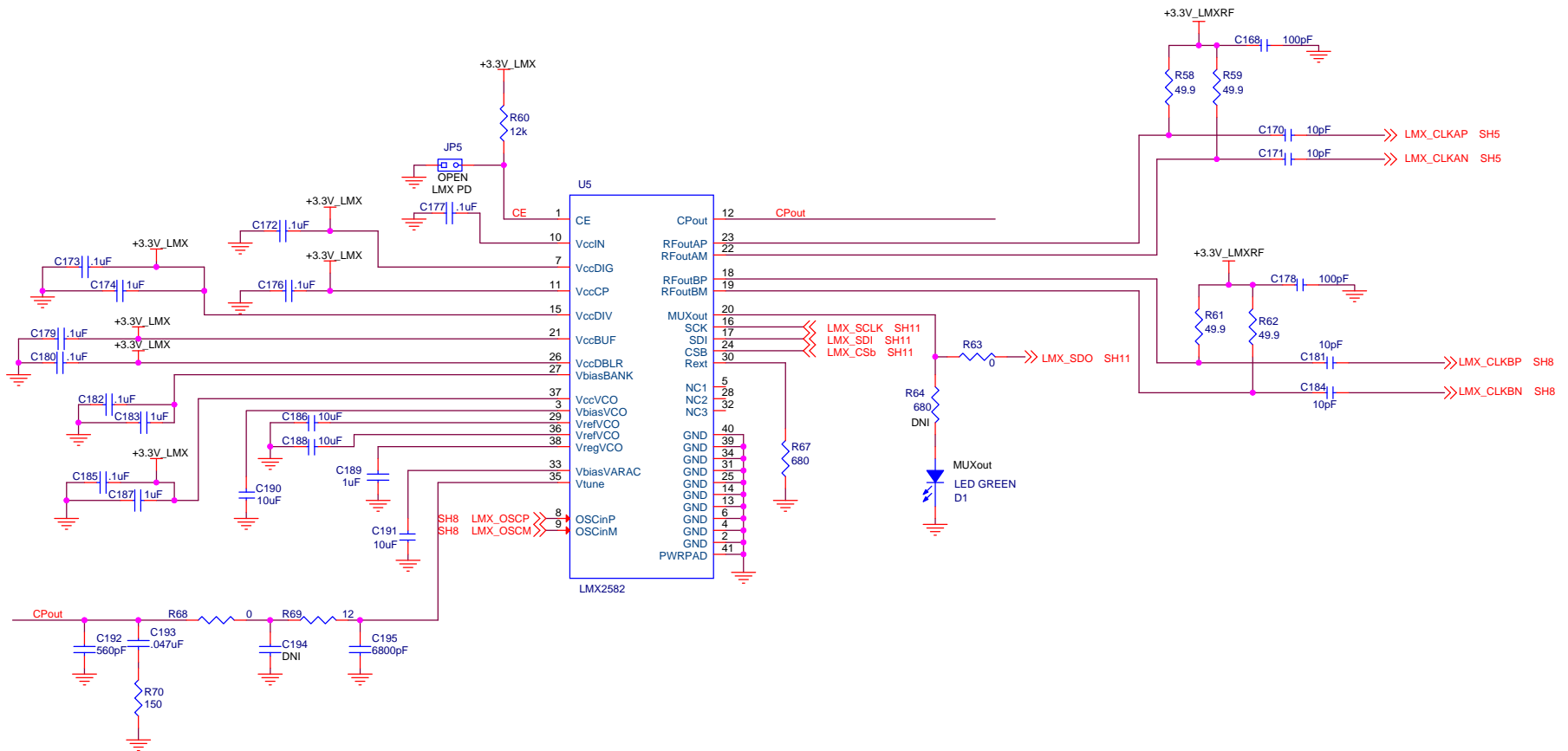

TEXAS INSTRUMENTS

Title: **LMX**

Size **B** Document Number **TSW40RF82EVM** Rev **A**

Date: Monday, February 13, 2017 Sheet 7 of 15

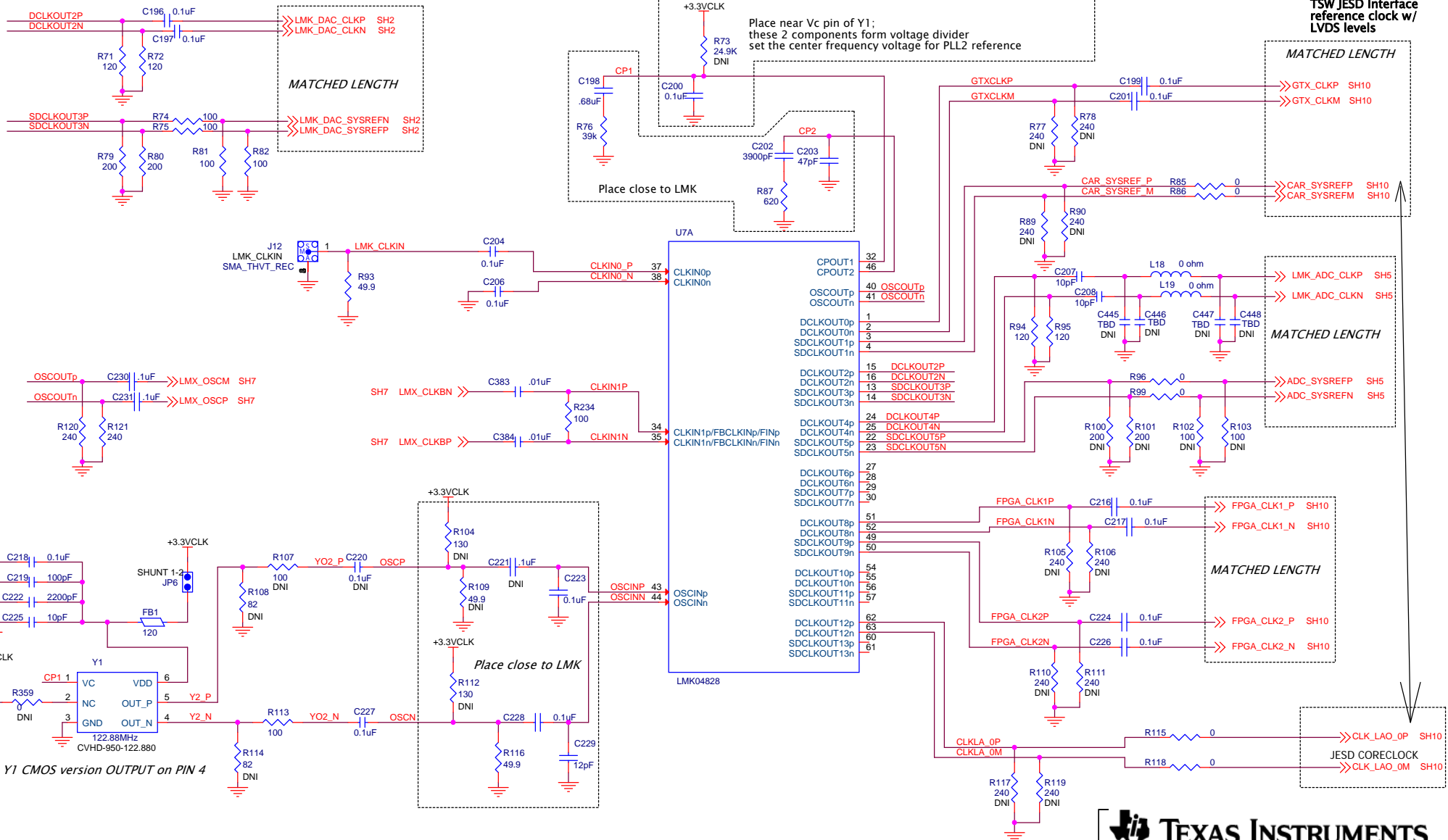

TSW JESD Interface reference clock w/ LVDS levels

MATCHED LENGTH

MATCHED LENGTH

MATCHED LENGTH

CLK_LAO_0P SH10
JESD CORECLOCK
CLK_LAO_0M SH10



Title			LMK		
Size	Document Number			Rev	
B	TSW40RF82EVM			A	
Date: Monday, February 13, 2017			Sheet	8	of 15

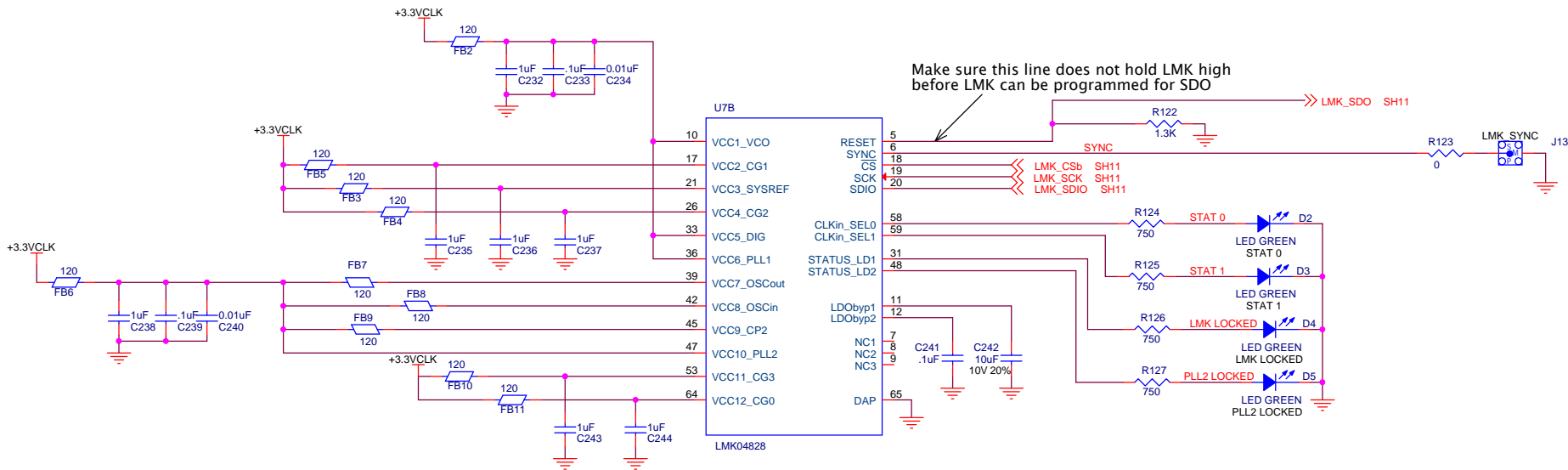

TEXAS INSTRUMENTS

Title: **LMK**

Size: **B** Document Number: **TSW40RF82EVM** Rev: **A**

Date: Monday, February 13, 2017 Sheet 9 of 15

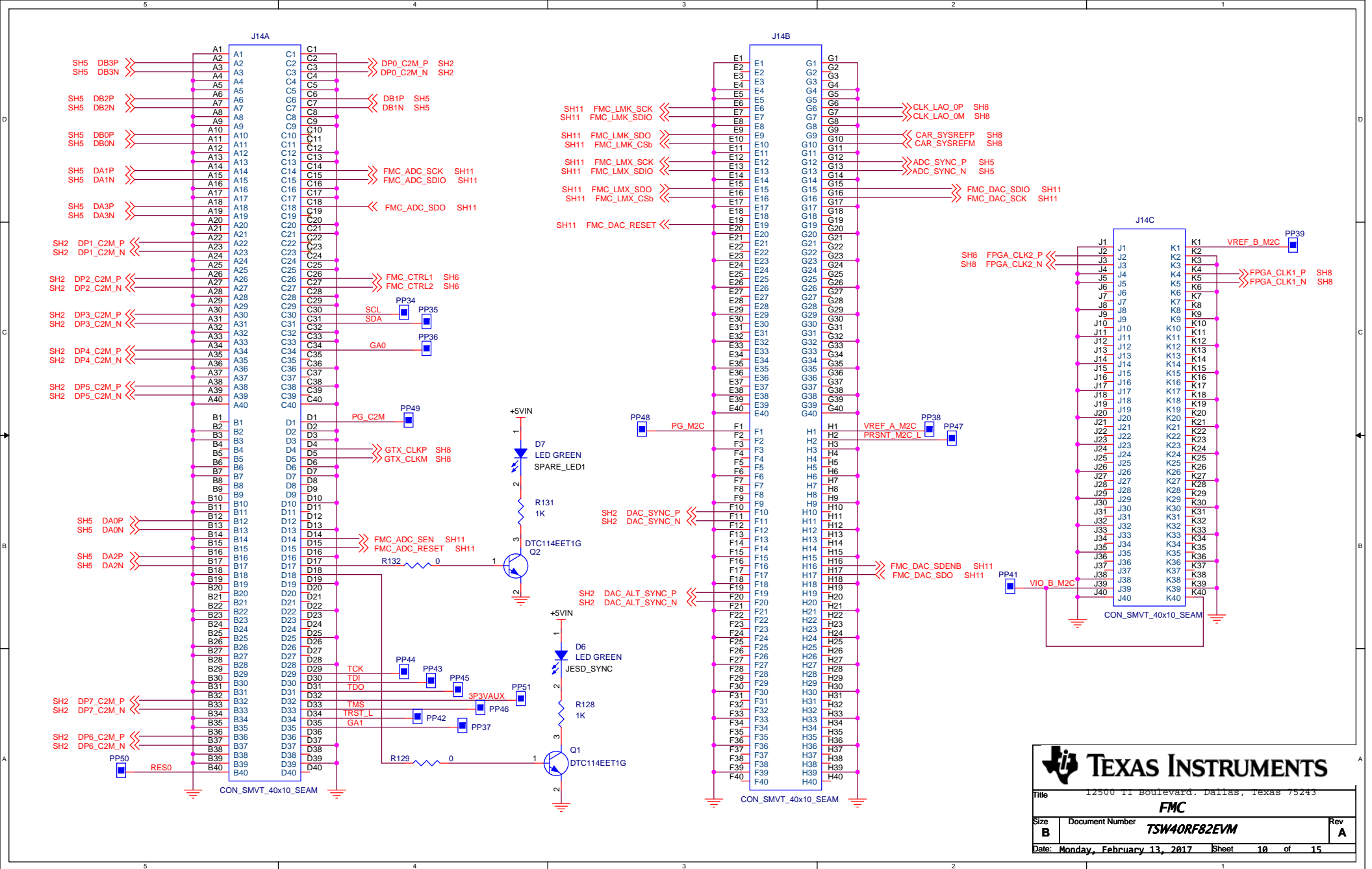

TEXAS INSTRUMENTS

Title 12500 TI Boulevard, Dallas, Texas 75243

FMC

Size B Document Number **TSW40RF82EVM** Rev A

Date: Monday, February 13, 2017 Sheet 10 of 15

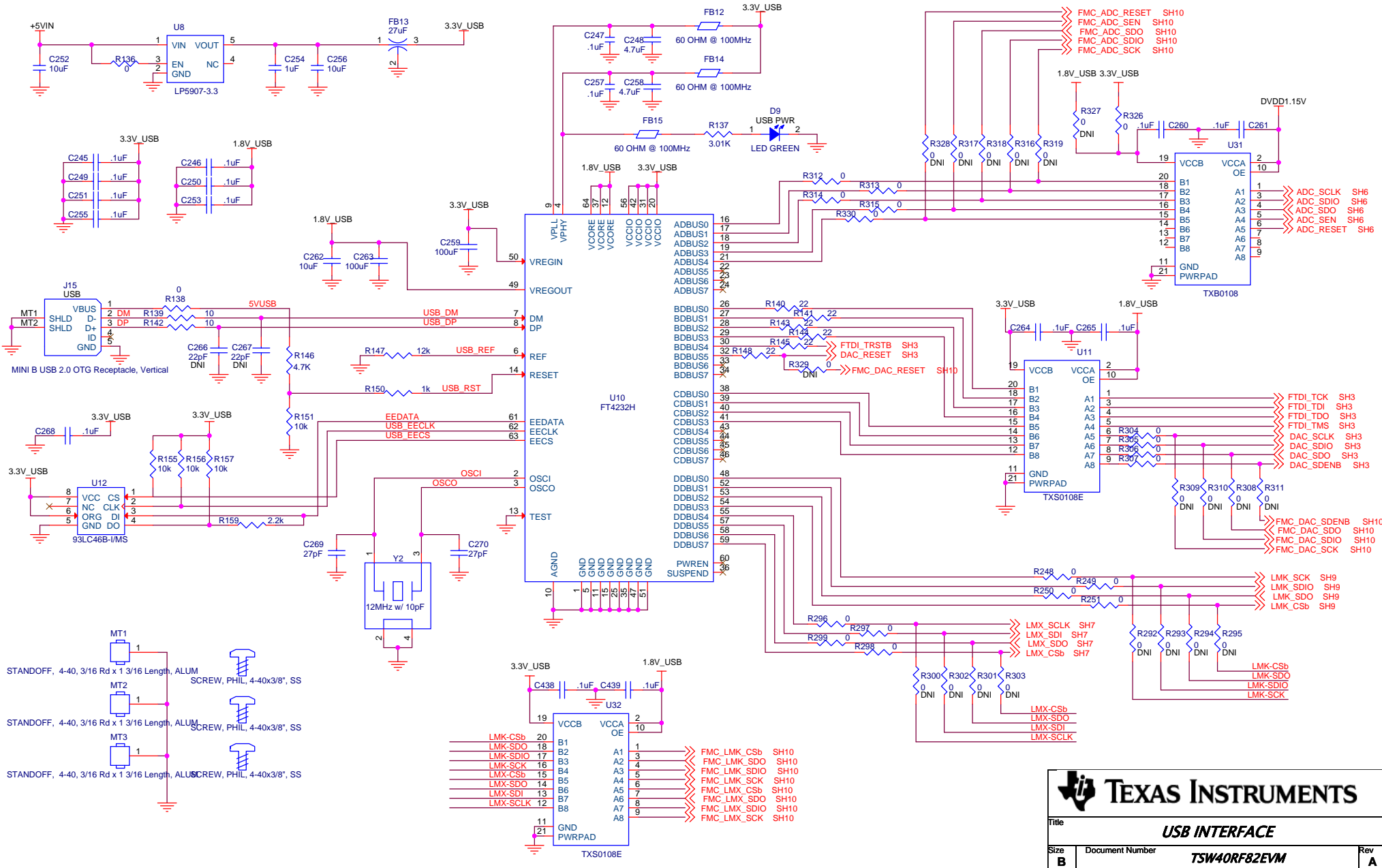

TEXAS INSTRUMENTS

Title: **USB INTERFACE**

Size B	Document Number TSW40RF82EVM	Rev A
Date: Monday, February 13, 2017		Sheet 11 of 15

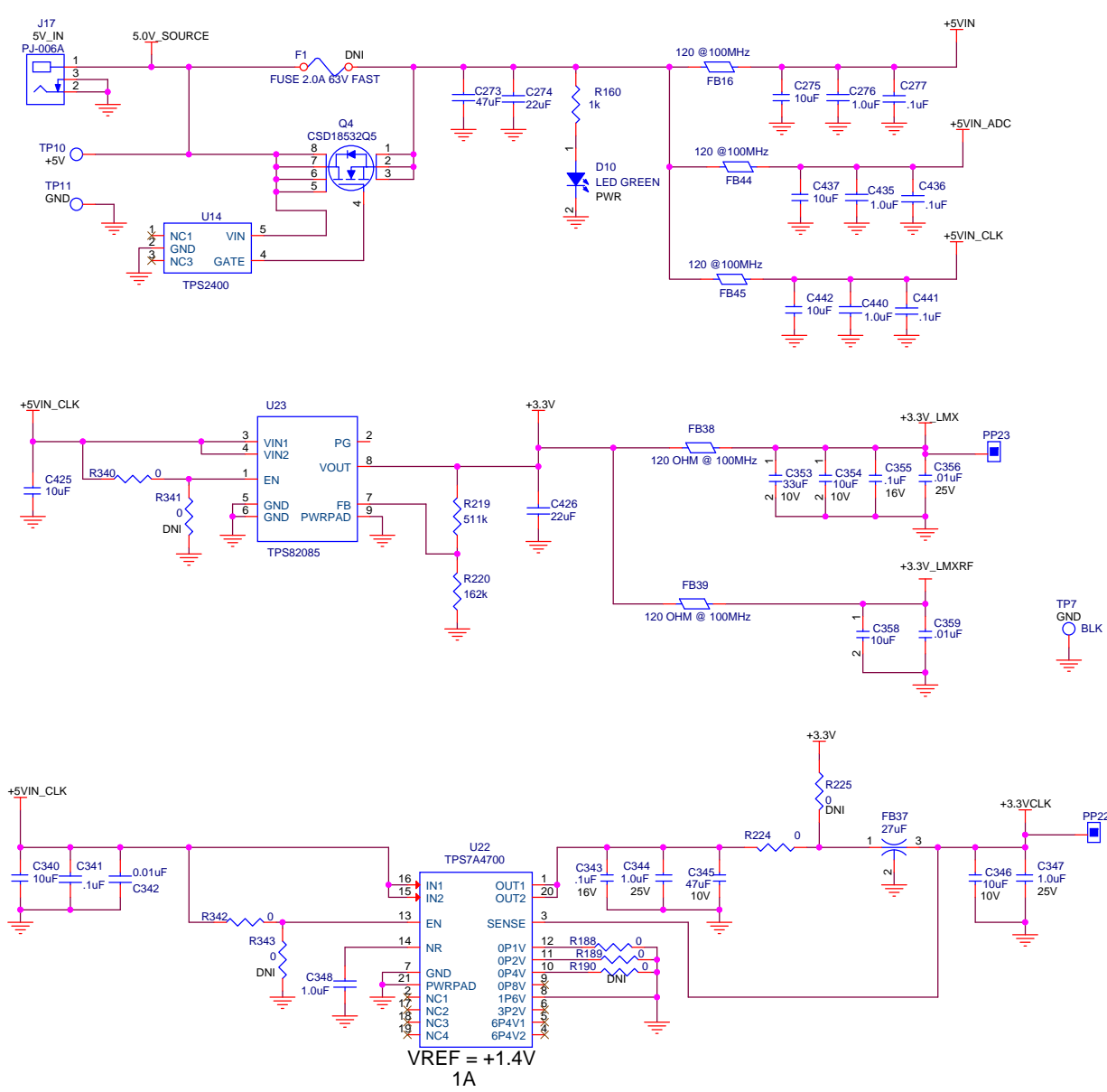

TEXAS INSTRUMENTS

Title: **POWER SUPPLIES - CLOCK**

Size **B** Document Number **TSW40RF82EVM** Rev **A**

Date: Friday, March 03, 2017 Sheet 12 of 15

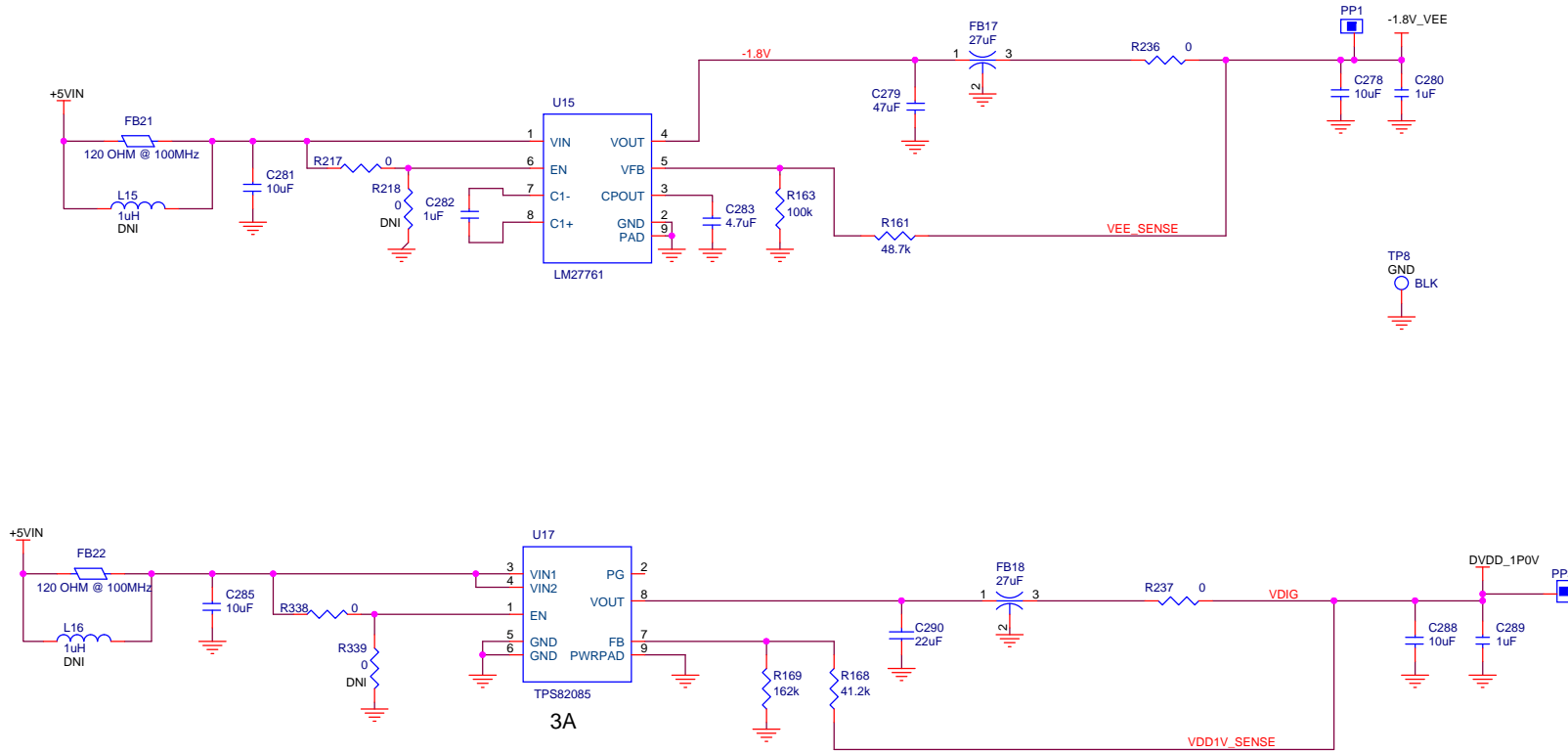

Title		
POWER SUPPLIES - DAC		
Size	Document Number	Rev
B	TSW40RF82EVM	A
Date: Monday, February 13, 2017		Sheet 13 of 15

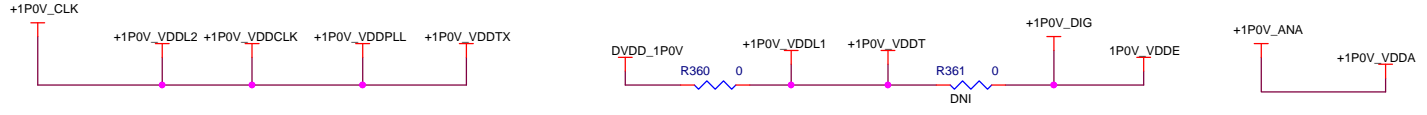
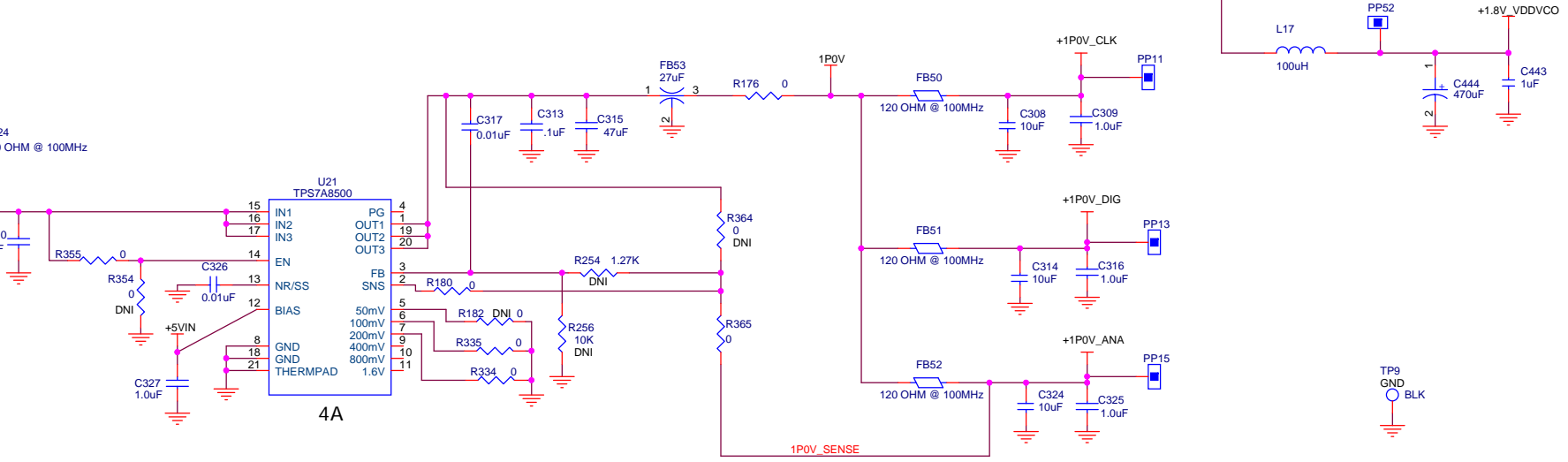
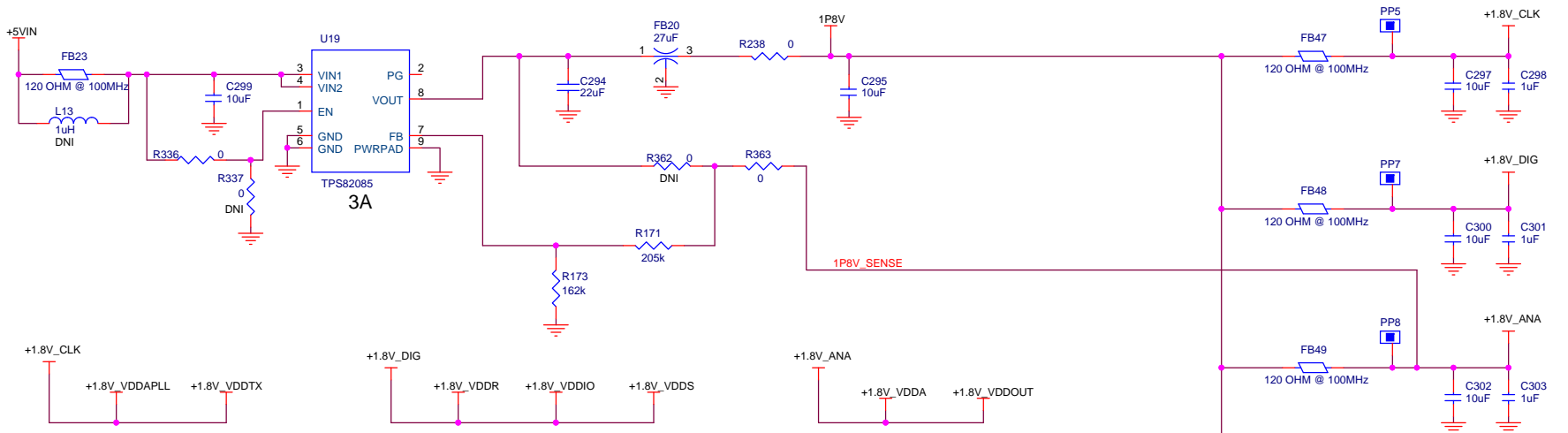

TEXAS INSTRUMENTS

Title: **POWER SUPPLIES - DAC**

Size: **B** Document Number: **TSW40RF82EVM** Rev: **A**

Date: **Monday, February 13, 2017** Sheet: **14** of **15**

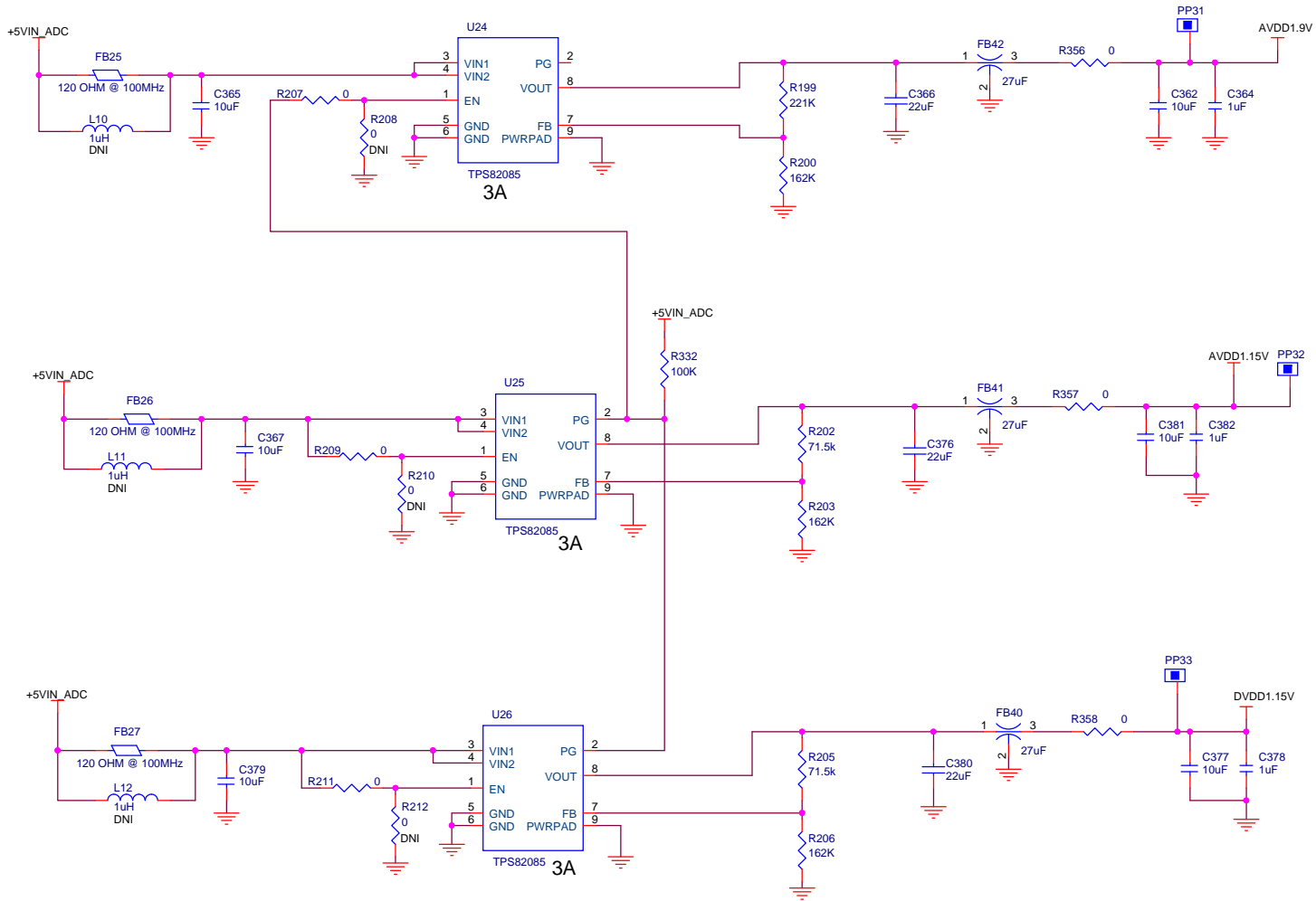

TEXAS INSTRUMENTS

Title: **POWER SUPPLIES - ADC**

Size: **B** Document Number: **TSW40RF82EVM** Rev: **A**

Date: Monday, February 13, 2017 Sheet 15 of 15