

GDT INTERFACE MODULE

ADC_DIFFERENTIAL_DRIVER

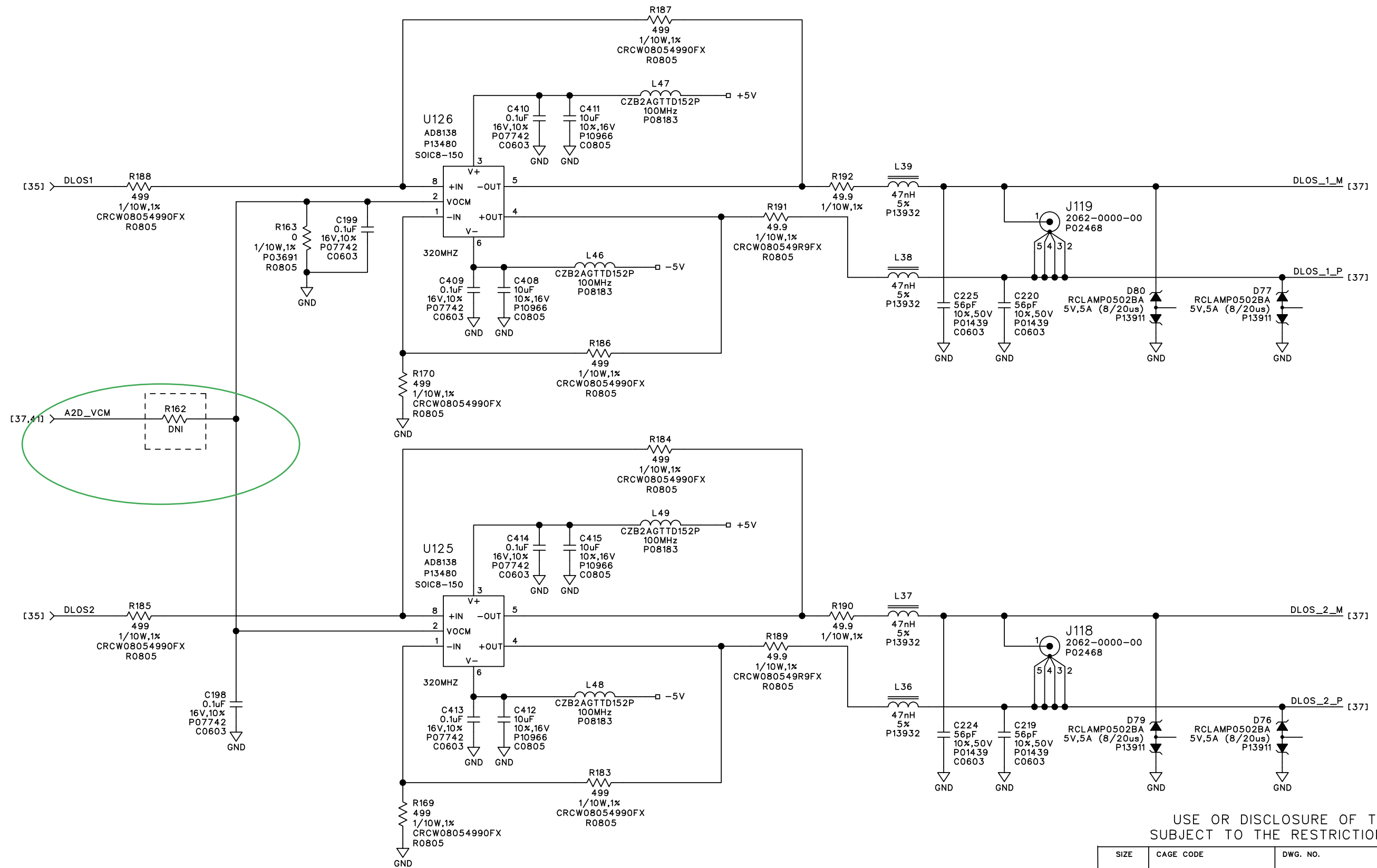

USE OR DISCLOSURE OF THIS DATA IS
SUBJECT TO THE RESTRICTIONS ON SHEET 1

SIZE	CAGE CODE	DWG. NO.	REV.
B	OYJB5	UXX13231	X1
SCALE: N/A		DWG FILE: UXX13181.SCH	SHEET 36 OF 50

GDT INTERFACE MODULE

DLOS_DATA_ADC

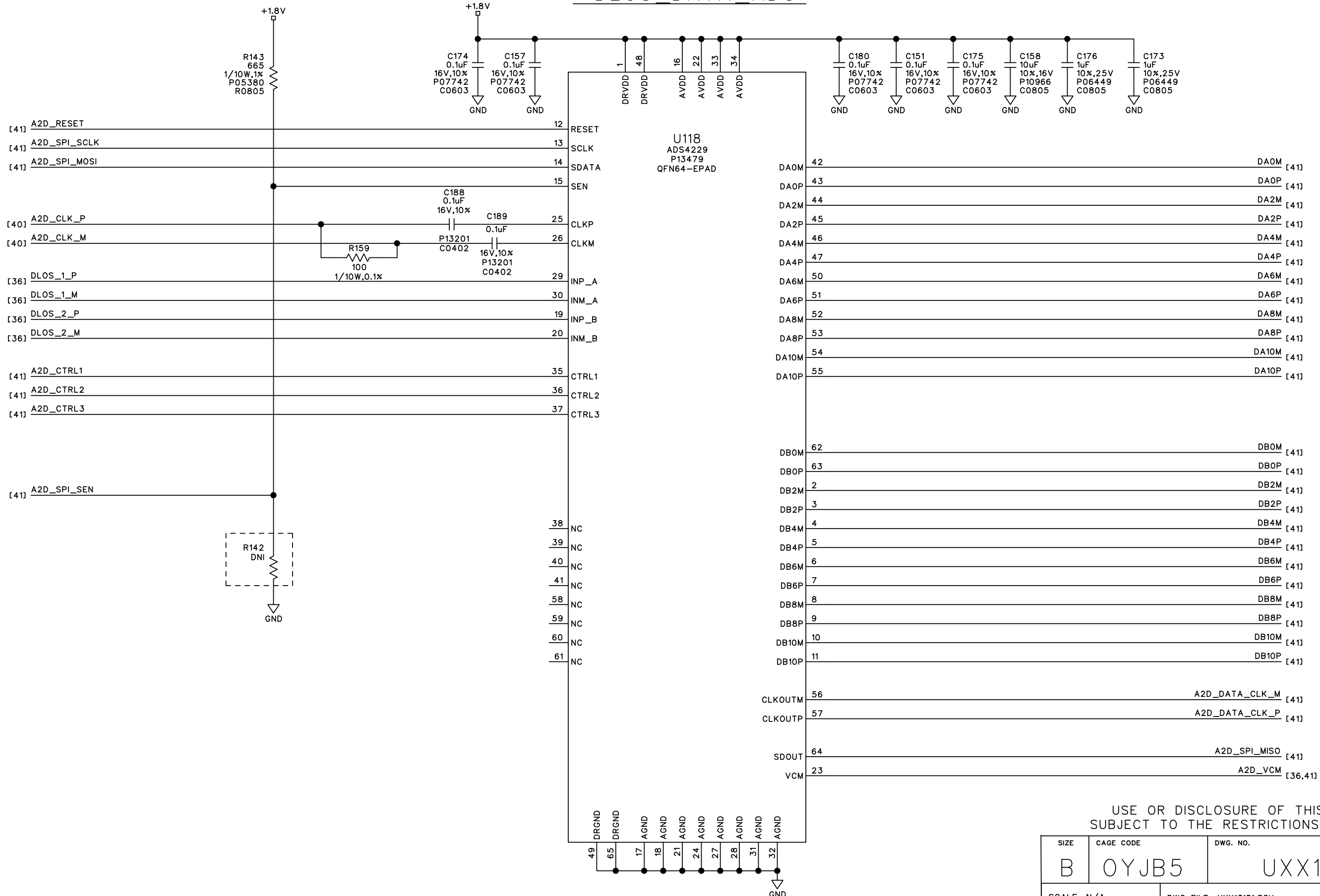

USE OR DISCLOSURE OF THIS DATA IS
SUBJECT TO THE RESTRICTIONS ON SHEET 1

SIZE	CAGE CODE	DWG. NO.	REV.
B	OYJB5	UXX13231	X1
SCALE: N/A		DWG FILE: UXX13181.SCH	SHEET 37 OF 50