

Sheet: /power/  
File: power.kicad\_sch

**Title: System**

Size: A4 Date: 2026-01-26

KiCad E.D.A. 9.0.7

Rev: 1

Id: 3/5

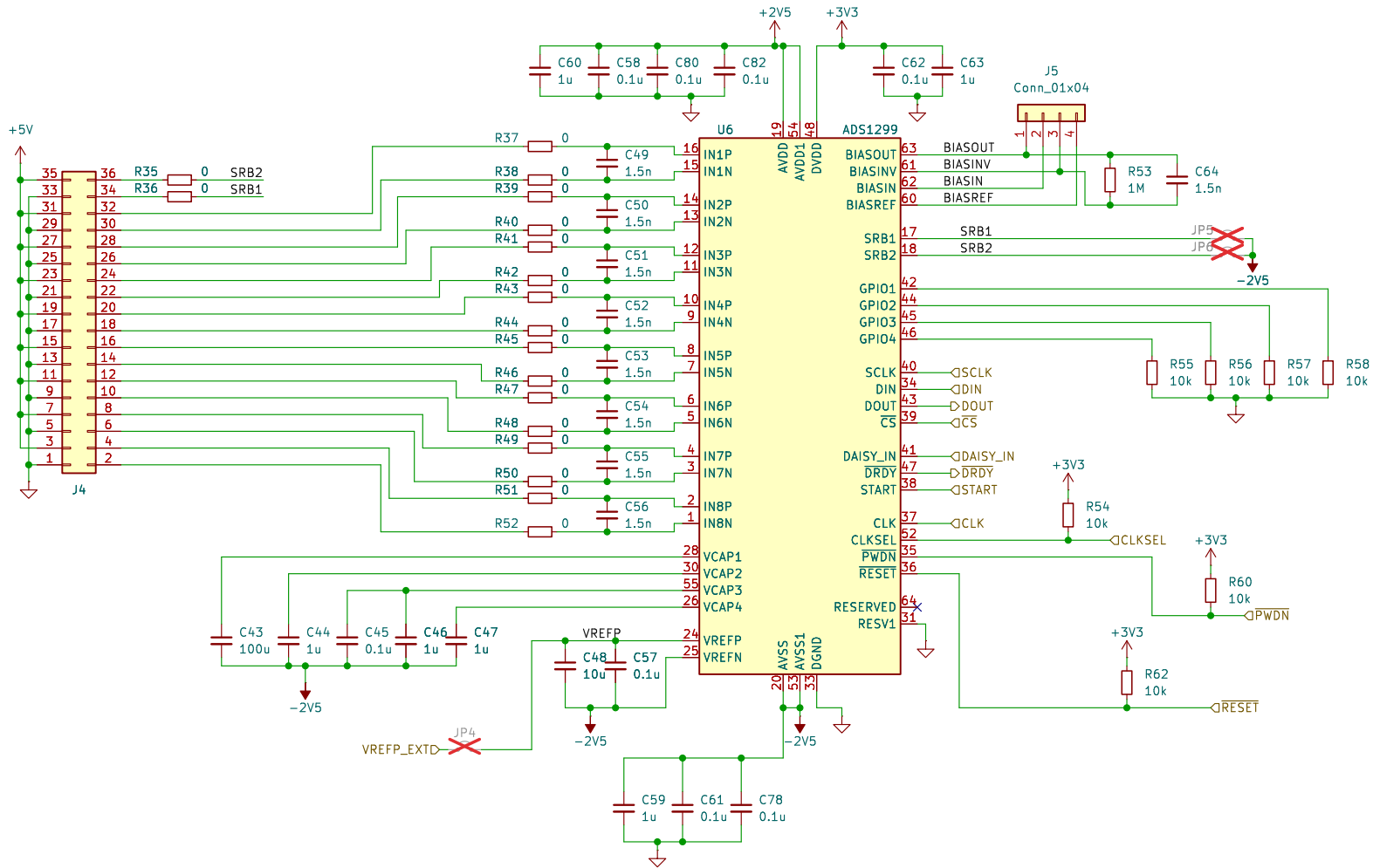

Sheet: /EEG\_amp1/  
 File: eeg\_amp.kicad\_sch

**Title: System**

Size: A4 Date: 2026-01-26  
 KiCad E.D.A. 9.0.7

Rev: 1  
 Id: 4/5

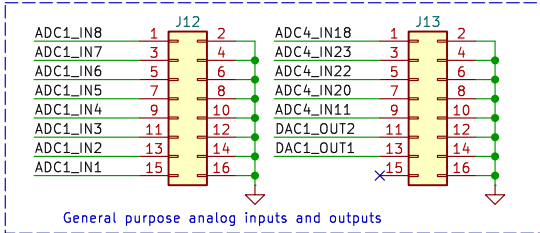
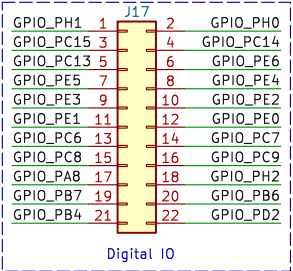
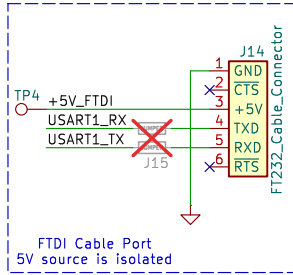
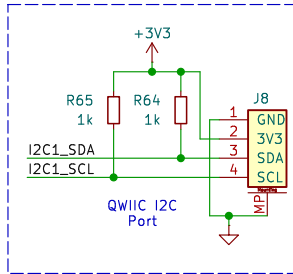
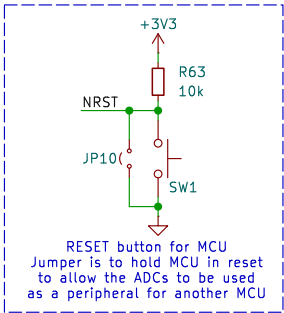
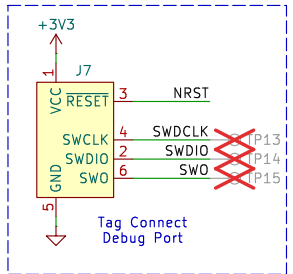
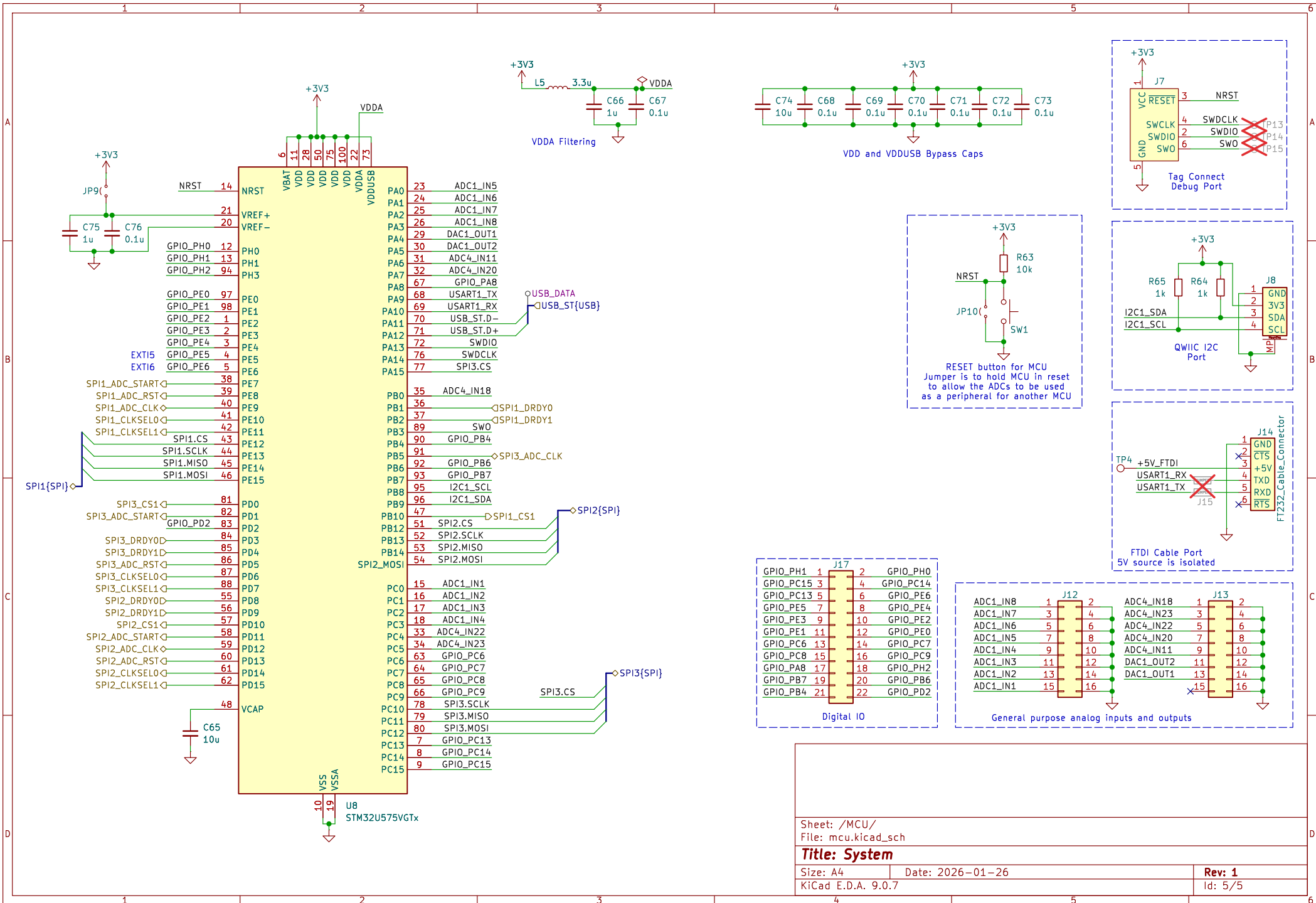

Sheet: /MCU/		Date: 2026-01-26	
File: mcu.kicad_sch		Rev: 1	
Size: A4	KitCad E.D.A. 9.0.7	Id: 5/5	