

TDA - MCU: General IO, OSC, BOOTMODE CONFIG

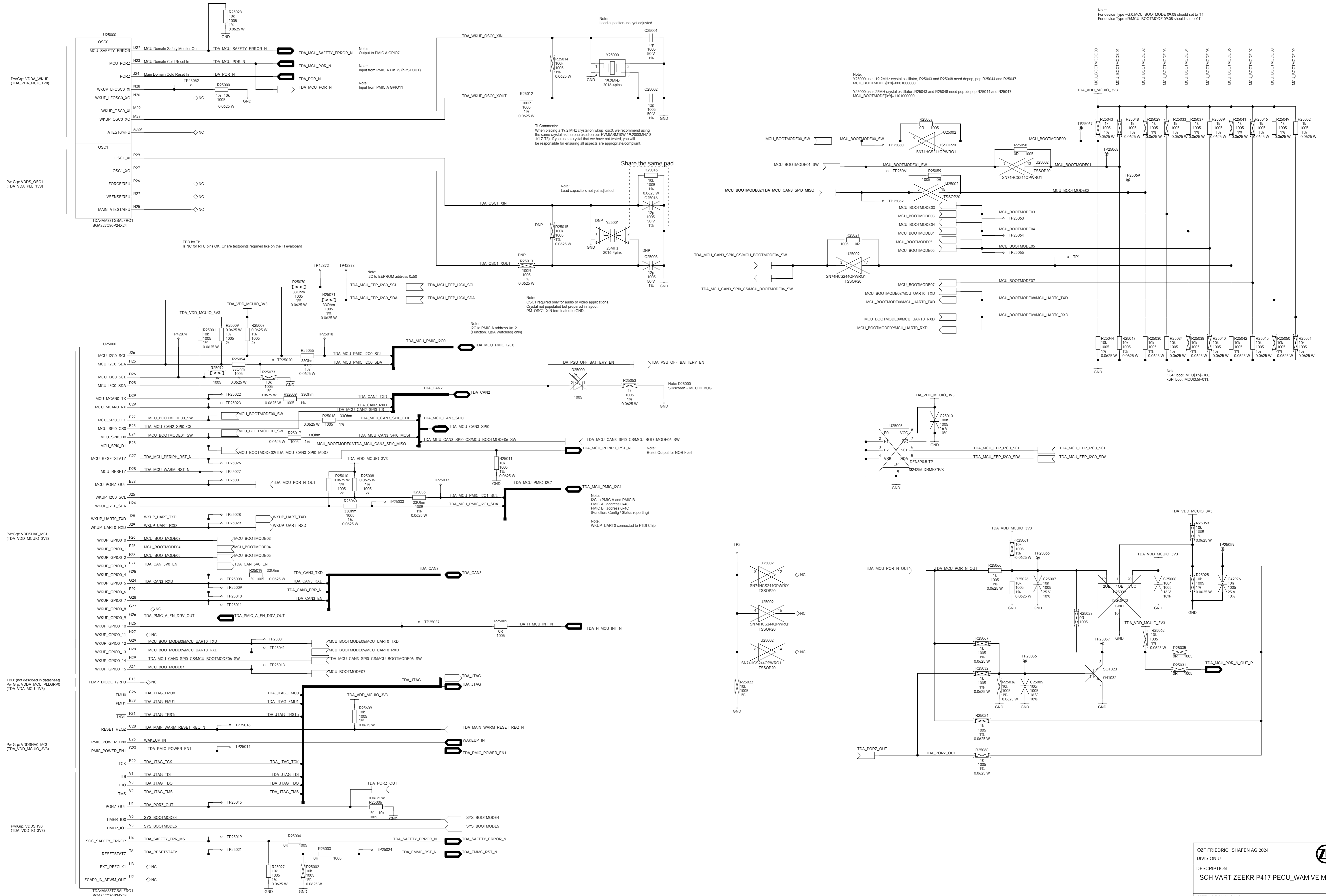

TDA - MAIN INTERFACE

TDA - EMIF (External Memory Interface) - LPDDR4

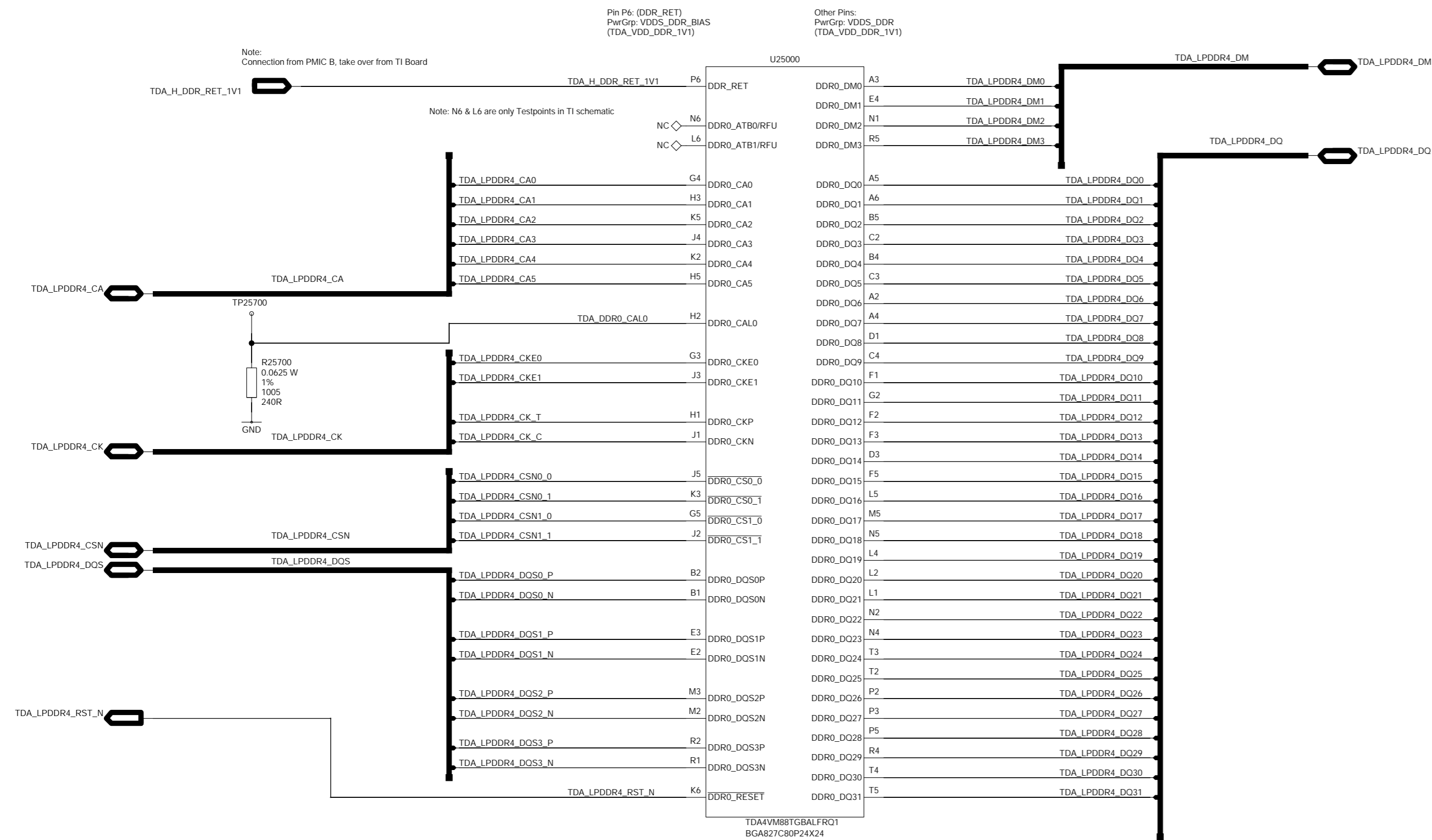

TDA - MAIN MMC Interfaces

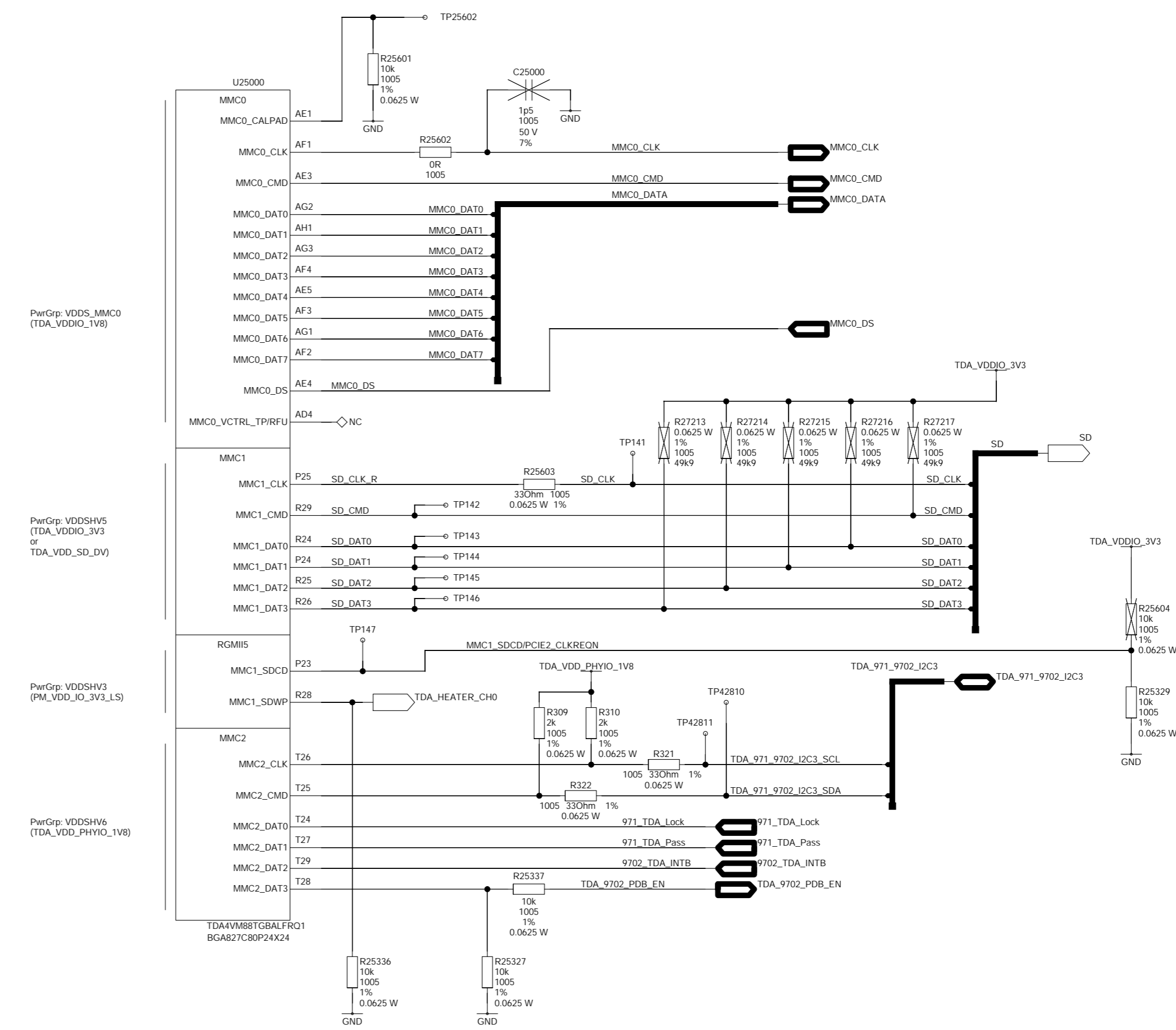

eMMC

SD Card

eMMC Flash

