

- L137 McASP/ETHERNET
- L137 SERIAL I/O
- L137 USB 2.0 PORT
- L137 USB 1.0 PORT
- L137 EMIF A
- L137 EMIF B
- L137 JTAG/CLOCKS
- L137 POWER PINS
- L137 GROUND PINS
- BOOT MODE SWITCHES
- EMIFB SDRAM
- RS232 INTERFACE
- JTAG CONNECTOR INTERFACE
- EXPANSION CONNECTOR
- POWER

1

2

3

4

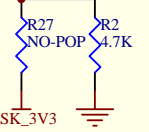
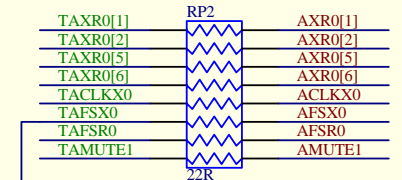
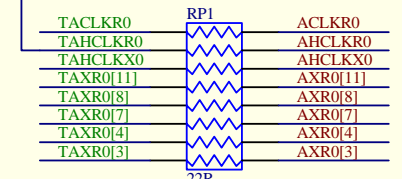
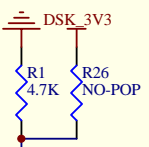

U1A

| | | | |
|---------|----|---|---------------------------------------|
| AMUTE0 | L4 | AMUTE0_RESETOUT | AXR1_0/GPIO4_0 |
| | | | AXR1_1/GPIO4_1 |
| | | | AXR1_2/GPIO4_2 |
| | | | AXR1_3/EQEP1A/GPIO4_3 |
| | | | AXR1_4/EQEP1B/GPIO4_4 |
| | | | AXR1_5/EPWM2B/GPIO4_5 |
| | | | AXR1_6/EPWM2A/GPIO4_6 |
| | | | AXR1_7/EPWM1B/GPIO4_7 |
| | | | AXR1_8/EPWM1A/GPIO4_8 |
| | | | AXR1_9/GPIO4_9 |
| | | | AXR1_10/GPIO5_10 |
| | | | AXR1_11/GPIO5_11 |
| | | | AHCLKR1/GPIO4_11 |
| | | | ACLKR1/ECAP2/APWM2/GPIO4_12 |
| | | | AFSR1/GPIO4_13 |
| | | | AHCLKX1/EPWM0B/GPIO3_14 |
| | | | ACLKX1/EPWM0A/GPIO3_15 |
| | | | AFSX1/EPWMSYNCL/EPWMSYNCO/GPIO4_10 |
| | | | AMUTE1/EHRPWM1TZ/GPIO4_14 |
| | | | AHCLKX0/AHCLKX2/USB_REFCLKIN/GPIO2_11 |
| | | | AXR0_11/AXR2_0/GPIO3_11 |
| AFSX0 | D5 | AFSX0/GPIO2_13/BOOT_10 | |
| ACLKX0 | C5 | ACLKX0/ECAP0/APWM0/GPIO2_12 | |
| AFSR0 | C4 | AFSR0/GPIO3_12 | |
| ACLKR0 | B4 | ACLKR0/ECAP1/APWM1/GPIO2_15 | |
| AXR0[6] | D7 | AXR0_6/RMIL_RXER/ACLKR2/GPIO3_6 | |
| AXR0[3] | A7 | AXR0_3/RMIL_CRS_DV/AXR2_2/GPIO3_3 | |
| AXR0[4] | B7 | AXR0_4/RMIL_RXD0/AXR2_1/GPIO3_4 | |
| AXR0[5] | C7 | AXR0_5/RMIL_RXD1/AFSX2/GPIO3_5 | |
| AXR0[2] | D8 | AXR0_2/RMIL_TXEN/AXR2_3/GPIO3_2 | |
| AXR0[0] | B8 | AXR0_0/RMIL_TXD0/AFSR2/GPIO3_0 | |
| AXR0[1] | C8 | AXR0_1/RMIL_TXD1/ACLKX2/GPIO3_1 | |
| AHCLKR0 | A4 | AHCLKR0/RMIL_MHZ_50CLK/GPIO2_14/BOOT_11 | |
| AXR0[8] | B6 | AXR0_8/MDIO_D/GPIO3_8 | |
| AXR0[7] | A6 | AXR0_7/MDIO_CLK/GPIO3_7 | |

OMAP-L137

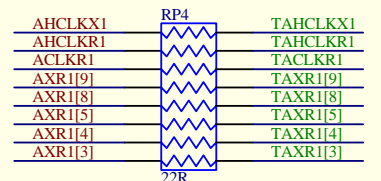
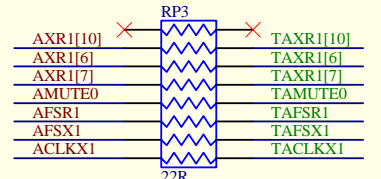
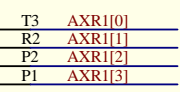

1

2

3

4

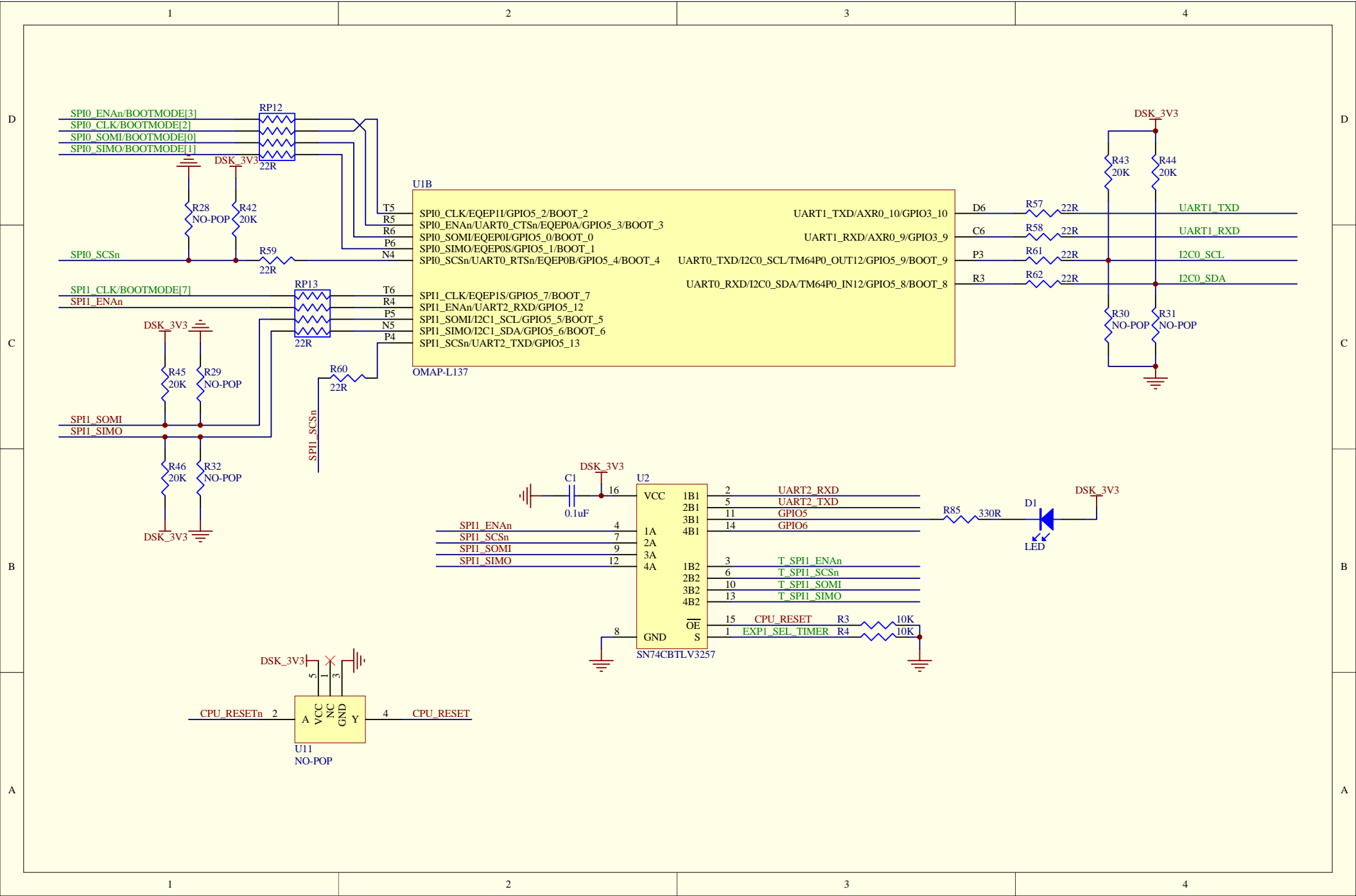

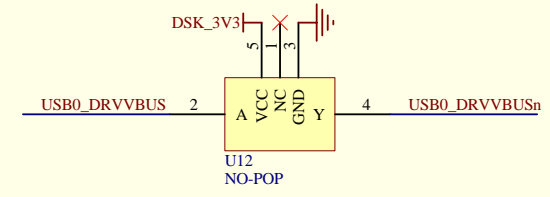
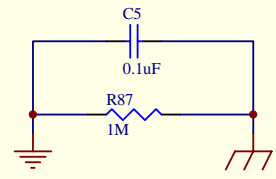
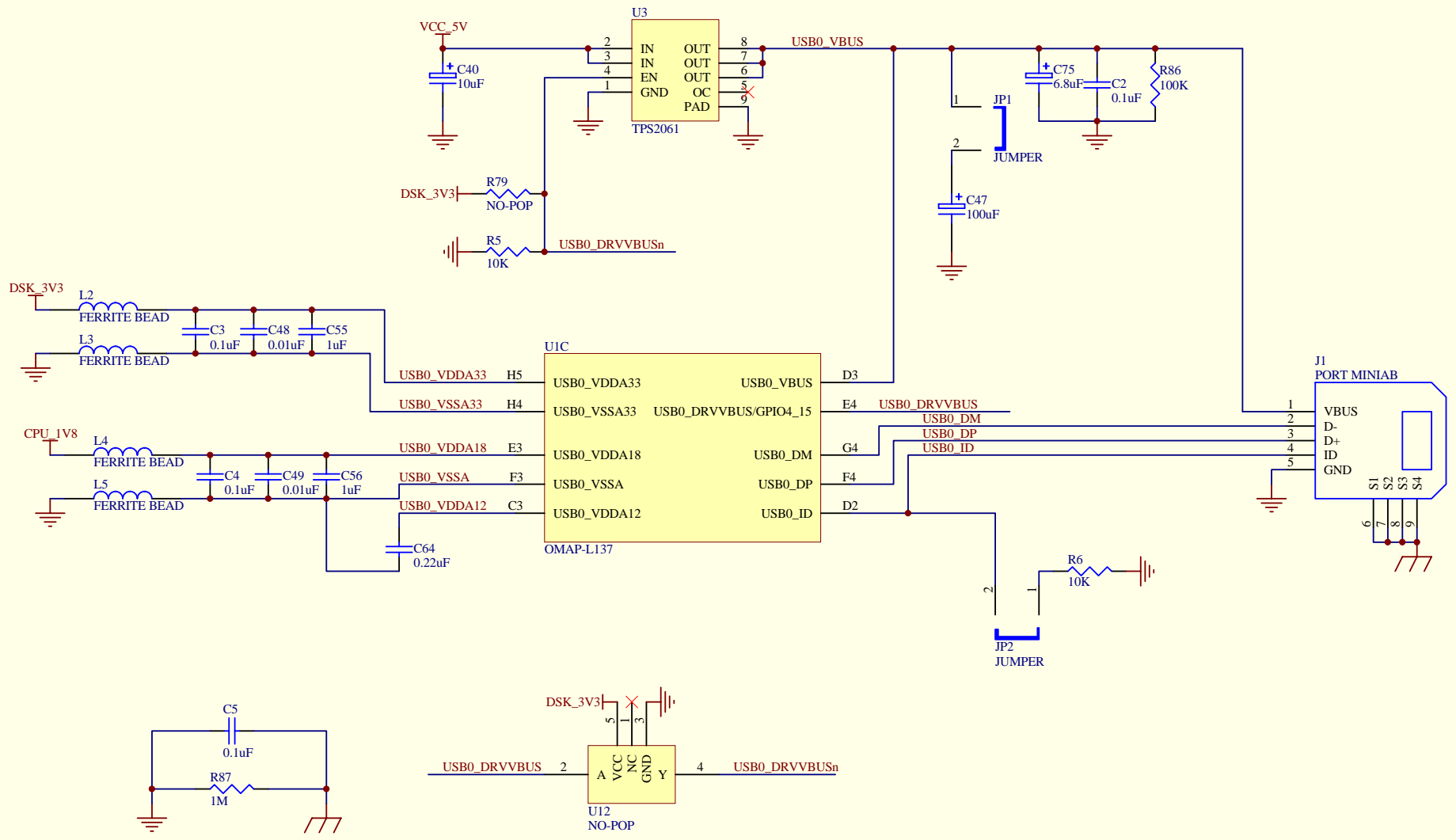

1

2

3

4

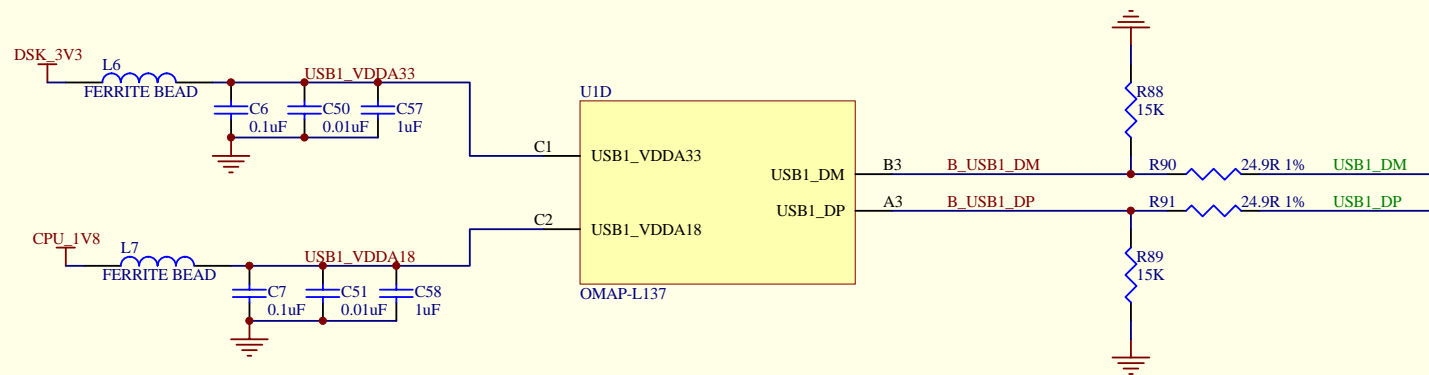

1

2

3

4

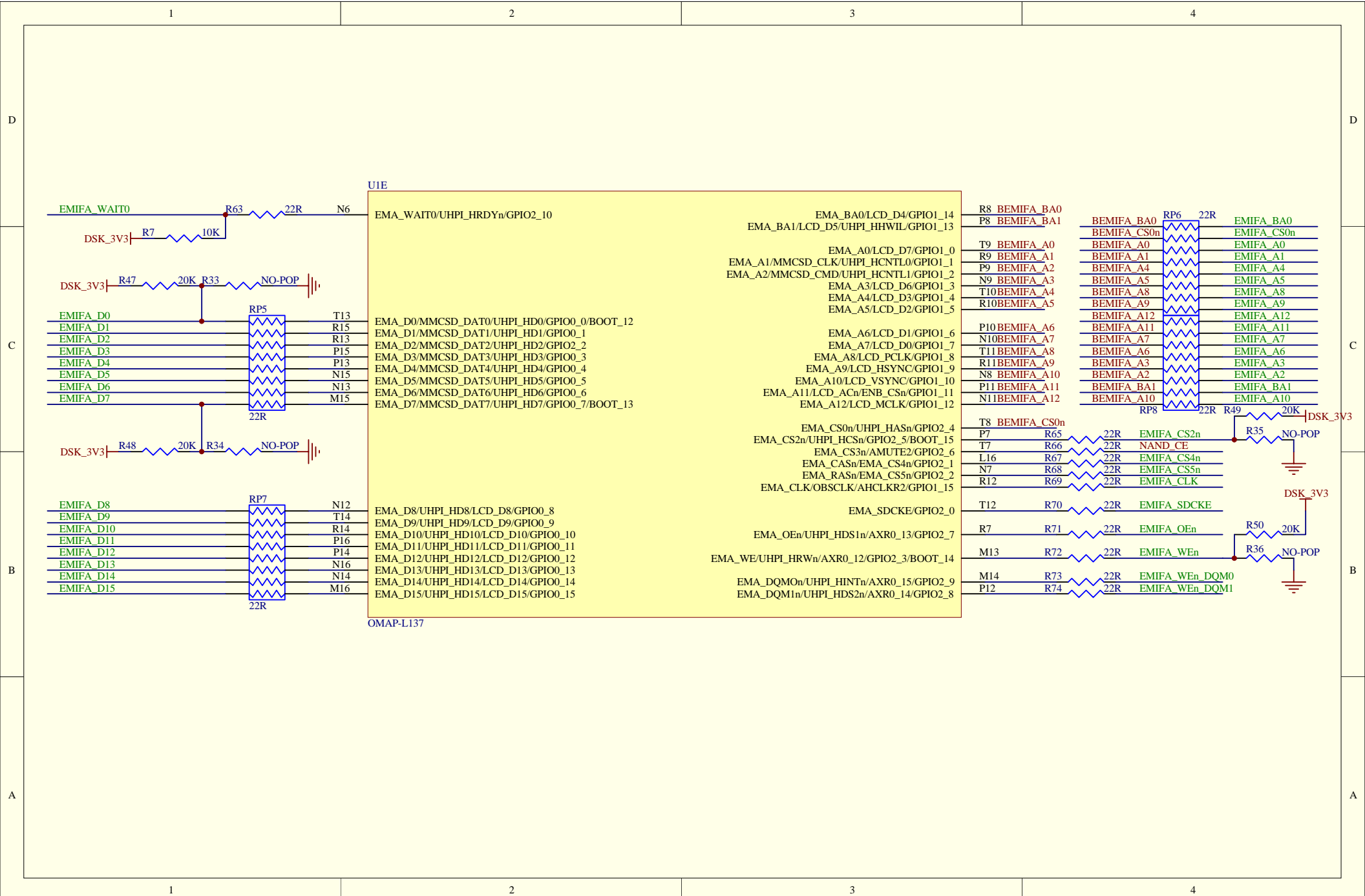

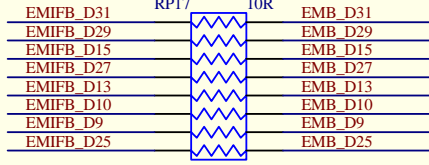
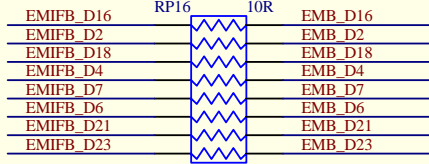
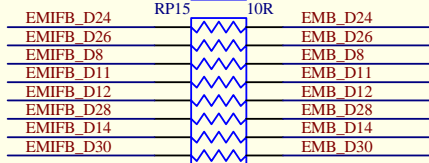
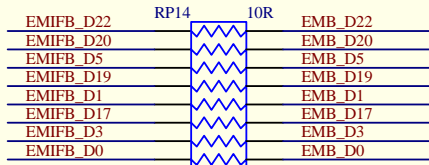

| | |
|--------|-----|
| EMB_D0 | F16 |
| EMB_D1 | G13 |
| EMB_D2 | G16 |
| EMB_D3 | H13 |
| EMB_D4 | H16 |
| EMB_D5 | J13 |
| EMB_D6 | J15 |
| EMB_D7 | J16 |

| | |
|---------|-----|
| EMB_D8 | C16 |
| EMB_D9 | D13 |
| EMB_D10 | D14 |
| EMB_D11 | D15 |
| EMB_D12 | D16 |
| EMB_D13 | E13 |
| EMB_D14 | E16 |
| EMB_D15 | F13 |

| | |
|---------|-----|
| EMB_D16 | G15 |
| EMB_D17 | H14 |
| EMB_D18 | H15 |
| EMB_D19 | J14 |
| EMB_D20 | K13 |
| EMB_D21 | K16 |
| EMB_D22 | L14 |
| EMB_D23 | L15 |

| | |
|---------|-----|
| EMB_D24 | A13 |
| EMB_D25 | B14 |
| EMB_D26 | A14 |
| EMB_D27 | E14 |
| EMB_D28 | E15 |
| EMB_D29 | F14 |
| EMB_D30 | F15 |
| EMB_D31 | G14 |

UIF

| | |
|------------------|-----------------------|
| EMB_D0/GPIO6_0 | EMB_BA0/GPIO7_1 |
| EMB_D1/GPIO6_1 | EMB_BA1/GPIO7_0 |
| EMB_D2/GPIO6_2 | |
| EMB_D3/GPIO6_3 | EMB_A0/GPIO7_2 |
| EMB_D4/GPIO6_4 | EMB_A1/GPIO7_3 |
| EMB_D5/GPIO6_5 | EMB_A2/GPIO7_4 |
| EMB_D6/GPIO6_6 | EMB_A3/GPIO7_5 |
| EMB_D7/GPIO6_7 | EMB_A4/GPIO7_6 |
| | EMB_A5/GPIO7_7 |
| | EMB_A6/GPIO7_8 |
| | EMB_A7/GPIO7_9 |
| | EMB_A8/GPIO7_10 |
| | EMB_A9/GPIO7_11 |
| | EMB_A10/GPIO7_12 |
| | EMB_A11/GPIO7_13 |
| | EMB_A12/GPIO3_13 |
| EMB_D8/GPIO6_8 | |
| EMB_D9/GPIO6_9 | |
| EMB_D10/GPIO6_10 | |
| EMB_D11/GPIO6_11 | |
| EMB_D12/GPIO6_12 | |
| EMB_D13/GPIO6_13 | |
| EMB_D14/GPIO6_14 | |
| EMB_D15/GPIO6_15 | |
| EMB_D16 | EMB_SDCKE |
| EMB_D17 | EMB_CLK |
| EMB_D18 | EMB_CS0n |
| EMB_D19 | EMB_CASn |
| EMB_D20 | EMB_RASn |
| EMB_D21 | |
| EMB_D22 | |
| EMB_D23 | |
| EMB_D24 | EMB_WE_DQM0n/GPIO5_15 |
| EMB_D25 | EMB_WE_DQM1n/GPIO5_14 |
| EMB_D26 | EMB_WE_DQM2n |
| EMB_D27 | EMB_WE_DQM3n |
| EMB_D28 | |
| EMB_D29 | |
| EMB_D30 | |
| EMB_D31 | EMB_WEn |

OMAP-L137

| | |
|-----|---------------|
| C9 | CPU_EMIFB_BA0 |
| B9 | CPU_EMIFB_BA1 |
| D10 | CPU_EMIFB_A0 |
| C10 | CPU_EMIFB_A1 |
| B10 | CPU_EMIFB_A2 |
| A10 | CPU_EMIFB_A3 |
| D11 | CPU_EMIFB_A4 |
| C11 | CPU_EMIFB_A5 |
| B11 | CPU_EMIFB_A6 |
| A11 | CPU_EMIFB_A7 |
| D12 | CPU_EMIFB_A8 |
| C12 | CPU_EMIFB_A9 |
| A9 | CPU_EMIFB_A10 |
| B12 | CPU_EMIFB_A11 |
| B15 | CPU_EMIFB_A12 |

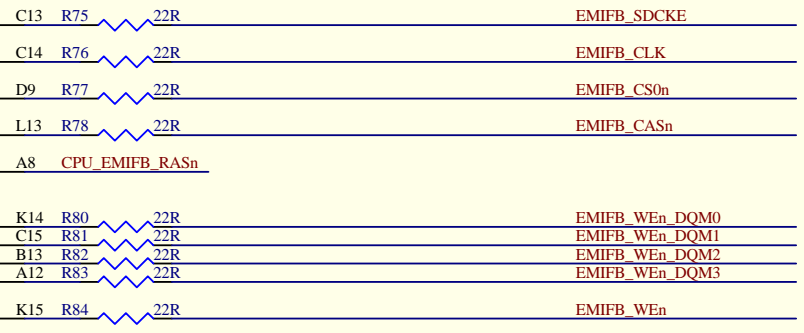

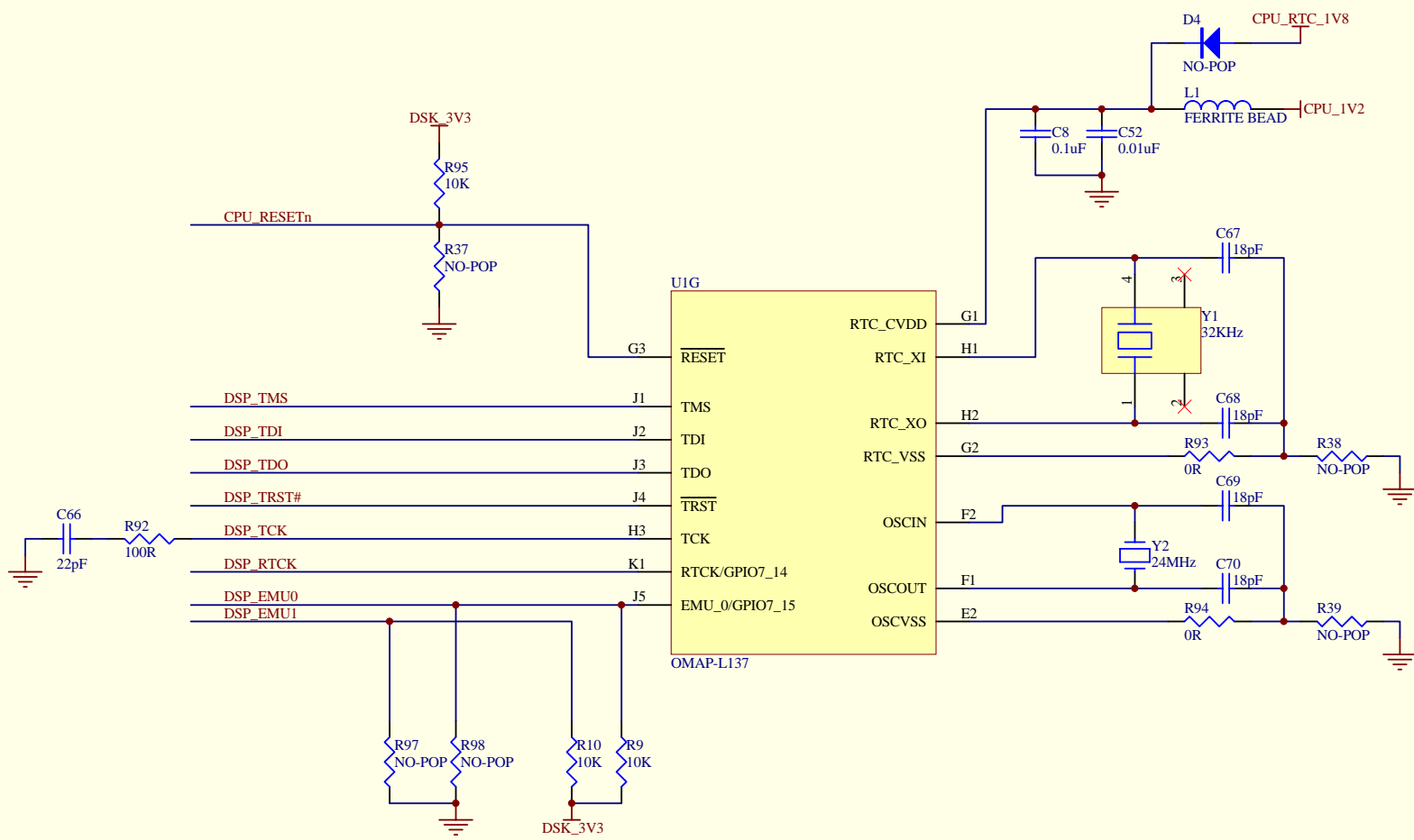

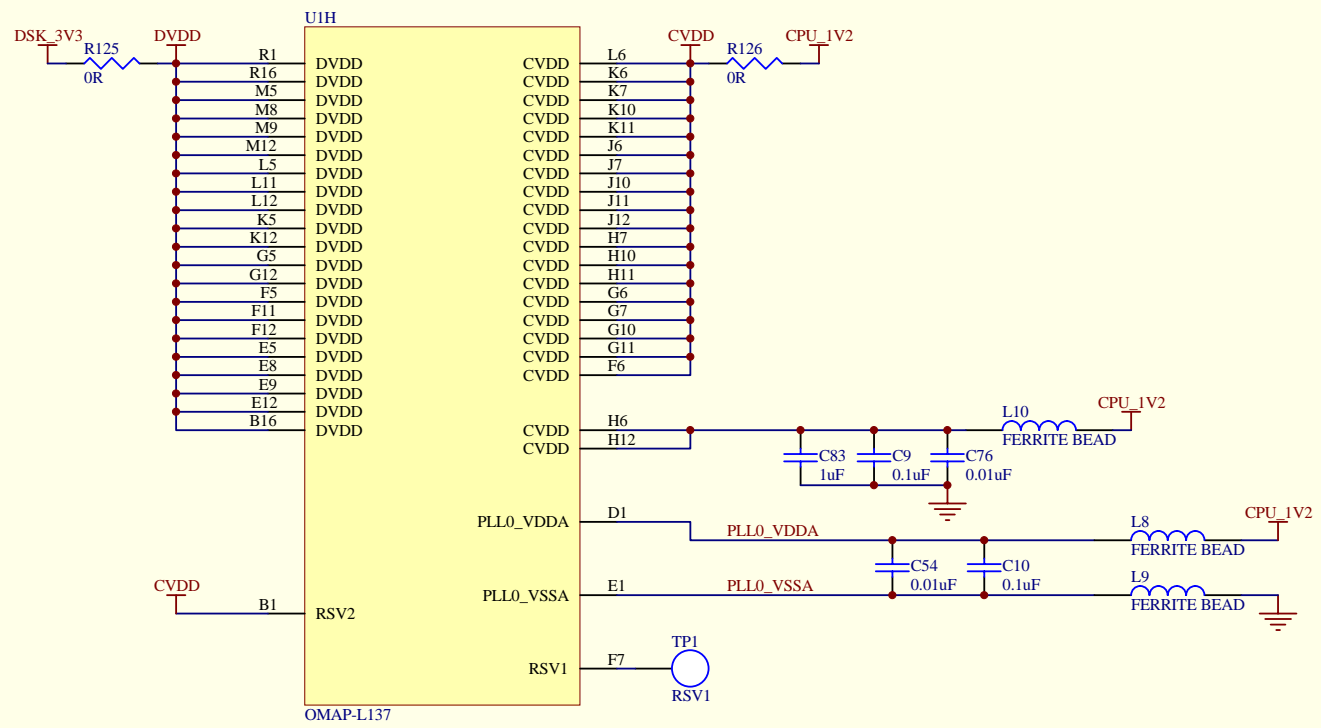

1

2

3

4

1

2

3

4

1

2

3

4

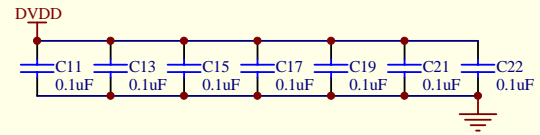
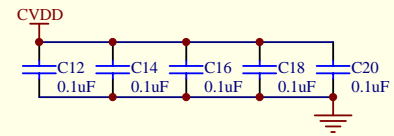
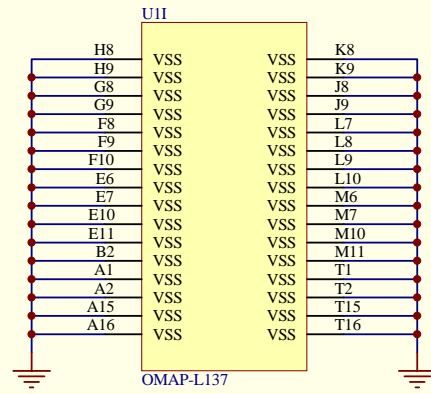

1

2

3

4

