

Shared RAM Access Considerations on OMAPL1x/C674x/AM1x

Contents

Memory Access Considerations on OMAPL1x/C674x/AM1x Devices

- Non-cacheable Writes/Stores
- Reads/Loads/Cache Fill
- Shared RAM Access Considerations on OMAPL1x/C674x/AM1x

Memory Access Considerations on OMAPL1x/C674x/AM1x Devices

Non-cacheable Writes/Stores

- "Buffered" or "fire-n-forget"
- Multiple transactions can be in flight at a time.
- Transactions progress through buffers or pipeline elements at each stage of the design
 - In DSP memory system
 - In SCR+ bridges (System Interconnect)
 - In SRAM controller
- CPU doesn't have to wait for first transaction to complete at destination before starting next write
- Latency (at least for sender) is a don't care.

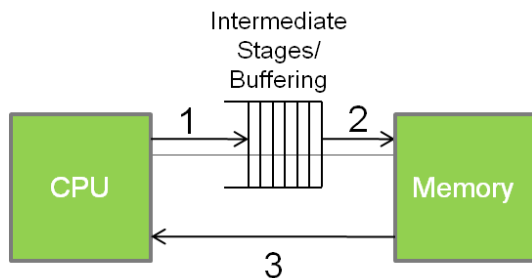

- Message can land at arbitrary later point in time.
 - CPU write throughput is limited by:
 - Throughput of #1 while buffer is empty
 - Throughput of #2 while buffer is full
 - For SRAM writes #1 Throughput == #2 Throughput

Reads/Loads/Cache Fill

- "Pended" or "Blocking"
- New Read command cannot be issued until previous read is complete.
- Latency impacts Throughput

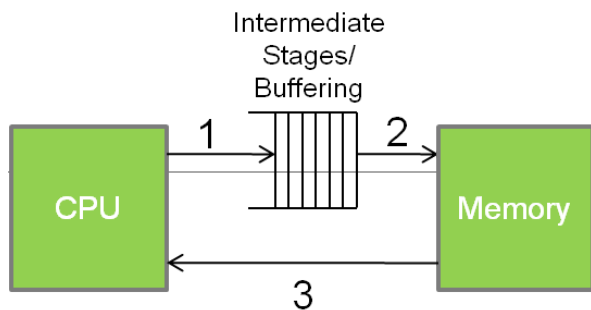

- 1 and 2 represent latency for read command through system interconnect (SCR+bridges)
- 3 represents read response data back to the initiator
- CPU read throughput is limited by:
 - Latency of #1, plus
 - Latency of #2, plus
 - Latency of #3, plus

- Number of dataphases
 - LDW = 4 Bytes = 1 phase/cycle
 - LDDW = 8 Bytes = 1 phase/cycle
 - Cache Fill = 128 Bytes = 16 phases/cycles

Shared RAM Access Considerations on OMAPL1x/C674x/AM1x

OMAPL1x/C674x/AM1x family of devices have upto 128KB of on chip memory outside the c674x DSP megamodule and ARM9 internal memory.

The following table provides the latency/throughput details for Shared RAM for accesses made by the DSP or ARM on these devices

Shared RAM Access Considerations					
	Access Size	C674x DSP		ARM9	
	Bytes	Latency (cycles)	Throughput (Bytes/Cycle)	Latency (cycles)	Throughput (Bytes/Cycle)
Writes	4	16	0.25	6	0.67
	8	16	0.5	6	1.33
Reads	4	32	0.13	27	0.15
	8	32	0.25	27	0.3
	32			31	1.03
	128	48	2.67		

Keystone=

{{

1. switchcategory:MultiCore=

- For technical support on MultiCore devices, please post your questions in the [C6000 MultiCore Forum](#)
- For questions related to the BIOS MultiCore SDK (MCSDK), please use the [BIOS Forum](#)

- For technical support on MultiCore devices, please post your questions in the [C6000 MultiCore Forum](#)
- For questions related to the BIOS MultiCore SDK (MCSDK), please use the [BIOS Forum](#)

C2000=*For technical support on the C2000 please post your questions on The C2000 Forum. Please post only comments about the article **Shared RAM Access Considerations on***

DaVinci=*For technical support on DaVincoplease post your questions on The DaVinci Forum. Please post only comments about the article **Shared RAM Access Considerations on***

MSP430=*For technical support on MSP430 please post your questions on The MSP430 Forum. Please post only comments about the article **Shared RAM Access Considerations on***

OMAP35x=*For technical support on OMAP please post your questions on The OMAP Forum. Please post only comments about the article **Shared RAM Access Considerations on***

Please post only comments related to the article **Shared RAM Access Considerations on** [OMAPL1x/C674x/AM1x](#) here.

Please post only comments related to the article **Shared RAM Access Considerations on** [OMAPL1x/C674x/AM1x](#) here.

Links



[Amplifiers & Linear](#)

[Audio](#)

[Broadband RF/IF & Digital Radio](#)

[Clocks & Timers](#)

[Data Converters](#)

[DLP & MEMS](#)

[High-Reliability](#)

[Interface](#)

[Logic](#)

[Power Management](#)

[Processors](#)

- [ARM Processors](#)
- [Digital Signal Processors \(DSP\)](#)
- [Microcontrollers \(MCU\)](#)
- [OMAP Applications Processors](#)

[Switches & Multiplexers](#)

[Temperature Sensors & Control ICs](#)

[Wireless Connectivity](#)

Retrieved from "https://processors.wiki.ti.com/index.php?title=Shared_RAM_Access_Considerations_on_OMAPL1x/C674x/AM1x&oldid=62331"

This page was last edited on 14 June 2011, at 16:17.

Content is available under [Creative Commons Attribution-ShareAlike](#) unless otherwise noted.