

FPGA\_POWER

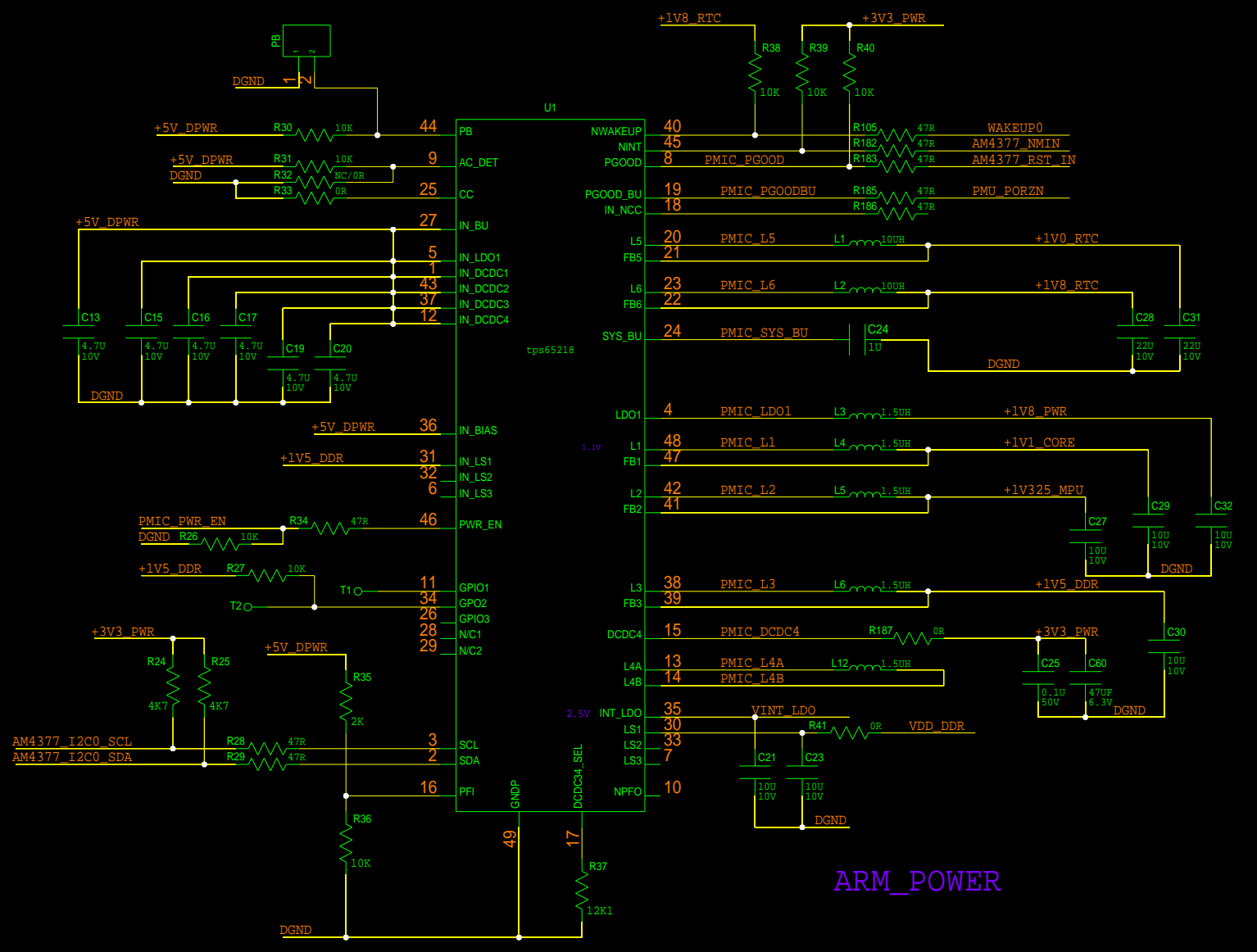

ARM\_POWER

TITLE:	DATE:
ENGINEER:	PAGE: 6

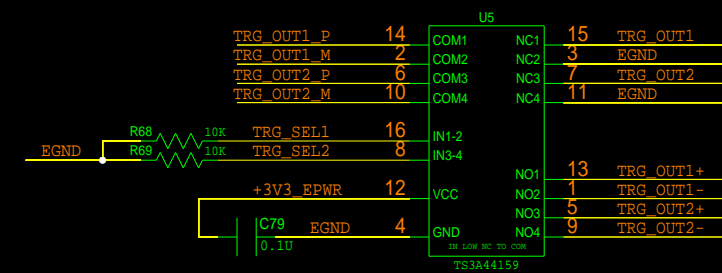
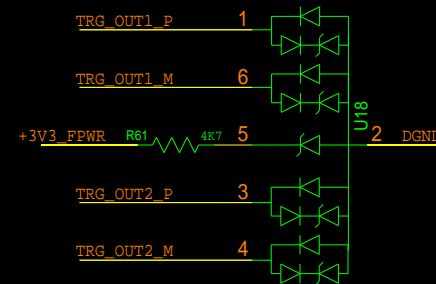
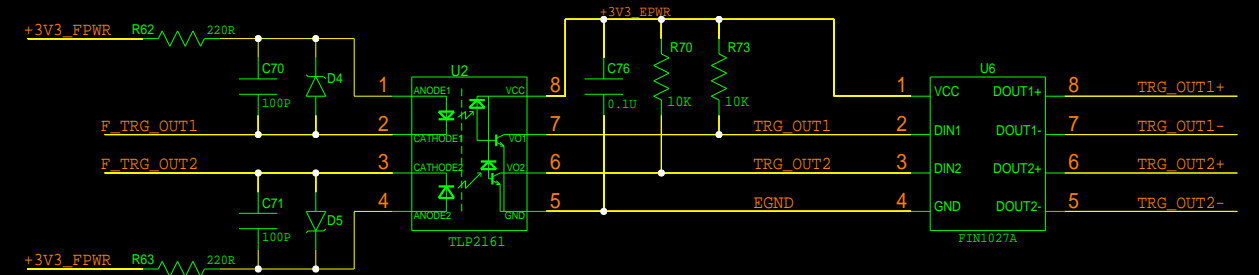
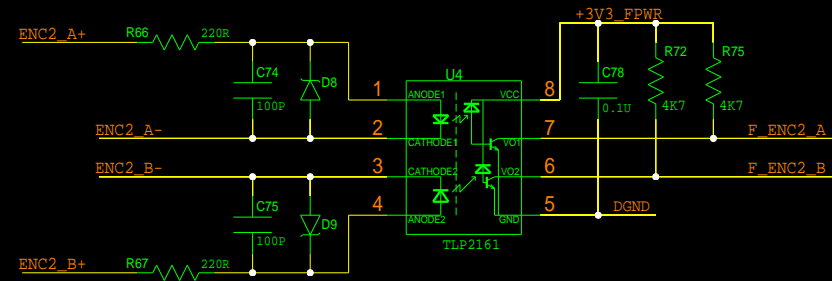
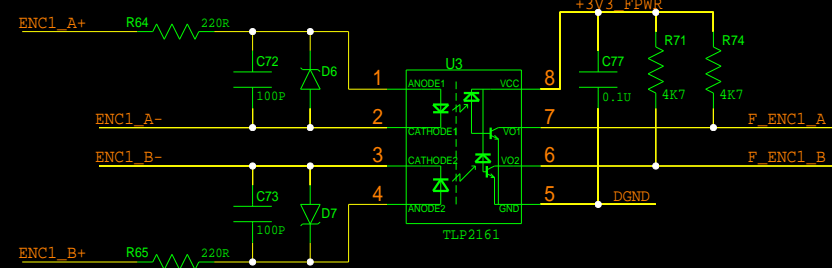
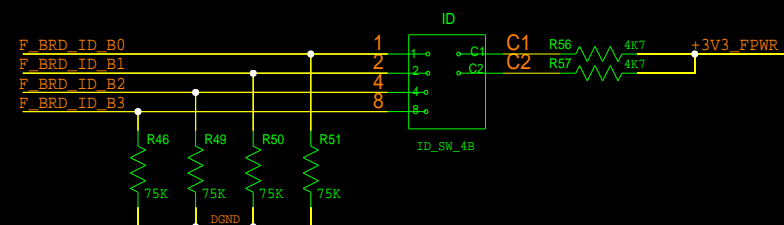
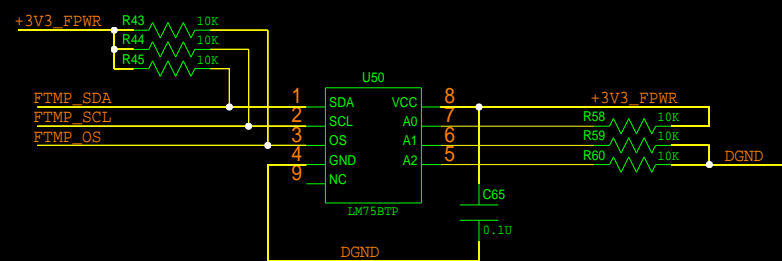
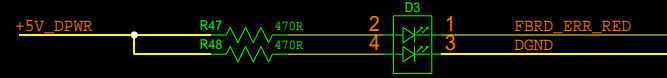
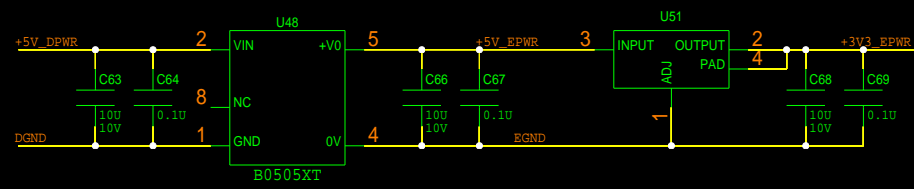
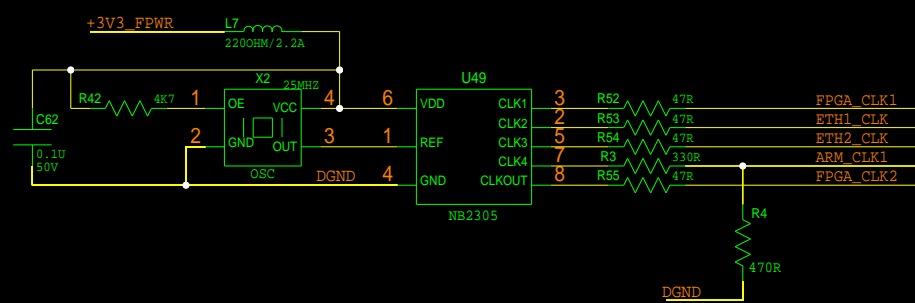

TITLE:	DATE:
ENGINEER:	PAGE: 1

+VI/O SHOULD BE DECOUPLED TO GROUND WITH AN AVERAGE OF 0.047 MF PER PIN.

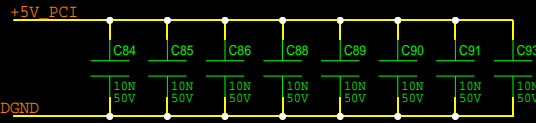
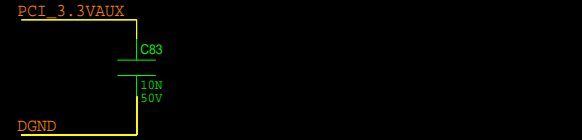
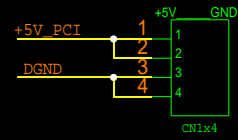
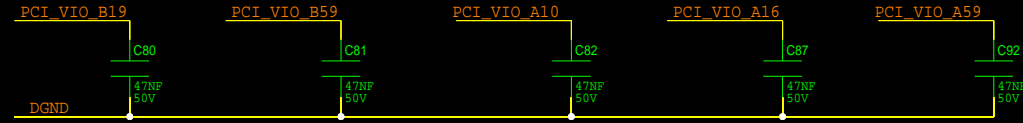

- THE DECOUPLING MUST AVERAGE AT LEAST 0.01 UF (HIGH-SPEED) PER VCC PIN
- THE TRACE LENGTH FROM PIN PAD TO CAPACITOR PAD SHALL BE NO GREATER THAN 0.25 INCHES USING A TRACE WIDTH OF AT LEAST 0.02 INCHES.

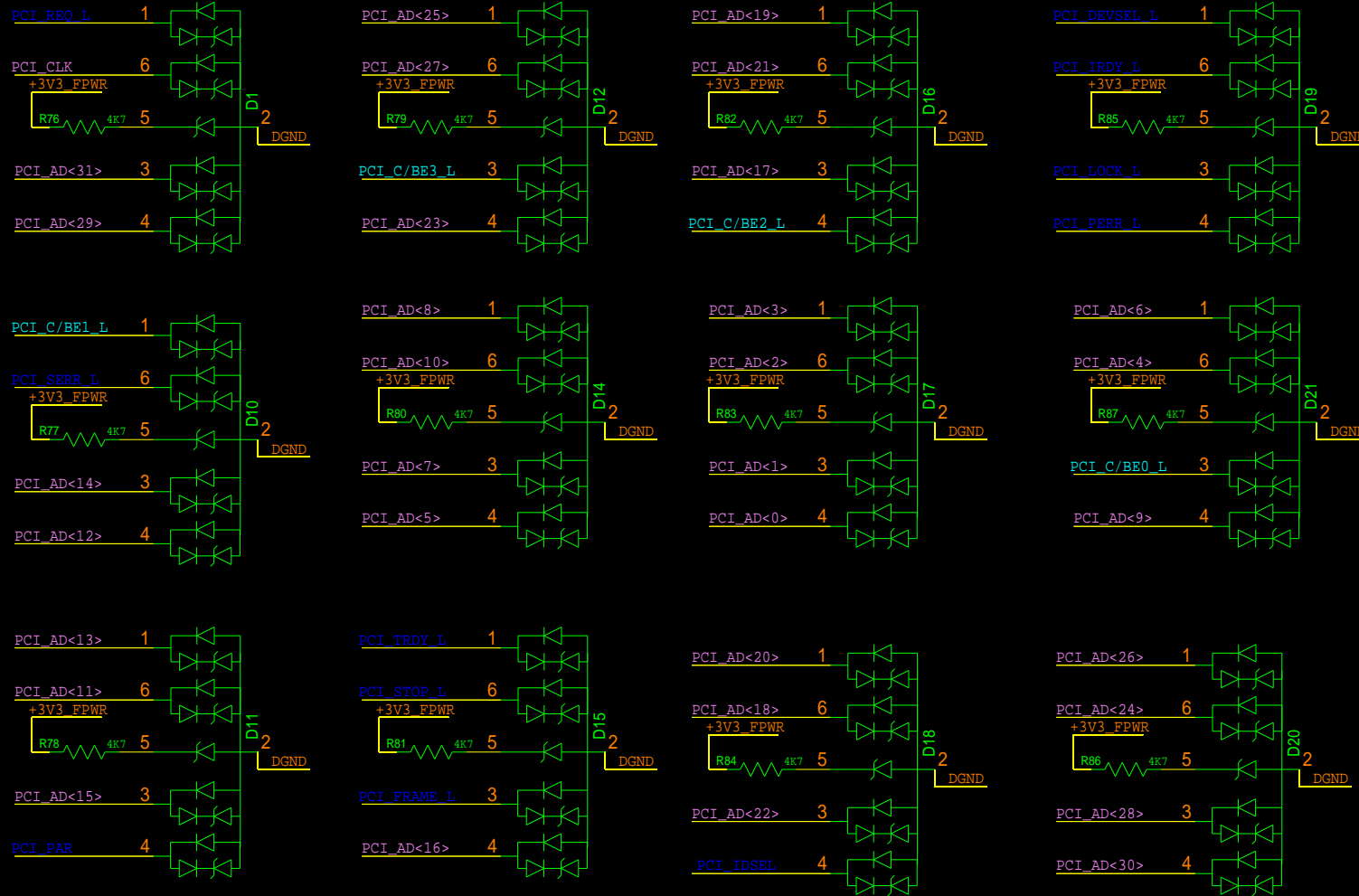

1:32-BIT INTERFACE SIGNALS ARE LIMITED TO 1.5 INCHES

2:PCI\_CLK SIGNAL IS 2.5 INCHES ; 0.1 INCHES

3:PCI SIGNAL TRACES ON THE EXPANSION BOARD SHALL BE CONTROLLED TO BE IN THE 60W -100W RANGE.

4:THE TRACE VELOCITY MUST BE BETWEEN 150 PS/INCH AND 190 PS/INCH.

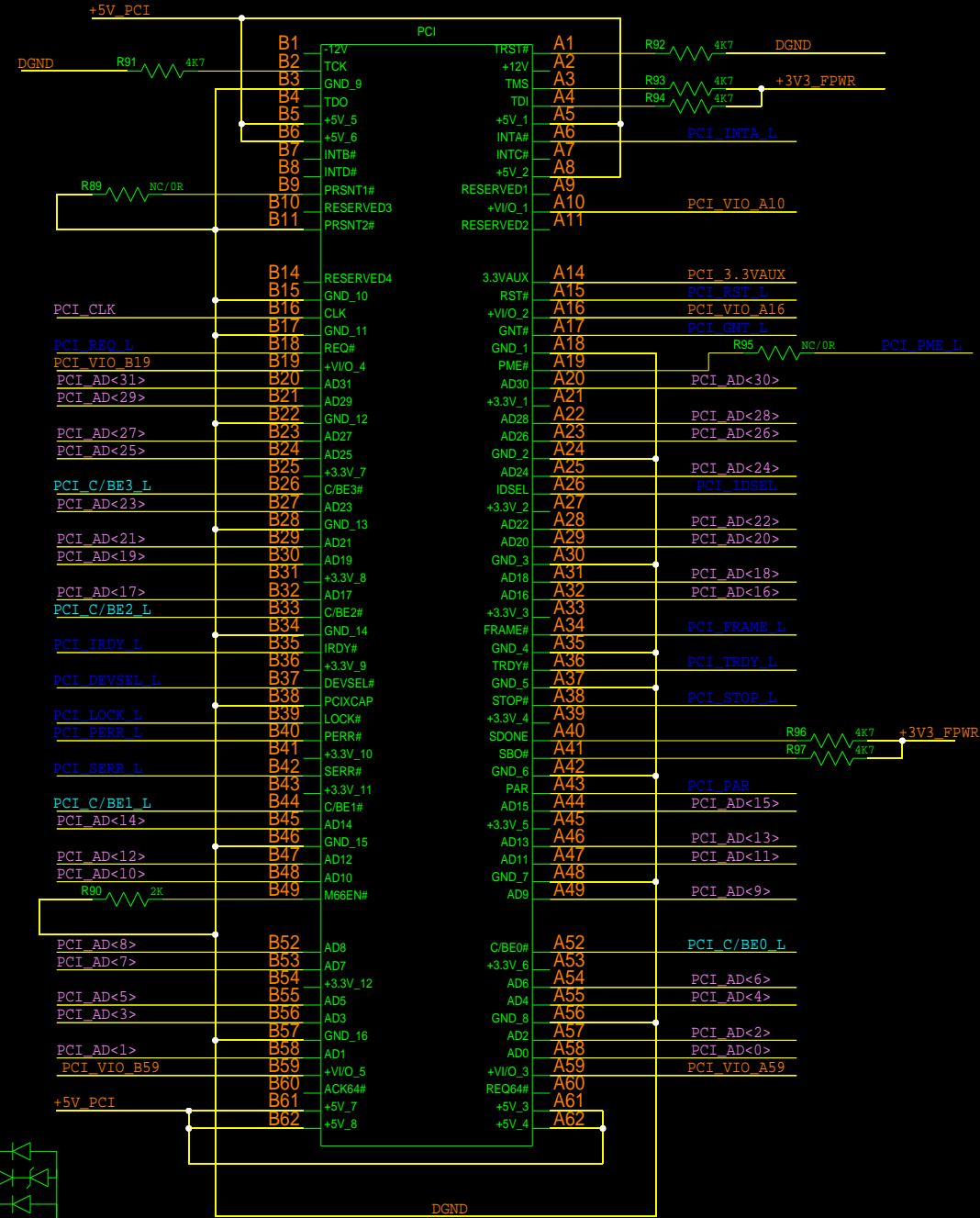

TITLE:	DATE:
ENGINEER:	PAGE: 3

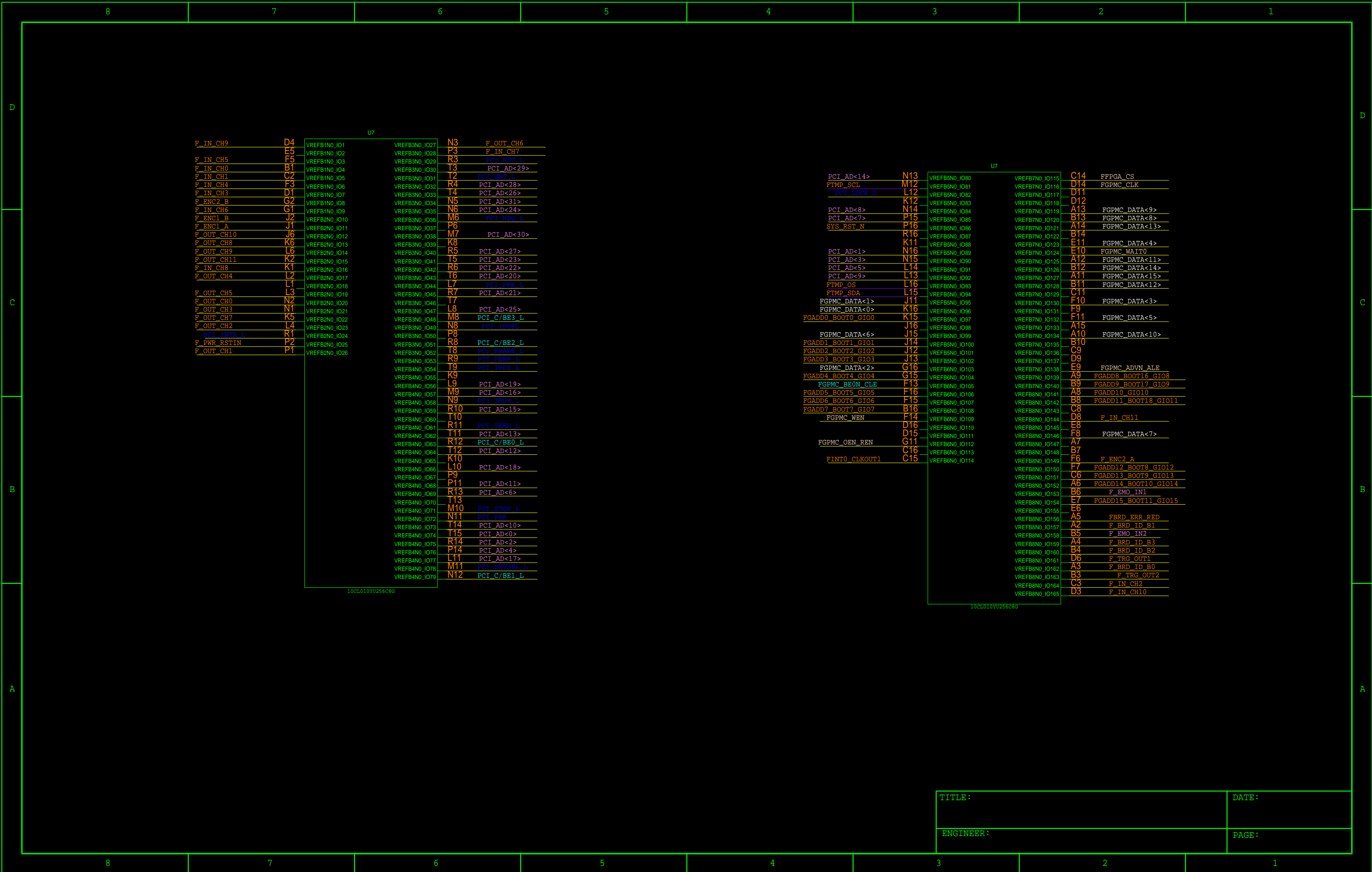

U7

F_IN_CH9	D4	VREFB1N0_IO1	VREFB3N0_IO27	N3	F_OUT_CH6
F_IN_CH5	E5	VREFB1N0_IO2	VREFB3N0_IO28	P3	F_IN_CH7
F_IN_CH0	F5	VREFB1N0_IO3	VREFB3N0_IO29	R3	PCI_RST_L
F_IN_CH1	B1	VREFB1N0_IO4	VREFB3N0_IO30	T3	PCI_AD<29>
F_IN_CH4	C2	VREFB1N0_IO5	VREFB3N0_IO31	T2	PCI_GNT_L
F_IN_CH3	F3	VREFB1N0_IO6	VREFB3N0_IO32	R4	PCI_AD<28>
F_ENC2_B	D1	VREFB1N0_IO7	VREFB3N0_IO33	T4	PCI_AD<26>
F_IN_CH6	G1	VREFB1N0_IO8	VREFB3N0_IO34	N5	PCI_AD<31>
F_ENC1_B	J2	VREFB1N0_IO9	VREFB3N0_IO35	N6	PCI_AD<24>
F_ENC1_A	J1	VREFB2N0_IO10	VREFB3N0_IO36	M6	PCI_RE0_L
F_OUT_CH10	J6	VREFB2N0_IO11	VREFB3N0_IO37	P6	PCI_AD<30>
F_OUT_CH8	K6	VREFB2N0_IO12	VREFB3N0_IO38	M7	PCI_AD<30>
F_OUT_CH9	L6	VREFB2N0_IO13	VREFB3N0_IO39	K8	PCI_AD<27>
F_OUT_CH11	K2	VREFB2N0_IO14	VREFB3N0_IO40	R5	PCI_AD<27>
F_IN_CH8	K1	VREFB2N0_IO15	VREFB3N0_IO41	T5	PCI_AD<23>
F_OUT_CH4	L2	VREFB2N0_IO16	VREFB3N0_IO42	R6	PCI_AD<22>
F_OUT_CH5	L3	VREFB2N0_IO17	VREFB3N0_IO43	T6	PCI_AD<20>
F_OUT_CH0	N2	VREFB2N0_IO18	VREFB3N0_IO44	L7	PCI_FME_L
F_OUT_CH3	N1	VREFB2N0_IO19	VREFB3N0_IO45	R7	PCI_AD<21>
F_OUT_CH7	K5	VREFB2N0_IO20	VREFB3N0_IO46	T7	PCI_AD<25>
F_OUT_CH2	L4	VREFB2N0_IO21	VREFB3N0_IO47	L8	PCI_AD<25>
PCI_INTA_L	R1	VREFB2N0_IO22	VREFB3N0_IO48	M8	PCI_C/BE3_L
F_BWR_RSTIN	P2	VREFB2N0_IO23	VREFB3N0_IO49	N8	PCI_IDSEL
F_OUT_CH1	P1	VREFB2N0_IO24	VREFB3N0_IO50	P8	PCI_C/BE2_L
		VREFB2N0_IO25	VREFB3N0_IO51	R8	PCI_C/BE2_L
		VREFB2N0_IO26	VREFB3N0_IO52	T8	PCI_FRAME_L
			VREFB4N0_IO53	R9	PCI_PERR_L
			VREFB4N0_IO54	T9	PCI_TRDY_L
			VREFB4N0_IO55	K9	PCI_IRDY_L
			VREFB4N0_IO56	L9	PCI_AD<19>
			VREFB4N0_IO57	M9	PCI_AD<16>
			VREFB4N0_IO58	N9	PCI_TRDY_L
			VREFB4N0_IO59	R10	PCI_AD<15>
			VREFB4N0_IO60	T10	PCI_AD<15>
			VREFB4N0_IO61	R11	PCI_SBRR_L
			VREFB4N0_IO62	T11	PCI_AD<13>
			VREFB4N0_IO63	R12	PCI_C/BE0_L
			VREFB4N0_IO64	T12	PCI_AD<12>
			VREFB4N0_IO65	K10	PCI_AD<12>
			VREFB4N0_IO66	L10	PCI_AD<18>
			VREFB4N0_IO67	P9	PCI_AD<18>
			VREFB4N0_IO68	P11	PCI_AD<11>
			VREFB4N0_IO69	R13	PCI_AD<6>
			VREFB4N0_IO70	T13	PCI_AD<6>
			VREFB4N0_IO71	M10	PCI_STOP_L
			VREFB4N0_IO72	N11	PCI_BAR
			VREFB4N0_IO73	T14	PCI_AD<10>
			VREFB4N0_IO74	T15	PCI_AD<0>
			VREFB4N0_IO75	R14	PCI_AD<2>
			VREFB4N0_IO76	P14	PCI_AD<4>
			VREFB4N0_IO77	L11	PCI_AD<17>
			VREFB4N0_IO78	M11	PCI_DEVSEL_L
			VREFB4N0_IO79	N12	PCI_C/BE1_L

10CL010YU256C8G

U7

PCI_AD<14>	N13	VREFB8N0_IO80	VREFB7N0_IO115	C14	FFPGA_CS
FTMP_SCL	M12	VREFB8N0_IO81	VREFB7N0_IO116	D14	FGPMC_CLK
PCI_LOCK_L	L12	VREFB8N0_IO82	VREFB7N0_IO117	D11	
	K12	VREFB8N0_IO83	VREFB7N0_IO118	D12	
PCI_AD<8>	N14	VREFB8N0_IO84	VREFB7N0_IO119	A13	FGPMC_DATA<9>
PCI_AD<7>	P15	VREFB8N0_IO85	VREFB7N0_IO120	B13	FGPMC_DATA<8>
SYS_RST_N	P16	VREFB8N0_IO86	VREFB7N0_IO121	A14	FGPMC_DATA<13>
	R16	VREFB8N0_IO87	VREFB7N0_IO122	B14	
	K11	VREFB8N0_IO88	VREFB7N0_IO123	E11	FGPMC_DATA<4>
PCI_AD<1>	N16	VREFB8N0_IO89	VREFB7N0_IO124	E10	FGPMC_WAIT0
PCI_AD<3>	N15	VREFB8N0_IO90	VREFB7N0_IO125	A12	FGPMC_DATA<11>
PCI_AD<5>	L14	VREFB8N0_IO91	VREFB7N0_IO126	B12	FGPMC_DATA<14>
PCI_AD<9>	L13	VREFB8N0_IO92	VREFB7N0_IO127	A11	FGPMC_DATA<15>
FTMP_OS	L16	VREFB8N0_IO93	VREFB7N0_IO128	B11	FGPMC_DATA<12>
FTMP_SDA	L15	VREFB8N0_IO94	VREFB7N0_IO129	C11	
FGPMC_DATA<1>	J11	VREFB8N0_IO95	VREFB7N0_IO130	F10	FGPMC_DATA<3>
FGPMC_DATA<0>	K16	VREFB8N0_IO96	VREFB7N0_IO131	F9	
FGADD0_BOOT0_GIO0	K15	VREFB8N0_IO97	VREFB7N0_IO132	F11	FGPMC_DATA<5>
	J16	VREFB8N0_IO98	VREFB7N0_IO133	A15	
FGPMC_DATA<6>	J15	VREFB8N0_IO99	VREFB7N0_IO134	A10	FGPMC_DATA<10>
FGADD1_BOOT1_GIO1	J14	VREFB8N0_IO100	VREFB7N0_IO135	B10	
FGADD2_BOOT2_GIO2	J14	VREFB8N0_IO101	VREFB7N0_IO136	C9	
FGADD3_BOOT3_GIO3	J13	VREFB8N0_IO102	VREFB7N0_IO137	D9	
FGPMC_DATA<2>	G16	VREFB8N0_IO103	VREFB7N0_IO138	E9	FGPMC_ADVN_ALE
FGADD4_BOOT4_GIO4	G15	VREFB8N0_IO104	VREFB7N0_IO139	A9	FGADD8_BOOT16_GIO8
FGPMC_BE0N_CLE	F13	VREFB8N0_IO105	VREFB7N0_IO140	B9	FGADD9_BOOT17_GIO9
FGADD5_BOOT5_GIO5	F16	VREFB8N0_IO106	VREFB8N0_IO141	A8	FGADD10_GIO10
FGADD6_BOOT6_GIO6	F15	VREFB8N0_IO107	VREFB8N0_IO142	B8	FGADD11_BOOT18_GIO11
FGADD7_BOOT7_GIO7	B16	VREFB8N0_IO108	VREFB8N0_IO143	C8	
FGPMC_WEN	F14	VREFB8N0_IO109	VREFB8N0_IO144	D8	F_IN_CH11
	D16	VREFB8N0_IO110	VREFB8N0_IO145	E8	
	D15	VREFB8N0_IO111	VREFB8N0_IO146	F8	FGPMC_DATA<7>
FGPMC_OEN_REN	G11	VREFB8N0_IO112	VREFB8N0_IO147	A7	
	C16	VREFB8N0_IO113	VREFB8N0_IO148	B7	
FINT0_CLKOUT1	C15	VREFB8N0_IO114	VREFB8N0_IO149	F6	F_ENC2_A
			VREFB8N0_IO150	F7	FGADD12_BOOT8_GIO12
			VREFB8N0_IO151	C6	FGADD13_BOOT9_GIO13
			VREFB8N0_IO152	A6	FGADD14_BOOT10_GIO14
			VREFB8N0_IO153	B6	F_EMO_IN1
			VREFB8N0_IO154	E7	FGADD15_BOOT11_GIO15
			VREFB8N0_IO155	E6	
			VREFB8N0_IO156	A5	FBRD_ERR_RED
			VREFB8N0_IO157	A2	F_BRD_ID_B1
			VREFB8N0_IO158	B5	F_EMO_IN2
			VREFB8N0_IO159	A4	F_BRD_ID_B3
			VREFB8N0_IO160	B4	F_BRD_ID_B2
			VREFB8N0_IO161	D6	F_TRG_OUT1
			VREFB8N0_IO162	A3	F_BRD_ID_B0
			VREFB8N0_IO163	B3	F_TRG_OUT2
			VREFB8N0_IO164	C3	F_IN_CH2
			VREFB8N0_IO165	D3	F_IN_CH10

10CL010YU256C8G

TITLE :	DATE :
ENGINEER :	PAGE :

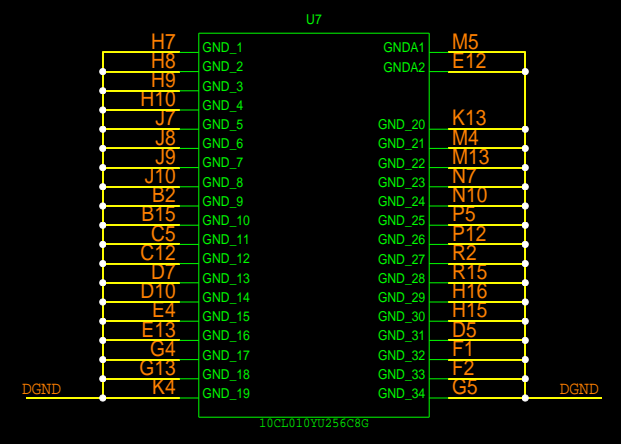
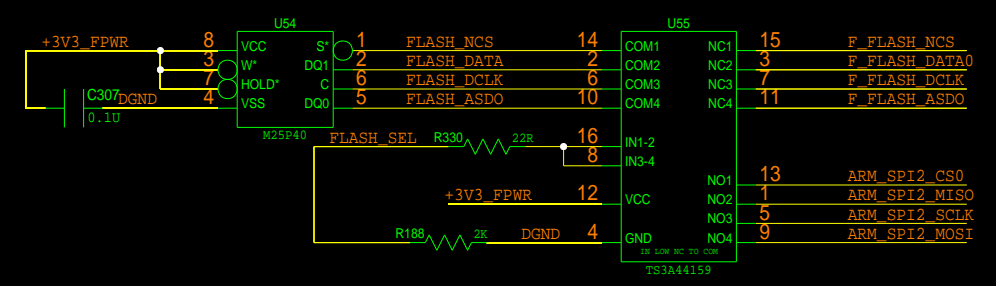
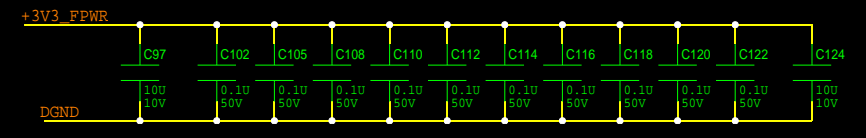
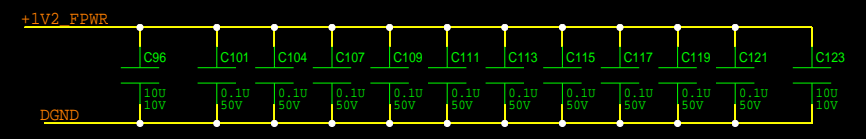
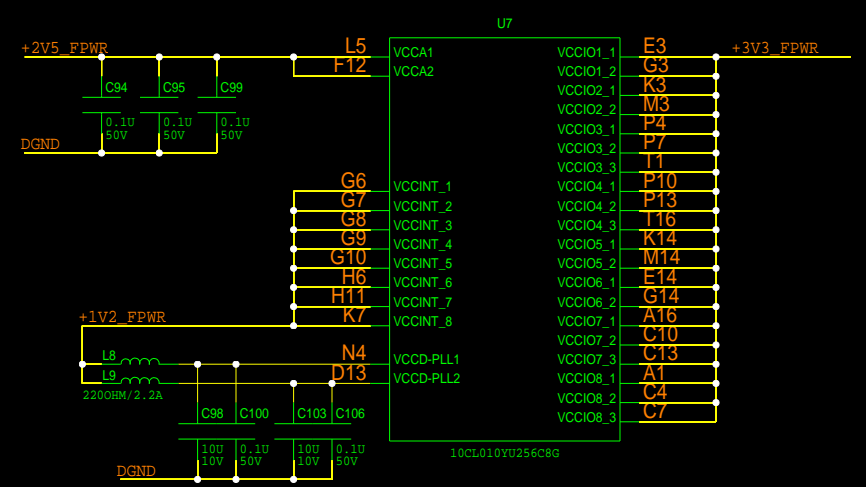
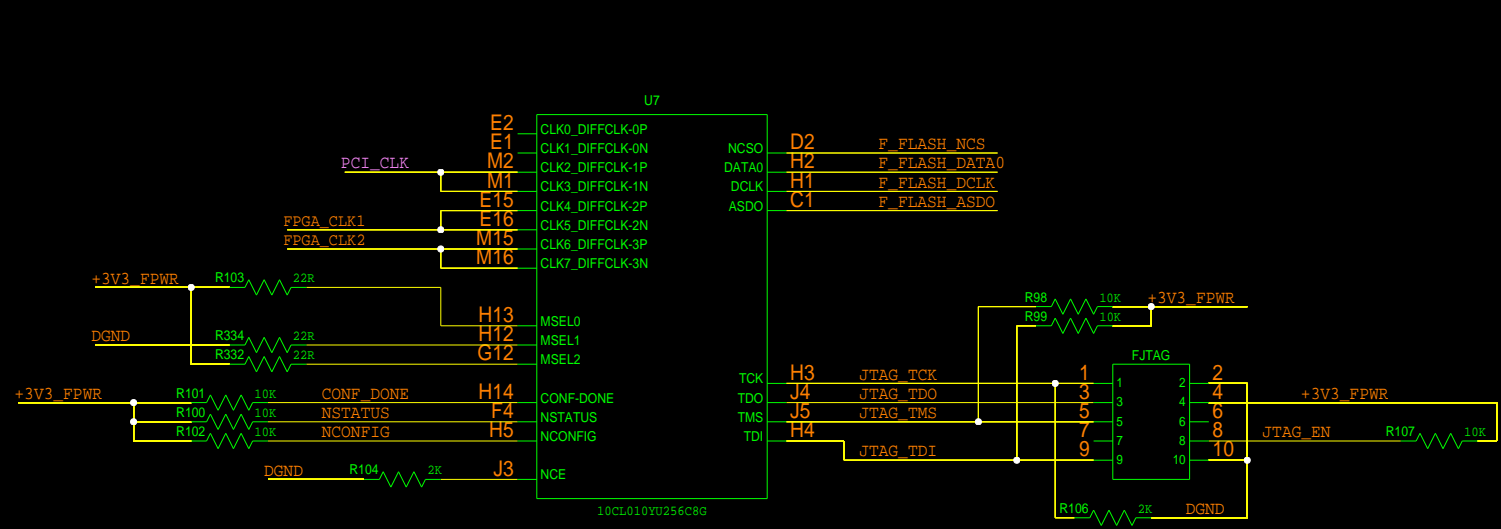

TITLE:	DATE:
ENGINEER:	PAGE:

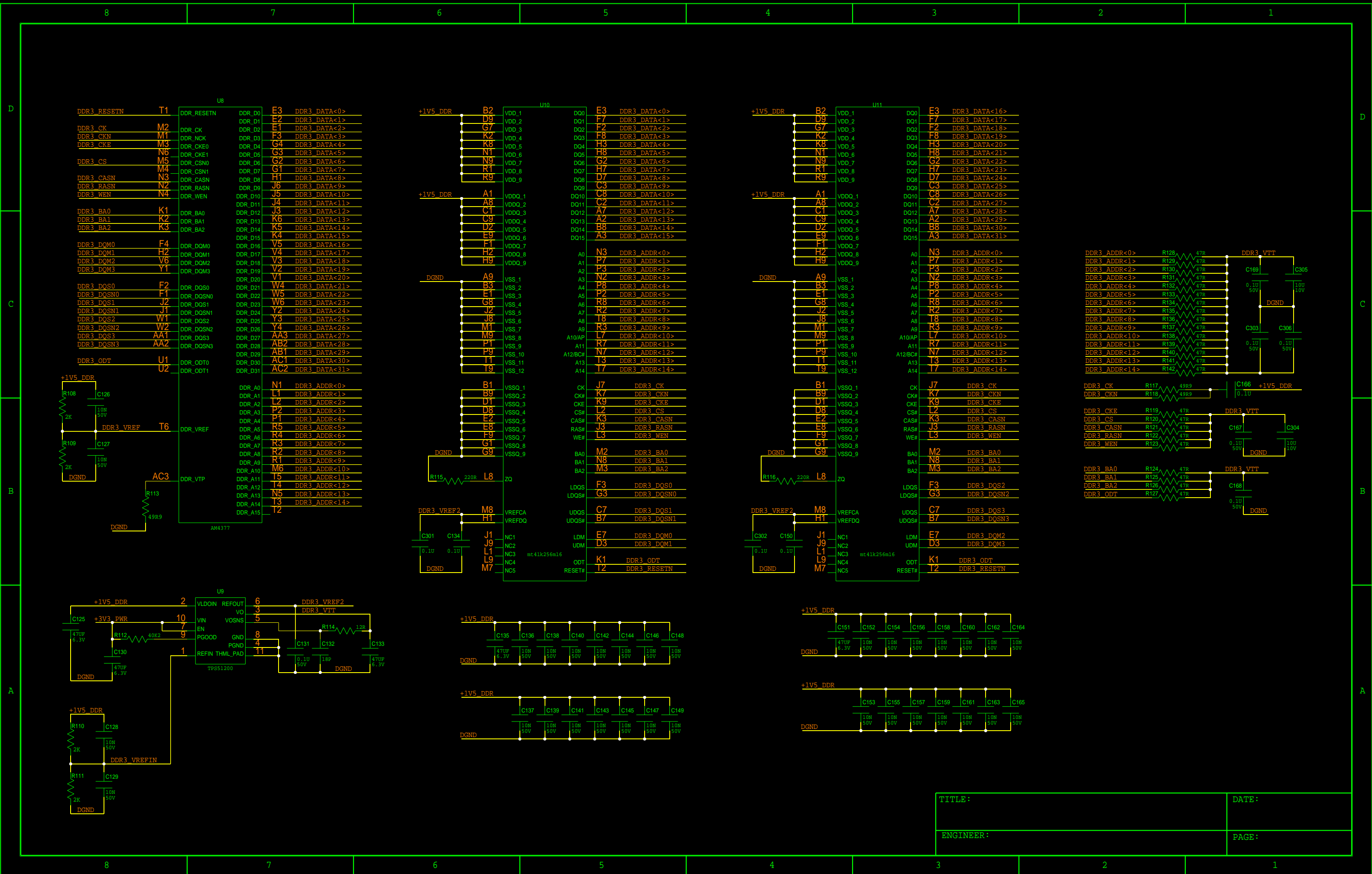

TITLE:	DATE:
ENGINEER:	PAGE:

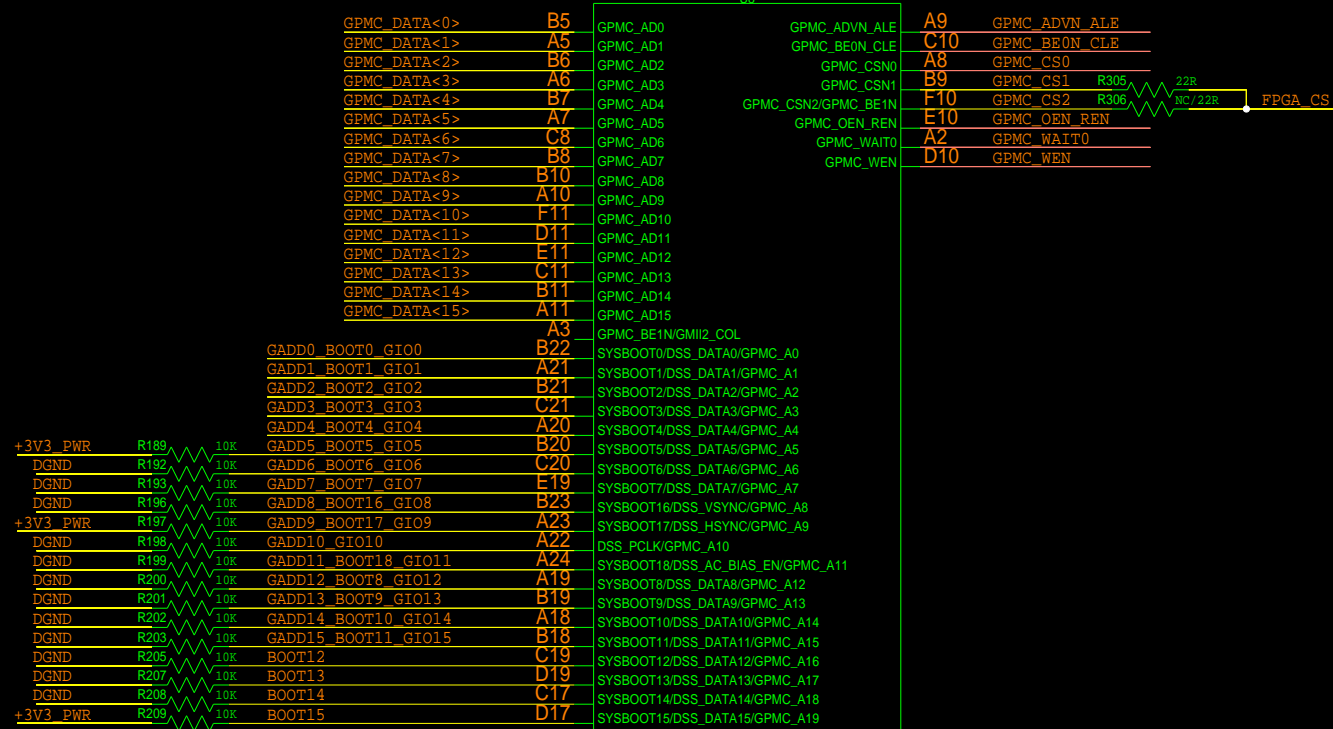

[15:14]--CLK=25MHZ  
 [17]--CLKOUT1 ENABLE

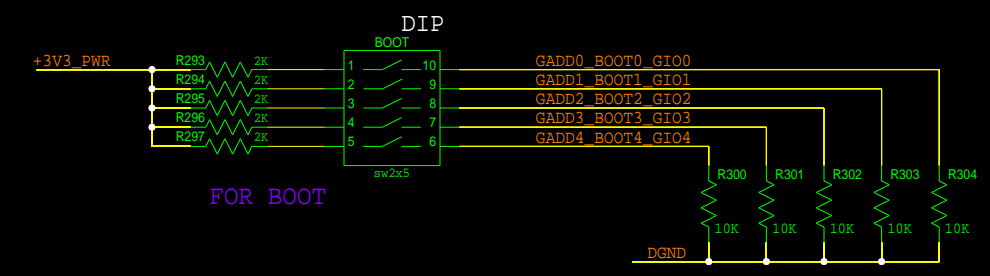

FOR BOOT

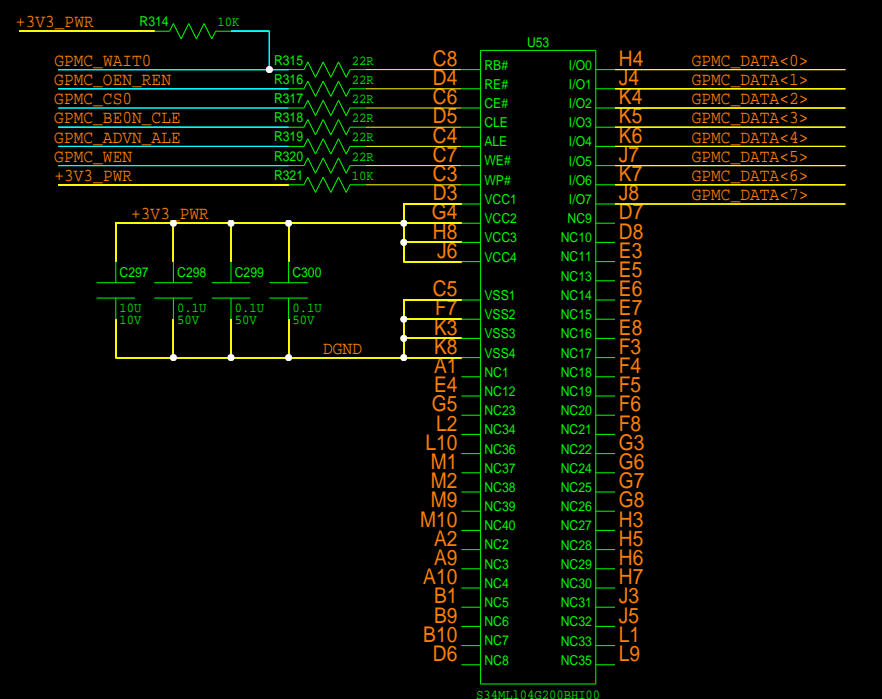
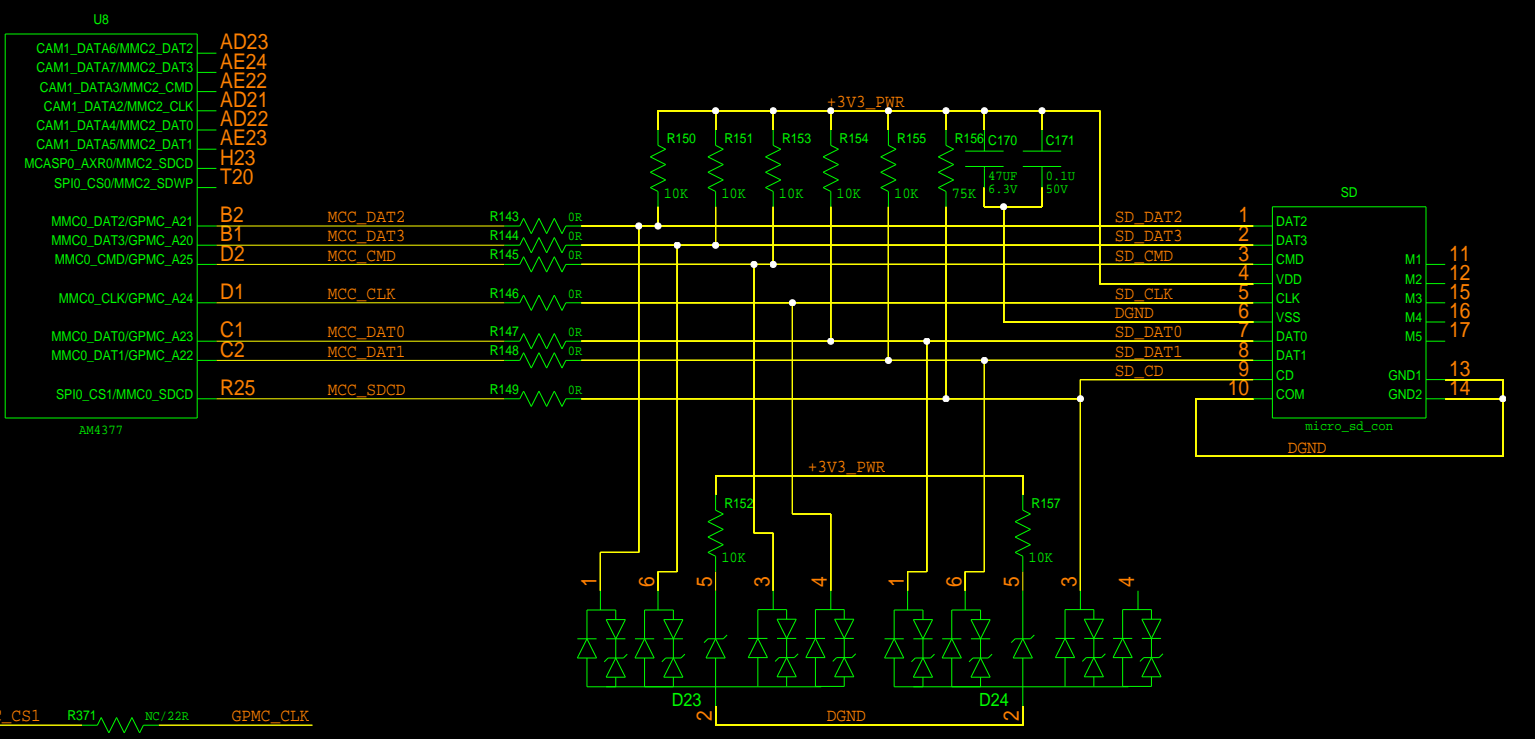
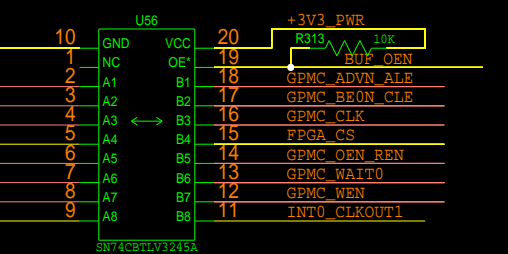
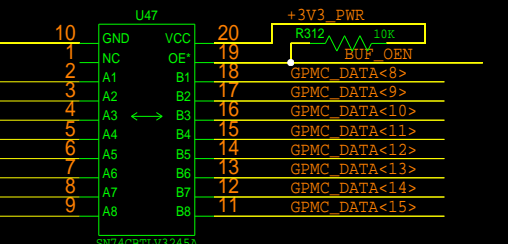
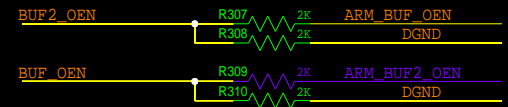
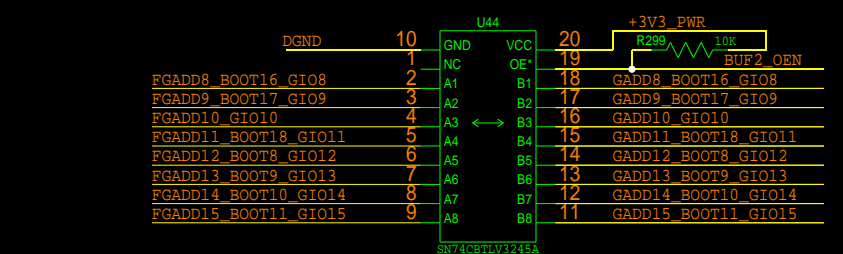
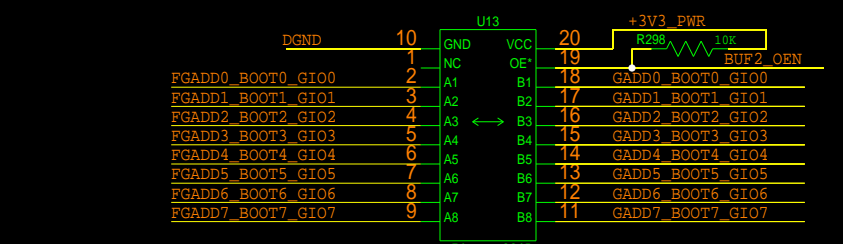

TITLE:	DATE:
ENGINEER:	PAGE:

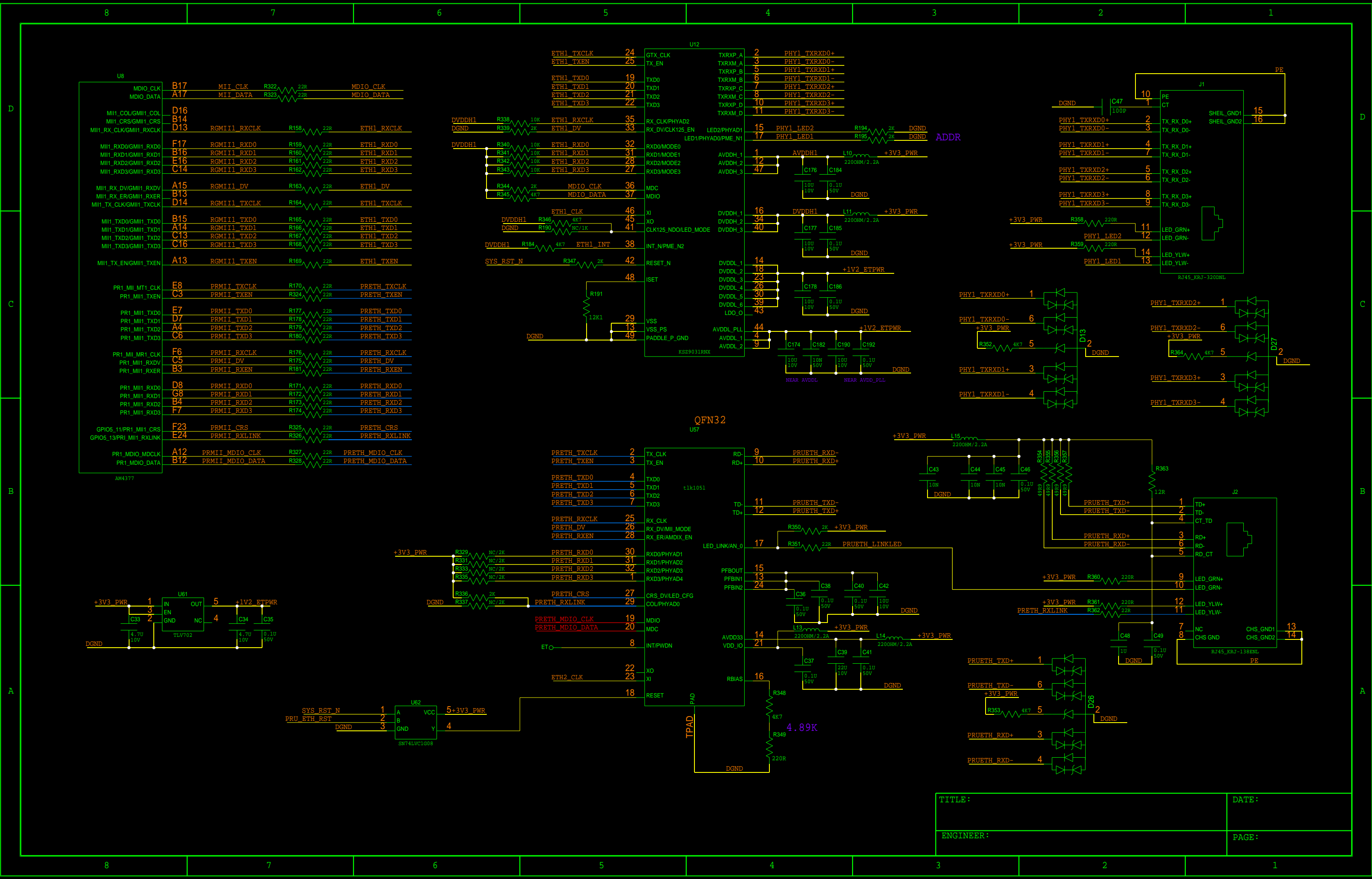

TITLE: \_\_\_\_\_ DATE: \_\_\_\_\_

ENGINEER: \_\_\_\_\_ PAGE: \_\_\_\_\_



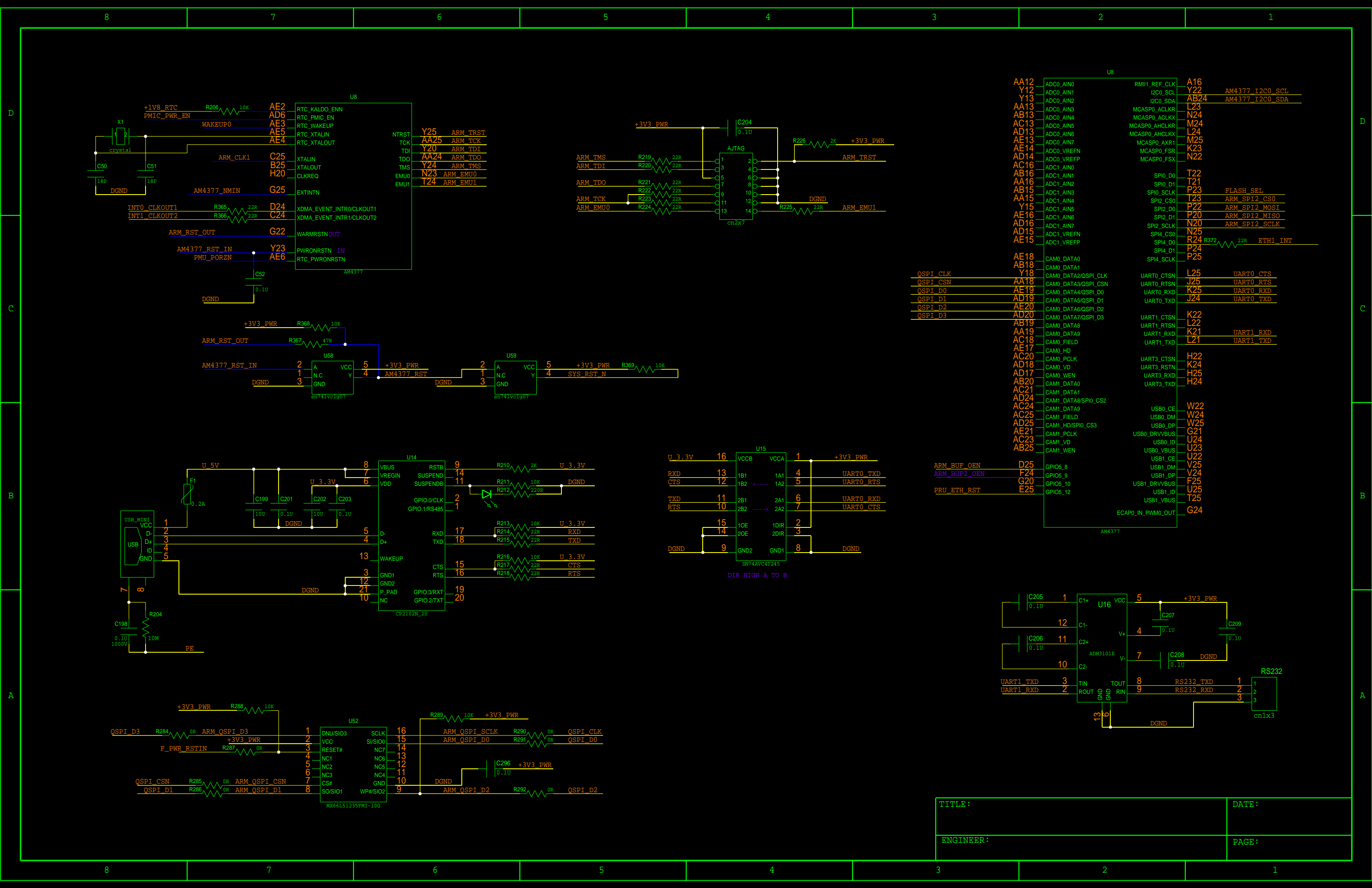

AA12	ADC0_AIN0	RMI1_REF_CLK	A16	
Y12	ADC0_AIN1	I2C0_SCL	Y22	AM4377 I2C0_SCL
Y13	ADC0_AIN2	I2C0_SDA	AB24	AM4377 I2C0_SDA
AA13	ADC0_AIN3	MCASP0_ACLKR	L23	
AB13	ADC0_AIN4	MCASP0_ACLKX	N24	
AC13	ADC0_AIN5	MCASP0_AHCLKR	M24	
AD13	ADC0_AIN6	MCASP0_AHCLKX	L24	
AE13	ADC0_AIN7	MCASP0_AXR1	M25	
AE14	ADC0_VREFN	MCASP0_FSR	K23	
AD14	ADC0_VREFP	MCASP0_FSX	N22	
AC16	ADC1_AIN0			
AB16	ADC1_AIN1	SPI0_D0	T22	
AA16	ADC1_AIN2	SPI0_D1	T21	
AB15	ADC1_AIN3	SPI0_SCLK	P23	FLASH_SEL
AA15	ADC1_AIN4	SPI2_CS0	T23	ARM_SPI2_CS0
Y15	ADC1_AIN5	SPI2_D0	P22	ARM_SPI2_MOSI
AE16	ADC1_AIN6	SPI2_D1	P20	ARM_SPI2_MISO
AD16	ADC1_AIN7	SPI2_SCLK	N20	ARM_SPI2_SCLK
AD15	ADC1_VREFN	SPH_CS0	N25	
AE15	ADC1_VREFP	SPH_D0	R24	ETH1_INT
		SPH_D1	P24	
AE18	CAM0_DATA0	SPH_SCLK	P25	
AB18	CAM0_DATA1			
Y18	CAM0_DATA2/QSPI_CLK	UART0_CTSN	L25	UART0_CTS
AA18	CAM0_DATA3/QSPI_CSN	UART0_RTSN	J25	UART0_RTS
AD19	CAM0_DATA4/QSPI_D0	UART0_RXD	K25	UART0_RXD
AE20	CAM0_DATA5/QSPI_D1	UART0_TXD	J24	UART0_TXD
AD20	CAM0_DATA6/QSPI_D2			
AB19	CAM0_DATA7/QSPI_D3	UART1_CTSN	K22	
AC18	CAM0_DATA8	UART1_RTSN	L22	
AE17	CAM0_DATA9	UART1_RXD	K21	UART1_RXD
AC20	CAM0_FIELD	UART1_TXD	L21	UART1_TXD
AD18	CAM0_HD			
AD17	CAM0_PCLK	UART3_CTSN	H22	
AB20	CAM0_VD	UART3_RSTN	K24	
AC21	CAM1_DATA0	UART3_RXD	H25	
AD24	CAM1_DATA1	UART3_TXD	H24	
AC24	CAM1_DATA8/SPI0_CS2			
AD25	CAM1_DATA9	USB0_CE	W22	
AE21	CAM1_FIELD	USB0_DM	W24	
AC23	CAM1_HD/SPI0_CS3	USB0_DP	W25	
AB25	CAM1_PCLK	USB0_DRVVBUS	G21	
	CAM1_VD	USB0_ID	U24	
	CAM1_WEN	USB0_VBUS	U23	
		USB1_CE	U22	
		USB1_DM	U25	
		USB1_DP	V24	
		USB1_DRVVBUS	F25	
		USB1_ID	U25	
		USB1_VBUS	T25	
		ECAP0_IN_PWM0_OUT	G24	

QSPI_CLK	Y18	UART0_CTSN	L25	UART0_CTS
QSPI_CSN	AA18	UART0_RTSN	J25	UART0_RTS
QSPI_D0	AE19	UART0_RXD	K25	UART0_RXD
QSPI_D1	AD19	UART0_TXD	J24	UART0_TXD
QSPI_D2	AE20			
QSPI_D3	AD20			
		UART1_CTSN	K22	
		UART1_RTSN	L22	
		UART1_RXD	K21	UART1_RXD
		UART1_TXD	L21	UART1_TXD
		UART3_CTSN	H22	
		UART3_RSTN	K24	
		UART3_RXD	H25	
		UART3_TXD	H24	
		USB0_CE	W22	
		USB0_DM	W24	
		USB0_DP	W25	
		USB0_DRVVBUS	G21	
ARM_BUF_OEN	D25	USB0_ID	U24	
ARM_BUF2_OEN	F24	USB0_VBUS	U23	
		USB1_CE	U22	
		USB1_DM	U25	
		USB1_DP	V24	
		USB1_DRVVBUS	F25	
PRU_ETH_RST	G20	USB1_ID	U25	
	E25	USB1_VBUS	T25	
		ECAP0_IN_PWM0_OUT	G24	

TITLE:	DATE:
ENGINEER:	PAGE:

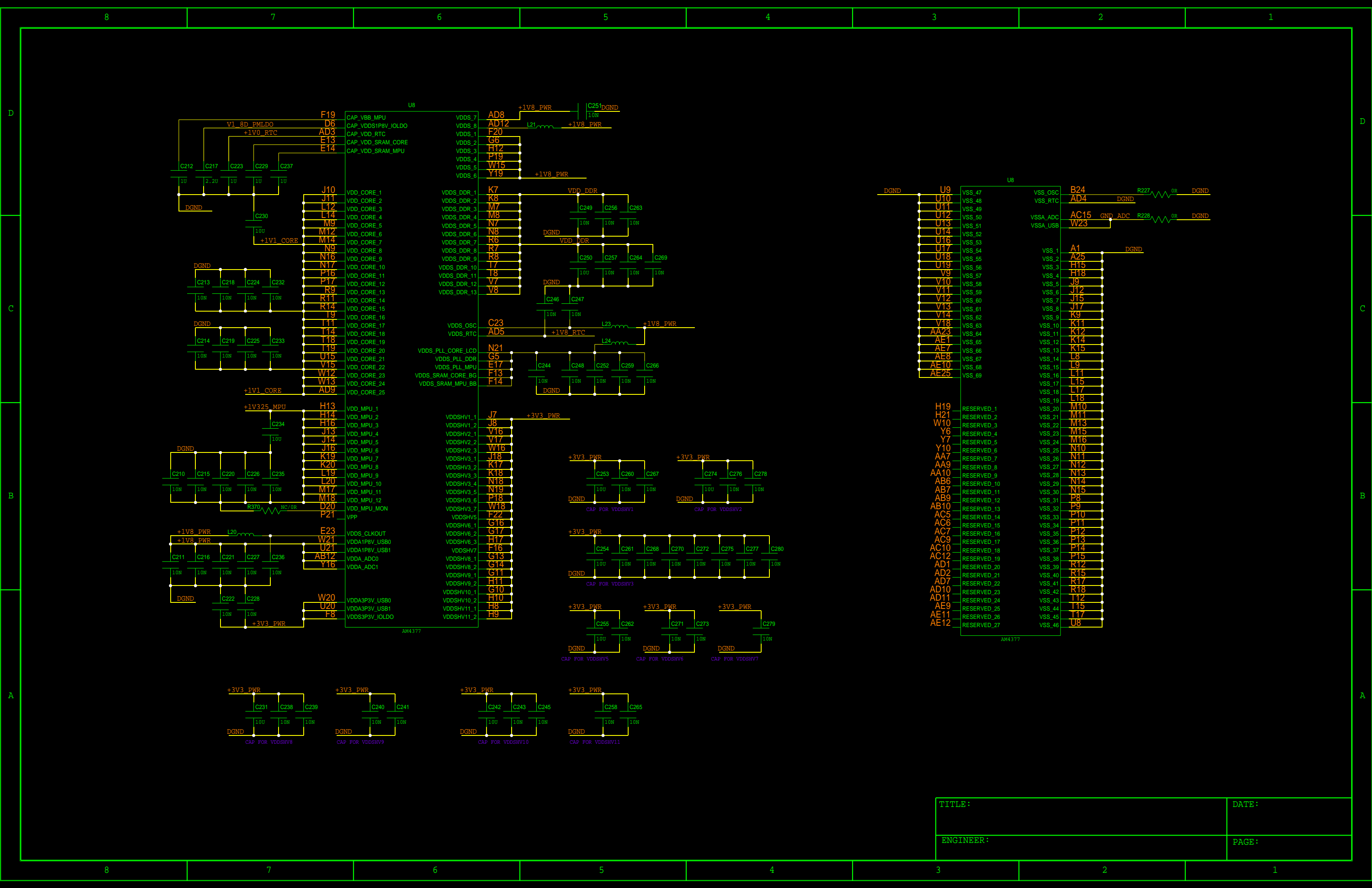

TITLE :	DATE :
ENGINEER :	PAGE :

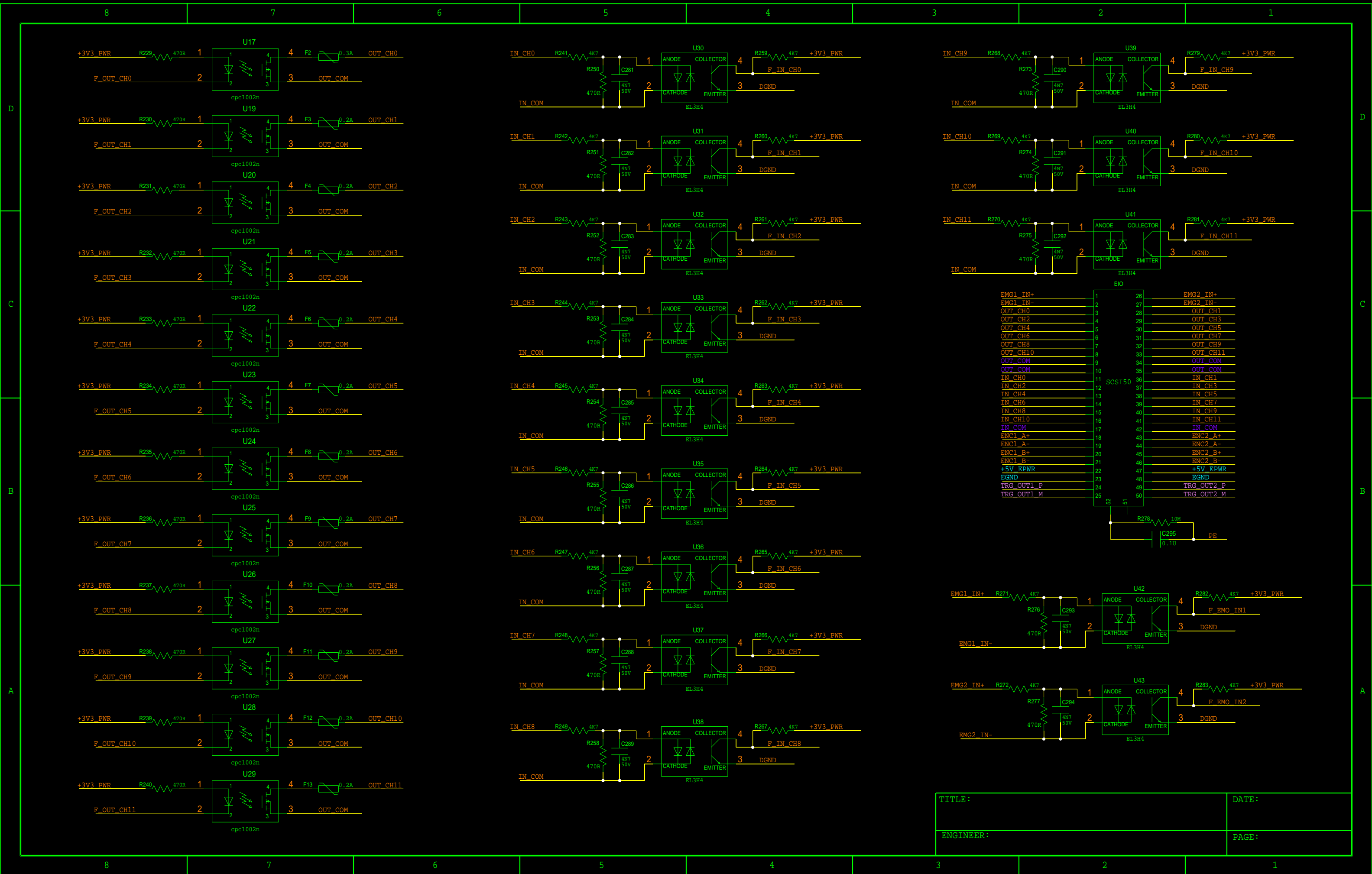

EIO	
EMG1 IN+	26
EMG1 IN-	27
OUT_CH0	28
OUT_CH1	29
OUT_CH2	30
OUT_CH3	31
OUT_CH4	32
OUT_CH5	33
OUT_CH6	34
OUT_CH7	35
OUT_CH8	36
OUT_CH9	37
OUT_CH10	38
OUT_CH11	39
OUT_COM	40
OUT_COM	41
OUT_COM	42
IN_CH0	43
IN_CH1	44
IN_CH2	45
IN_CH3	46
IN_CH4	47
IN_CH5	48
IN_CH6	49
IN_CH7	50
IN_CH8	
IN_CH9	
IN_CH10	
IN_CH11	
IN_COM	
IN_COM	
ENC1 A+	
ENC1 A-	
ENC1 B+	
ENC1 B-	
+5V_EPWR	
EGND	
TRG_OUT1_P	
TRG_OUT1_M	

TITLE:	DATE:
ENGINEER:	PAGE: