

Title		
<Title>		
Size	Document Number	Rev
B	<Doc>	<Rev Code>
Date:	Wednesday, September 29, 2021	Sheet 9 of 17

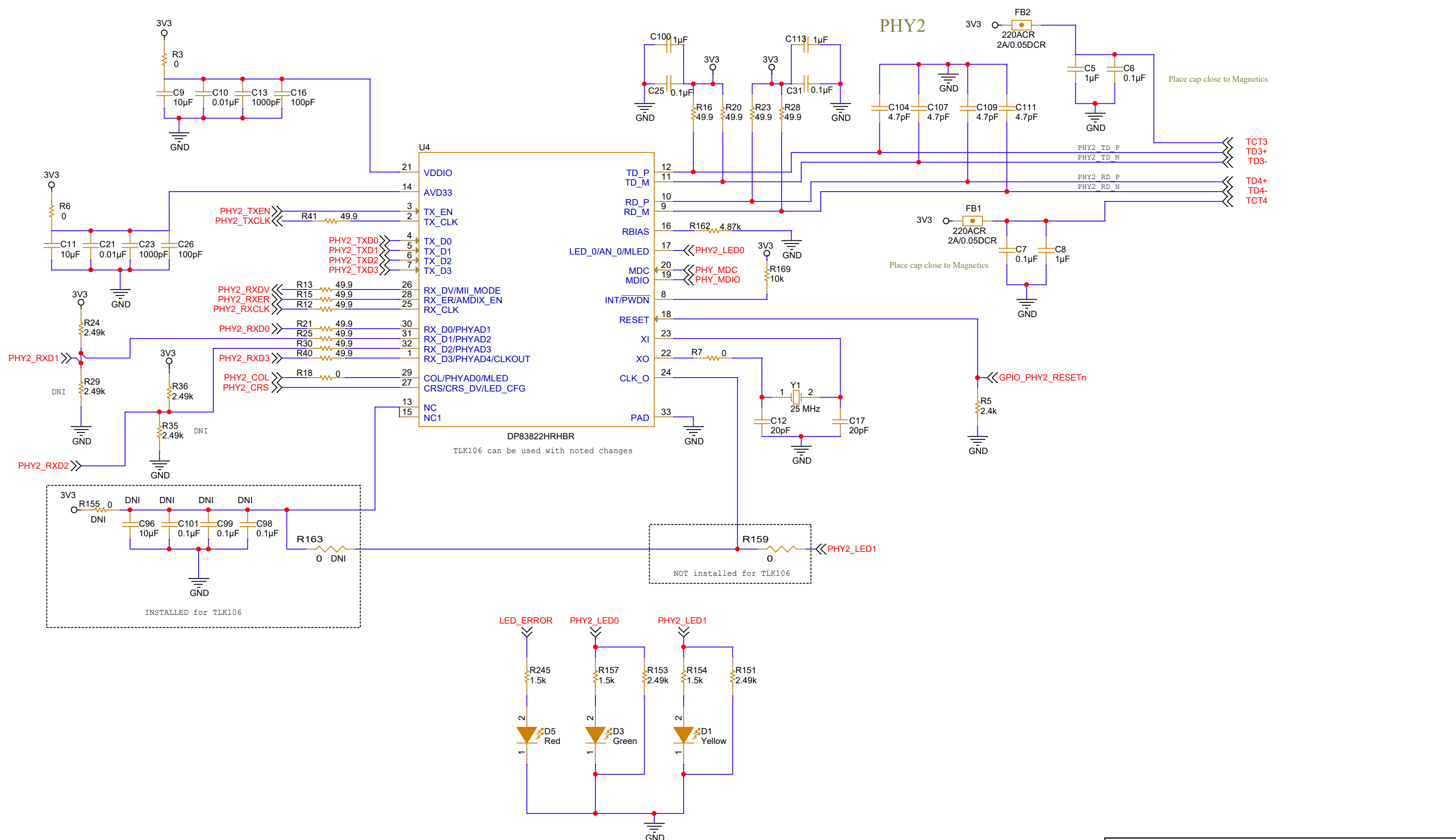

Title		
<Title>		
Size	Document Number	Rev
B	<Doc>	<Rev Code>
Date:	Wednesday, September 29, 2021	Sheet 10 of 17