

NOTE - 001

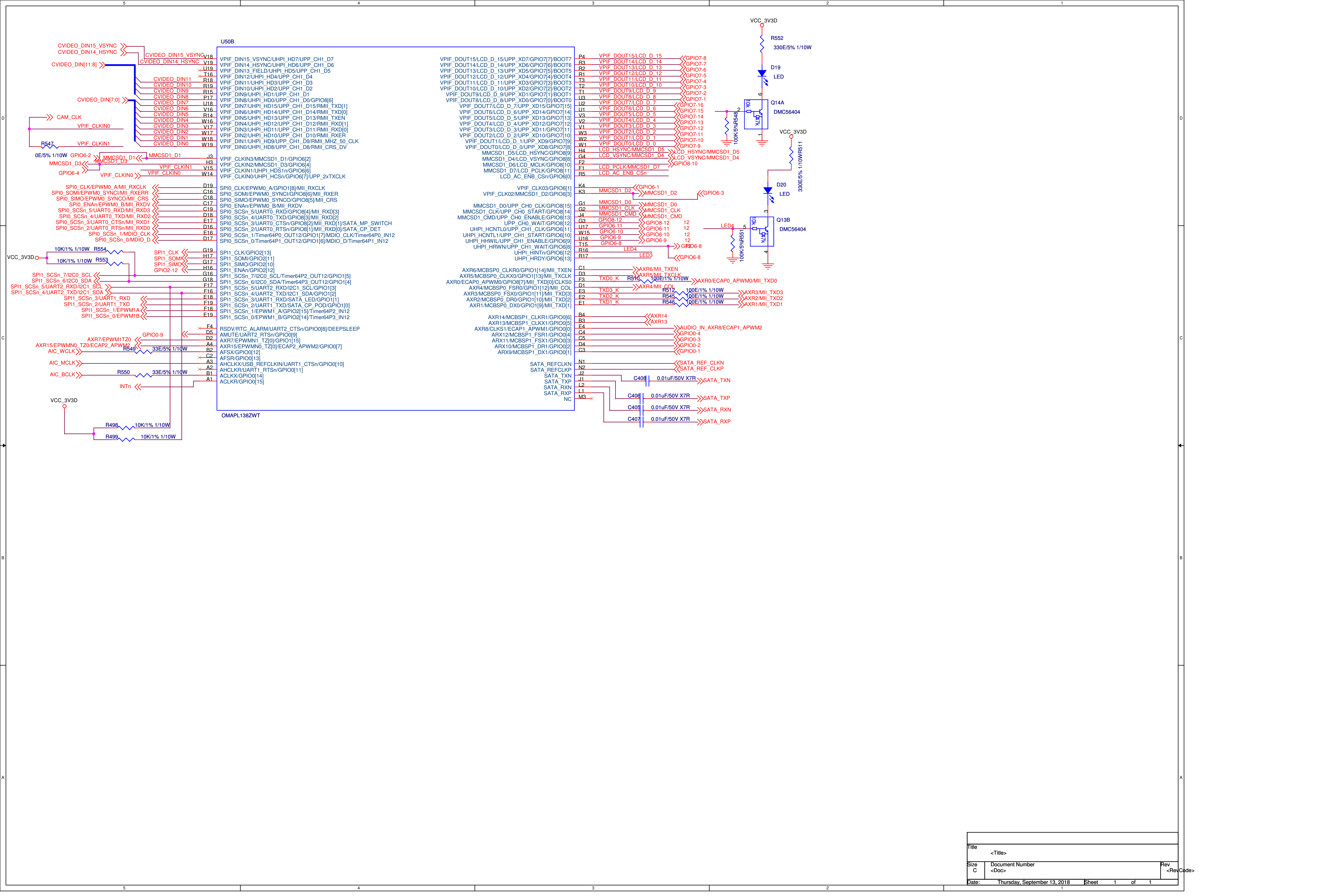

|       |                              |              |
|-------|------------------------------|--------------|
| Title |                              | <Title>      |
| Size  | Document Number              | Rev          |
| C     | <Doc>                        | <Rev Code>   |
| Date: | Thursday, September 13, 2018 | Sheet 1 of 1 |

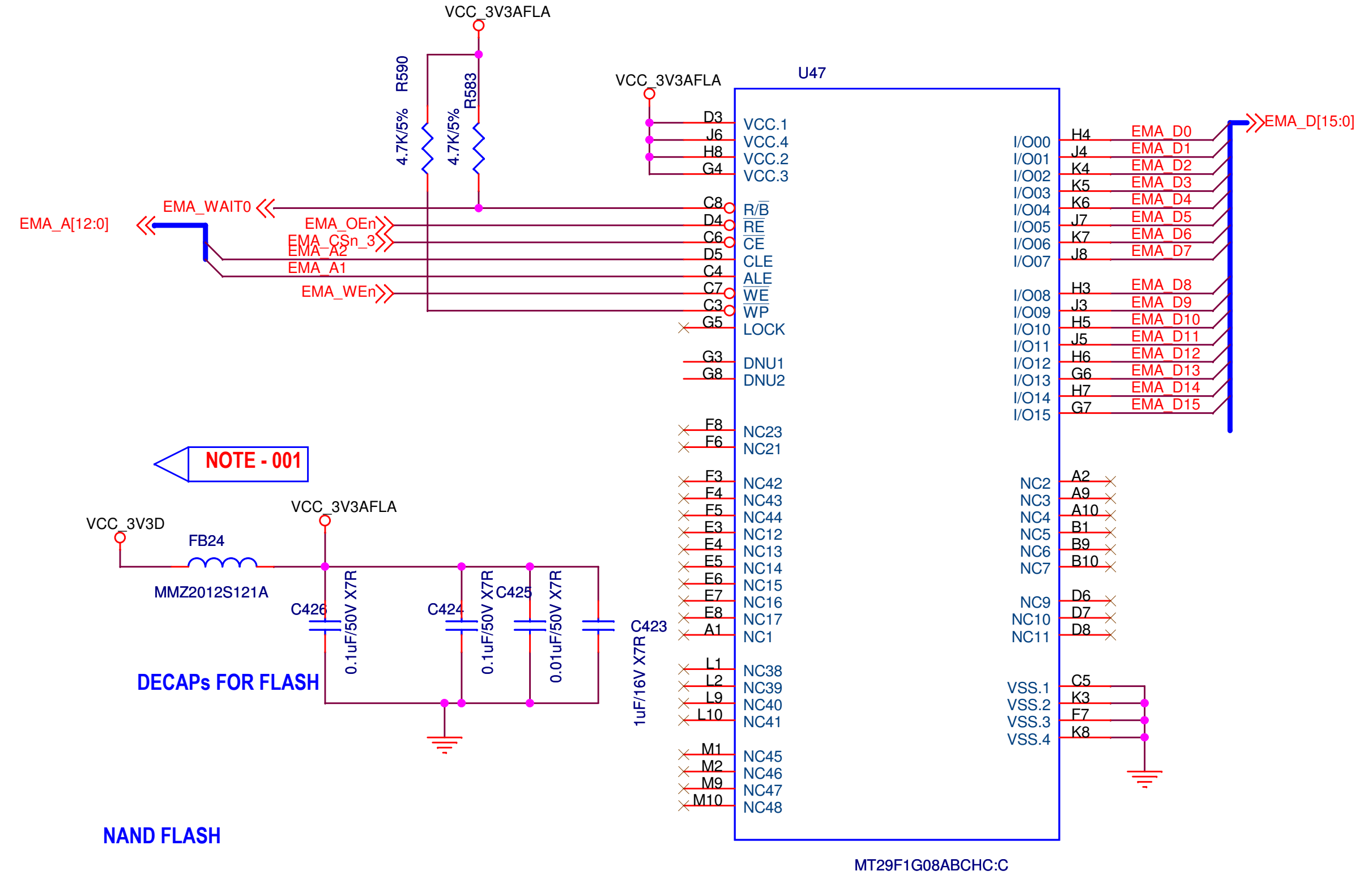
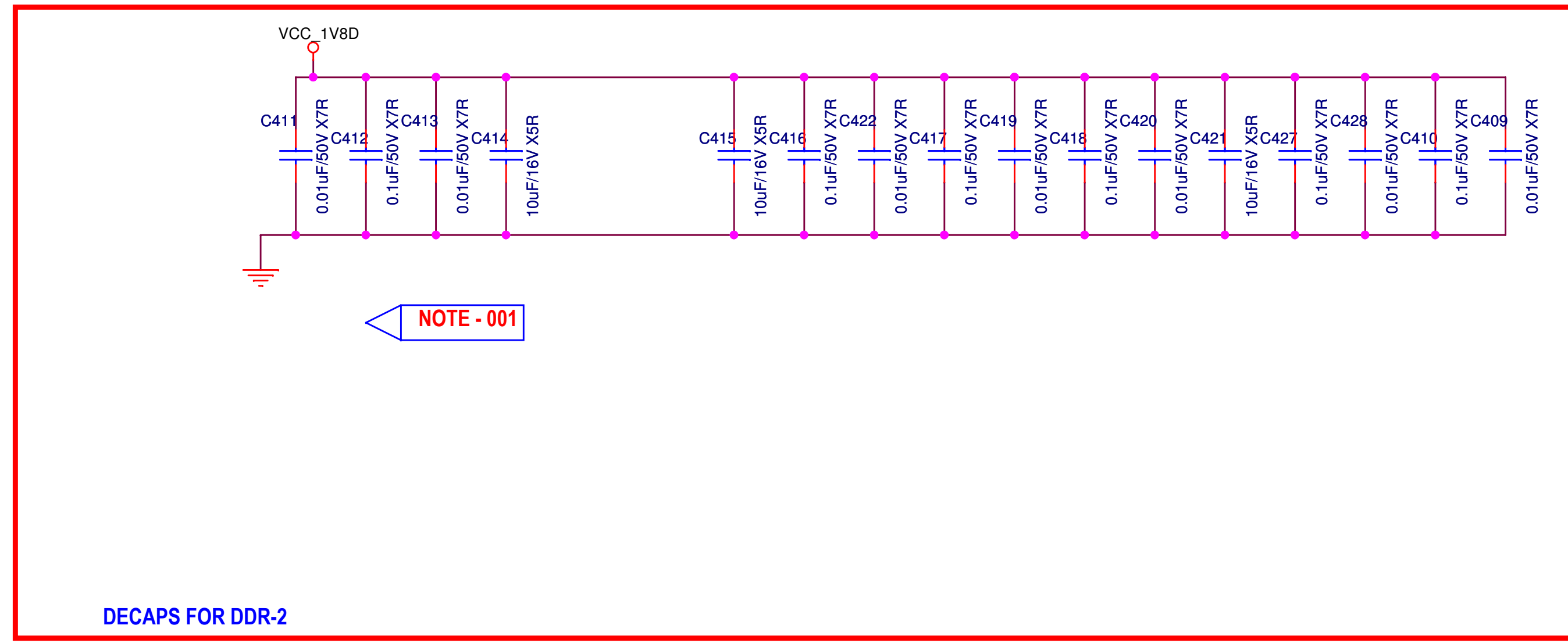
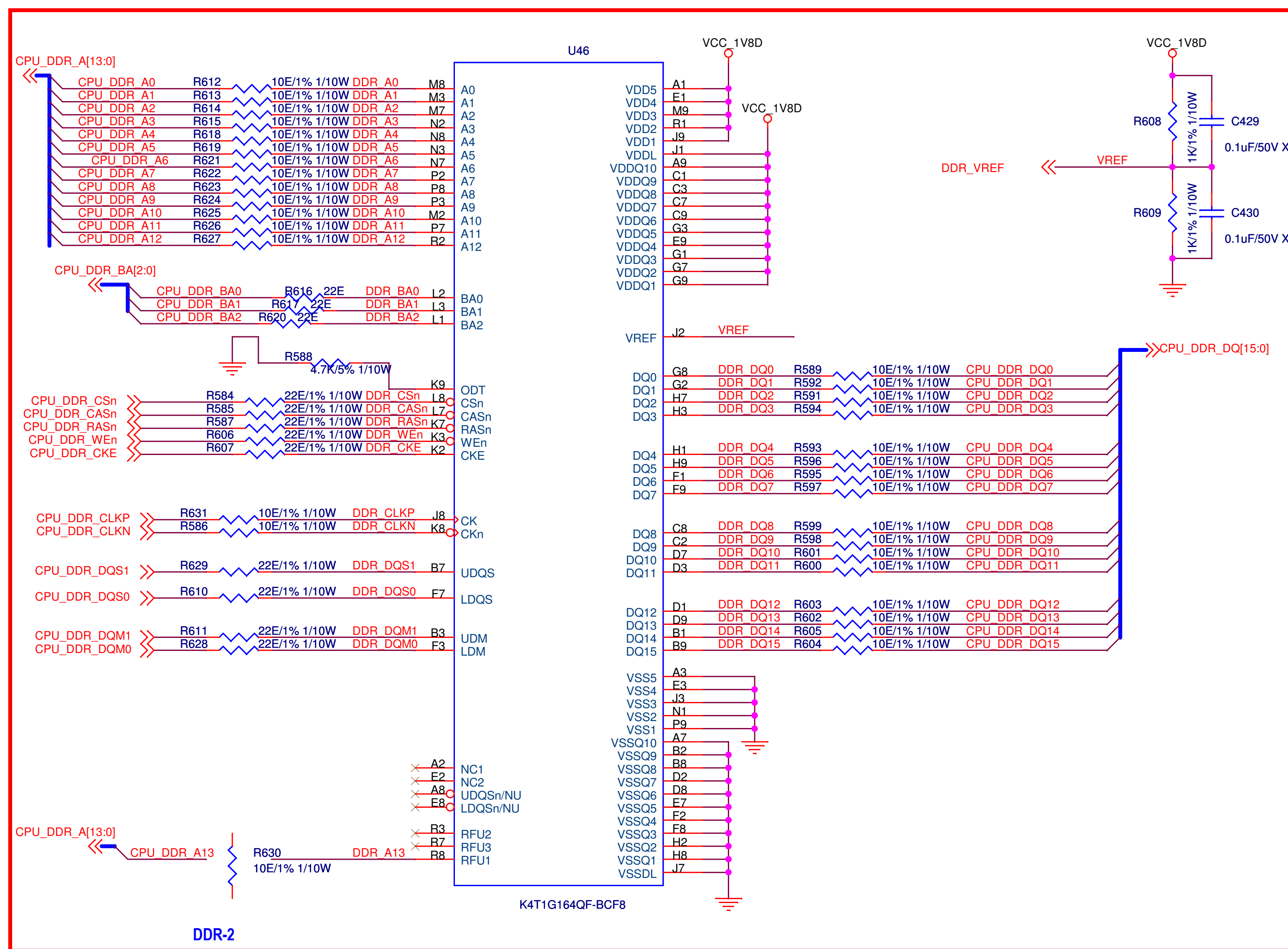

NOTE - 001 ALL DECAPS SHOULD BE PLACE WITHIN 1cm FROM EACH PIN

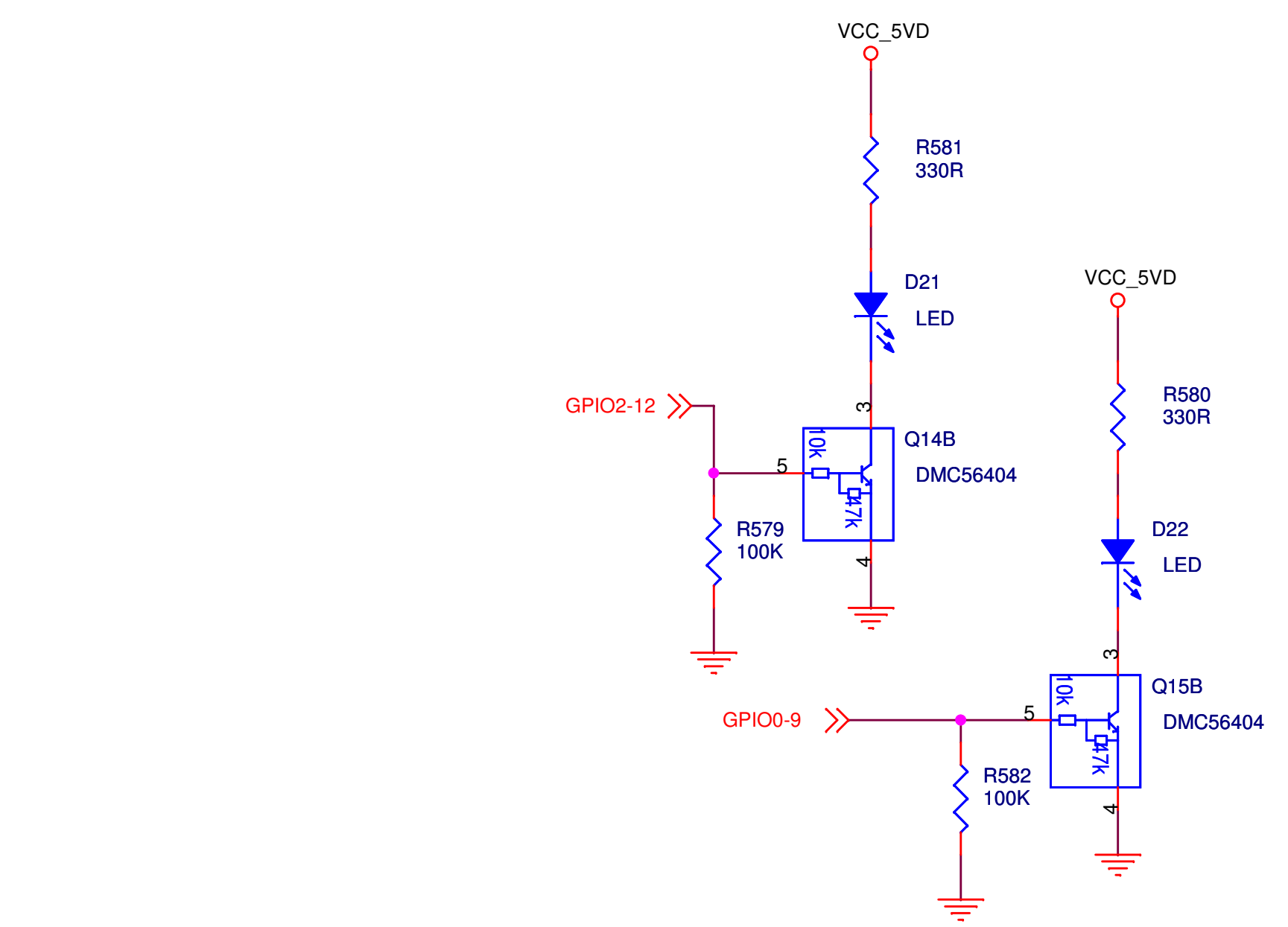

|  |                          |           |
|--|--------------------------|-----------|
| Texas Instruments, Inc.                    |                          |           |
| Title<br><b>OMAP-L138/C6748 LC Dev Kit</b> |                          |           |
| Size<br>C                                  | Document Number<br><Doc> | Rev<br>A5 |
| Date:<br>Thursday, September 13, 2018      | Sheet<br>8               | of<br>12  |

|                                       |                          |                   |
|---------------------------------------|--------------------------|-------------------|
| Title<br><Title>                      |                          |                   |
| Size<br>C                             | Document Number<br><Doc> | Rev<br><Rev Code> |
| Date:<br>Thursday, September 13, 2018 | Sheet<br>1               | of<br>1           |