

PAGE LIST	
PAGE	PAGE NAME
001	Content
002	002_Block Diagram
003	003_Power Tree
004	004_I2C Usage Diagram
005	005_DCDC & PMIC
006	006_SoC Power
007	007_SoC DCAPs
008	008_SoC DDR & DDR4
009	009_SoC SDIO & eMMC & SD
010	010_SoC RGMII & GBE PHY
011	011_PHY Switch
012	012_SoC DDS & NAND FLASH
013	013_SoC GPIO 3.3V
014	014_SoC GPIO 1.8V & Bootstrap
015	015_SoC USB & USB_C & DC_IN
016	016_SoC Reset & MCU
017	017_SoC CSI & OLDI & JTAG
018	018_RTC & EEPROM & WDT
019	019_CONNECTOR_RJ45_0&1
020	020_FPGA_LVDS
021	021_FPGA_USB
022	022_BUTTON & MH
023	023_GPIOs
024	024_CONNECTOR

REVISION HISTORY			
VER #	DATE	DESCRIPTION OF CHANGES	AUTHOR
1.0			Dylan Chen
1.2			

南京德克威尔自动化 DECOWELL		
File: RX PLC Mesh board		
Size: A3	Document Number: 001_Content	Rev: V1.0
Date: Tuesday, January 16, 2024	Sheet: 1	of 24

Function Block Diagram

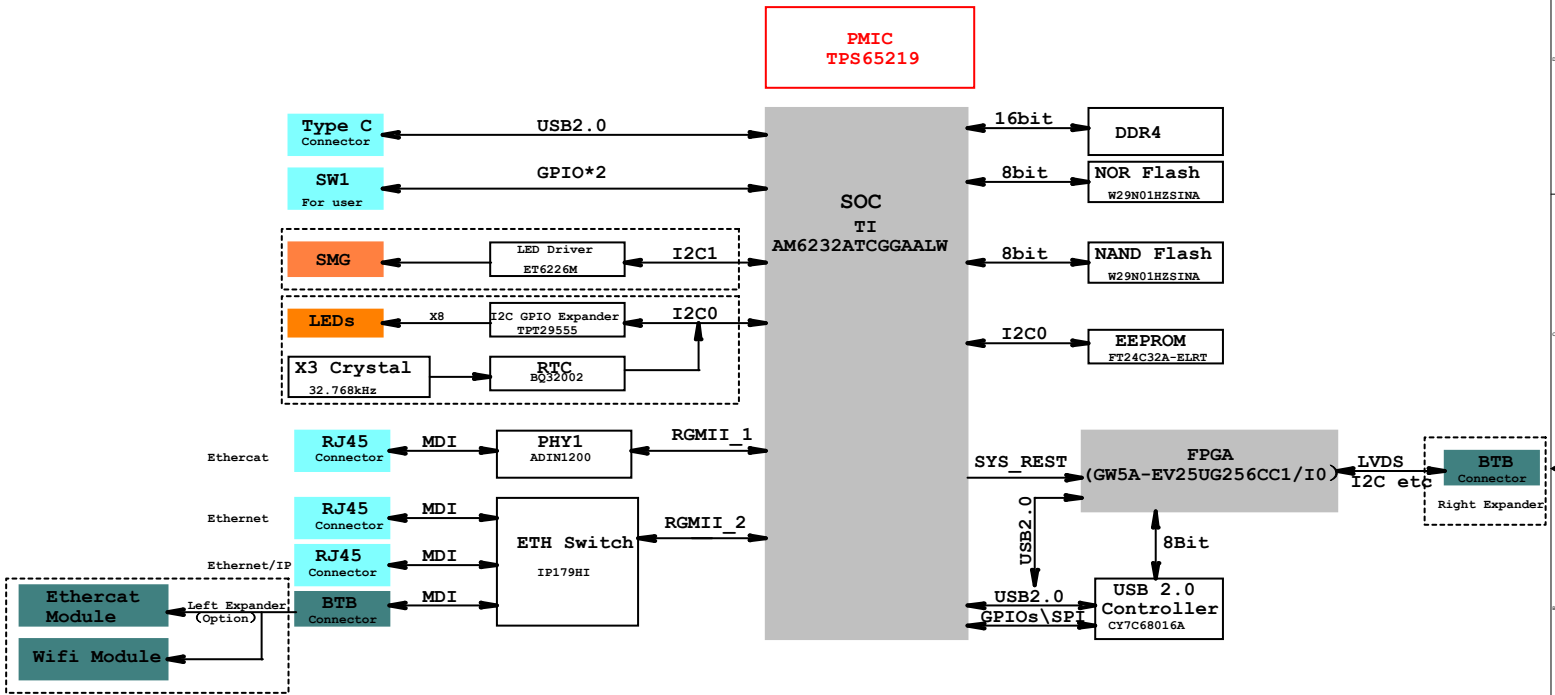

Power tree

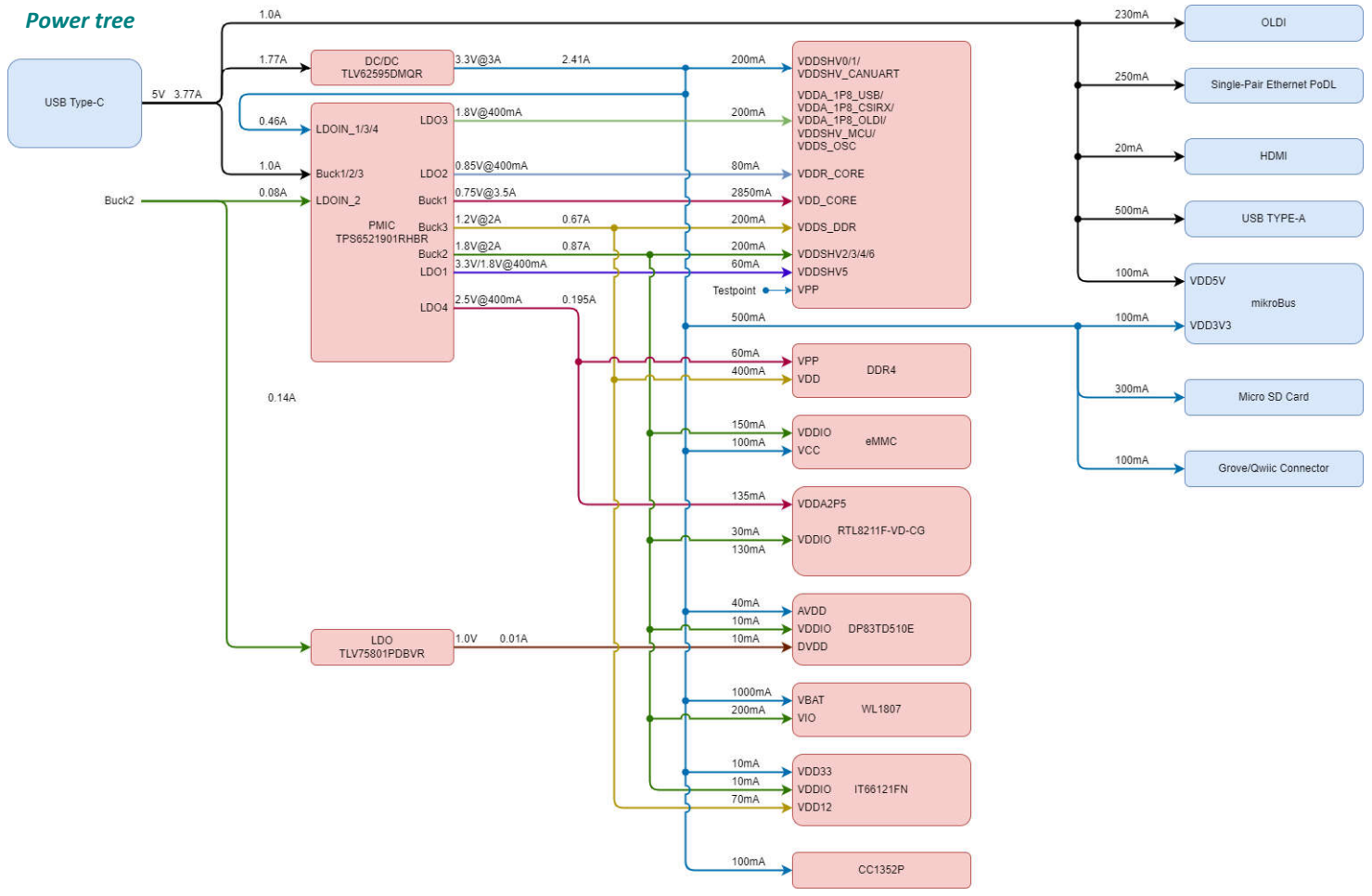

I2C Usage Diagram

	IC	Address
I2C0	PMIC (U3)	0x30 (0b0110000)
	EEPROM (U15)	0x50 (0b1010000)
	RTC (U16)	0xB8 (0b1101000)
	I/O Expander (On LED board)	0x20 (0b0100000)
I2C1	LED driver (On LED board)	

PWR LED

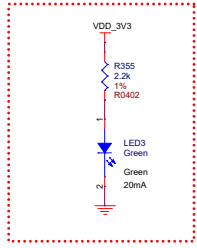

DCDC 3V3

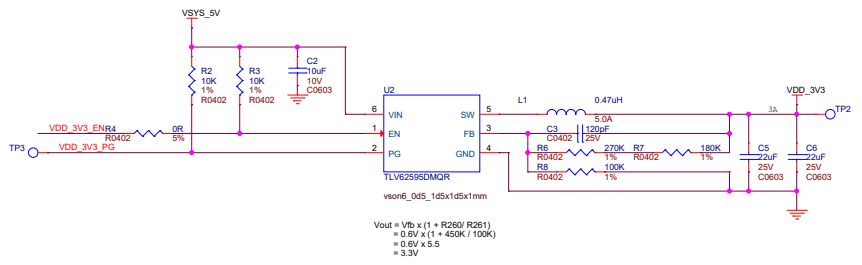

PMIC

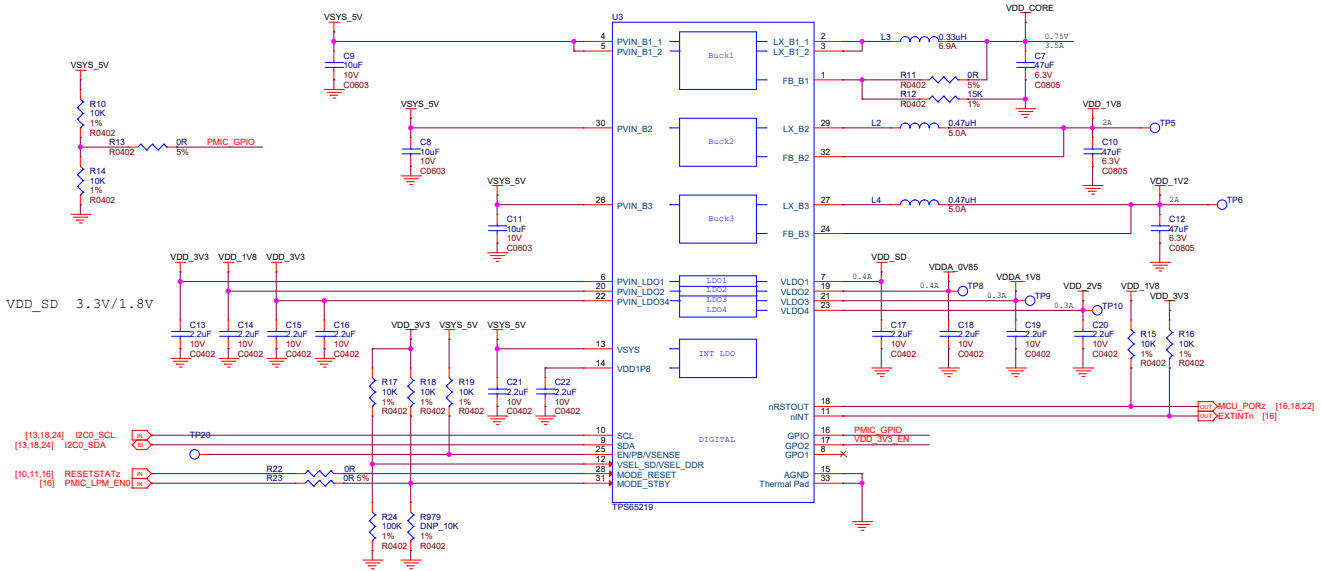

南京德克威尔自动化		DECOWELL	
File: RX PLC Main board			
Size: A3	Document Number: D05_D0DC & PMIC	Rev: V1.0	
Date: Tuesday, January 16, 2024	Sheet: 5	of 24	

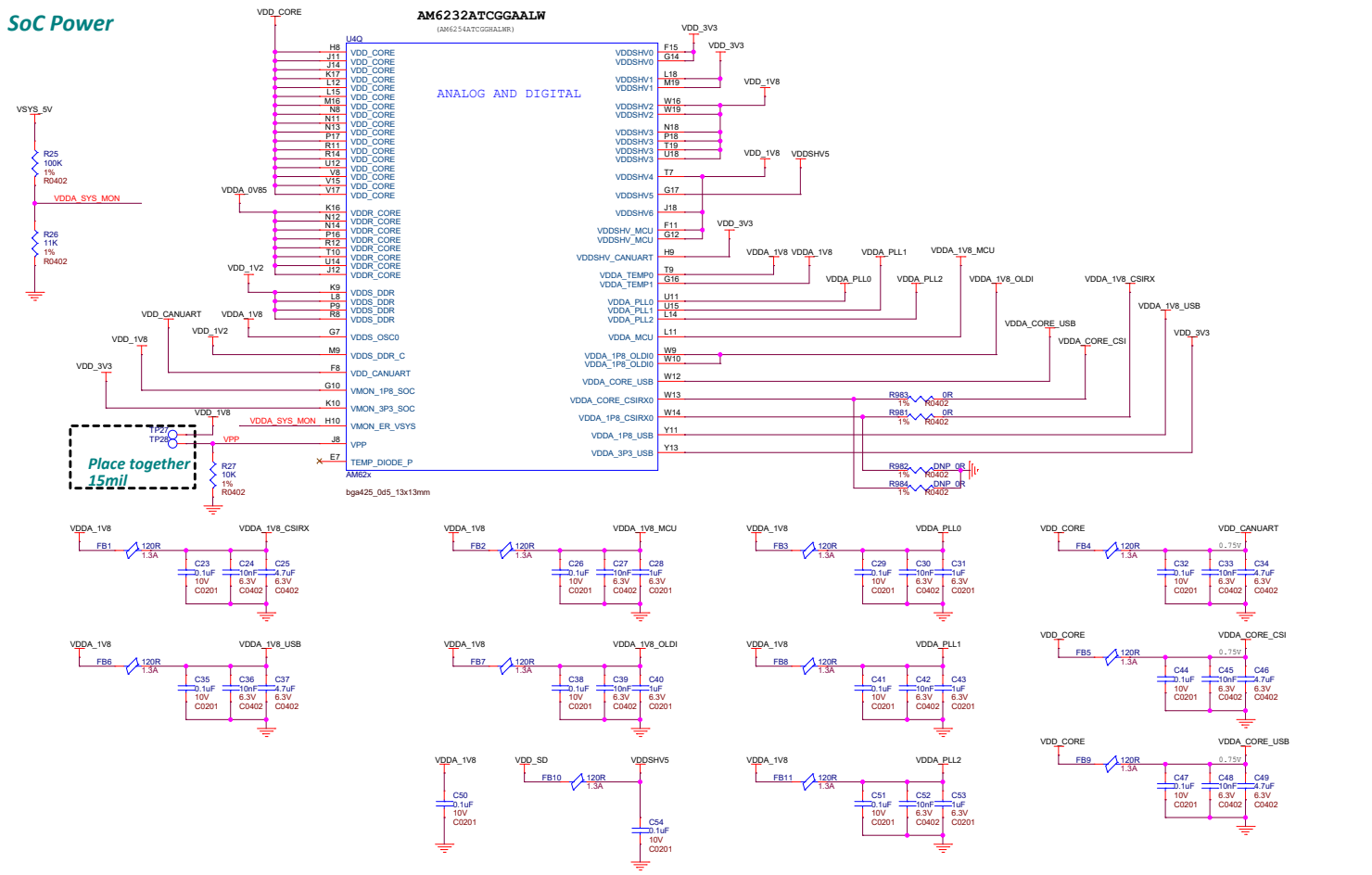

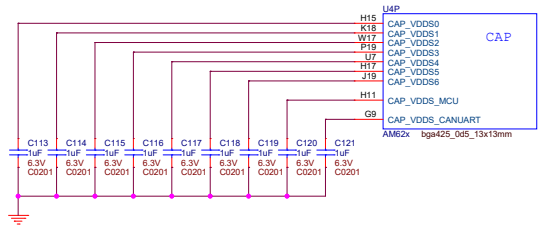
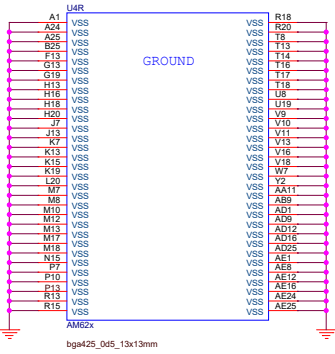
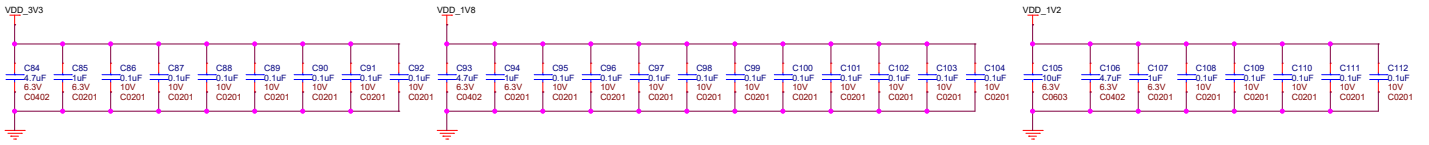
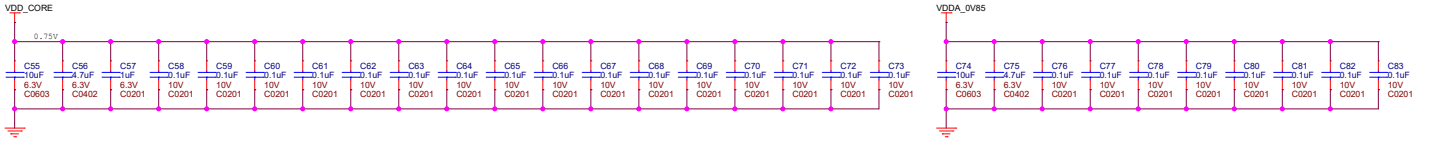

南京德克威尔自动化 **DECOWELL**

File: RX PLC Main board		
Size: A3	Document Number: 007-SoC DCAPs	Rev: V1.0
Date: Tuesday, January 16, 2024	Sheet: 7	of 24

eMMC/SD

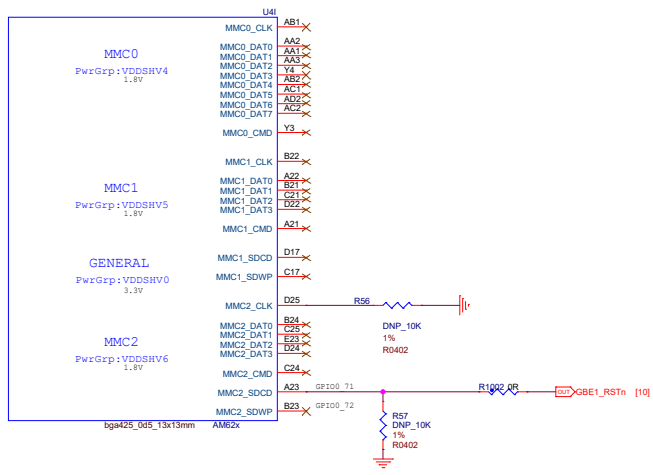

南京德克威尔自动化			DECOWELL
File: RX PLC Main board			
Size: A3	Document Number: D09_Soc-SDIO & eMMC & SD	Rev: V1.0	
Date: Tuesday, January 16, 2024	Sheet: 9	of: 24	

Gigabit Ethernet 1

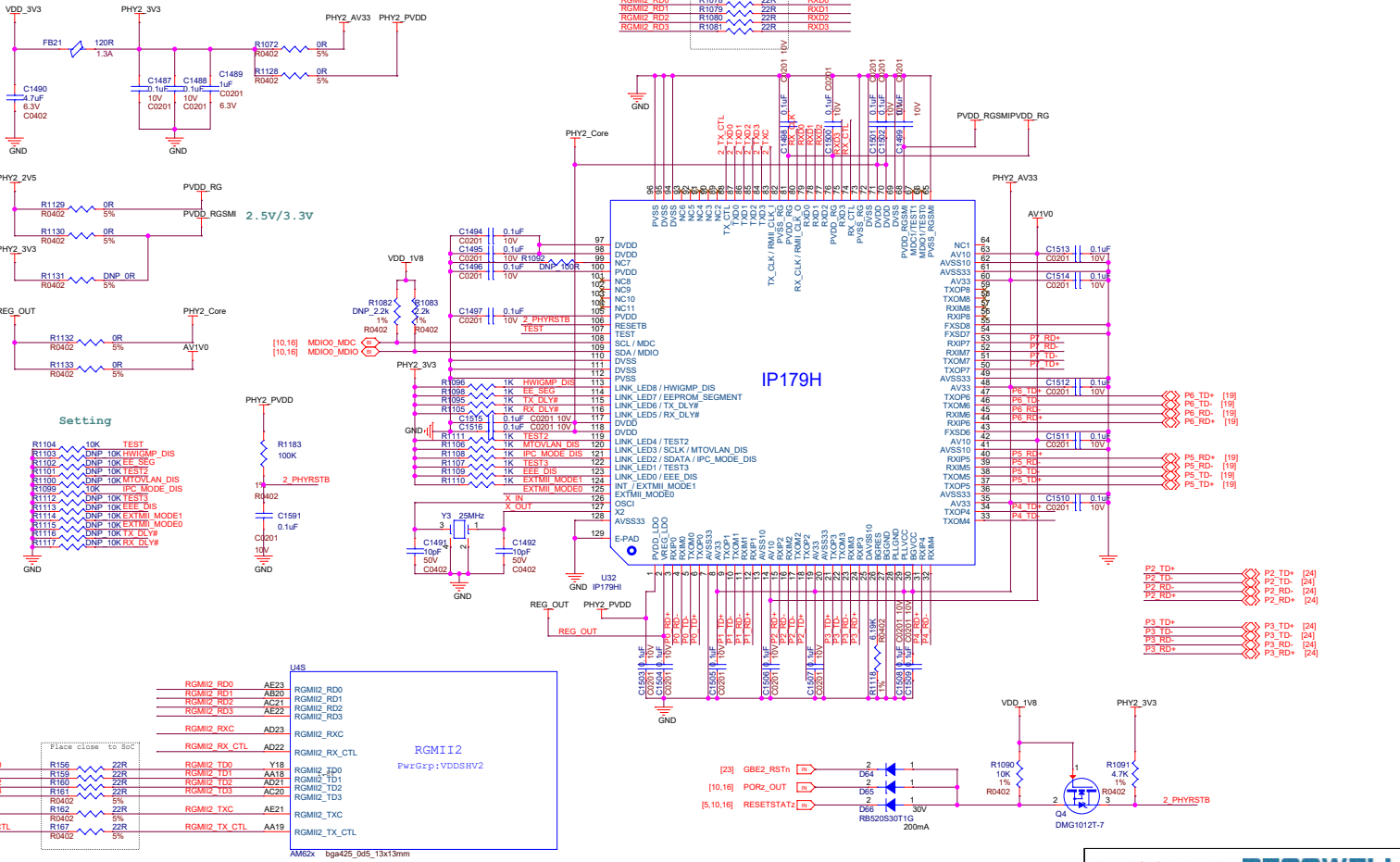

南京德克威尔自动化 **DECOWELL**

File: RX PLC Main board

Size: A3 Document Number: 011_Phy Switch Rev: V1.0

Date: Tuesday, January 16, 2024 Sheet: 11 of 24

国产兆易创新型号
GD9FS2G8F2AMG1



表 2-41 NAND Flash 接口布线要求

参数	要求
阻抗控制	50±10%单端
最大走线长度	TBD
信号等长	≤10mm
信号间最小距离	≥3H
时钟信号与其他信号间距	≥5H

USB_A & USB_C

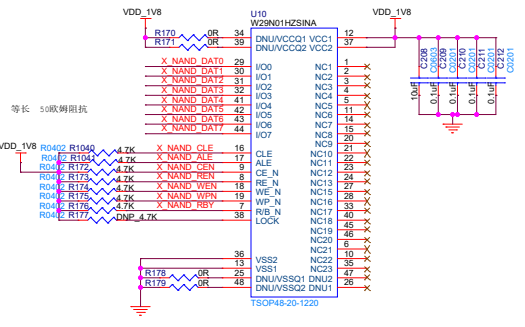
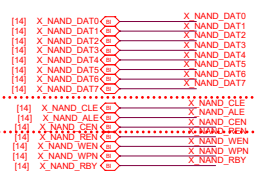
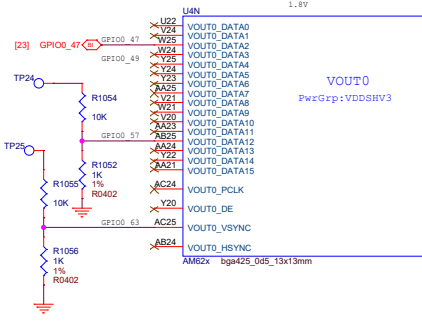
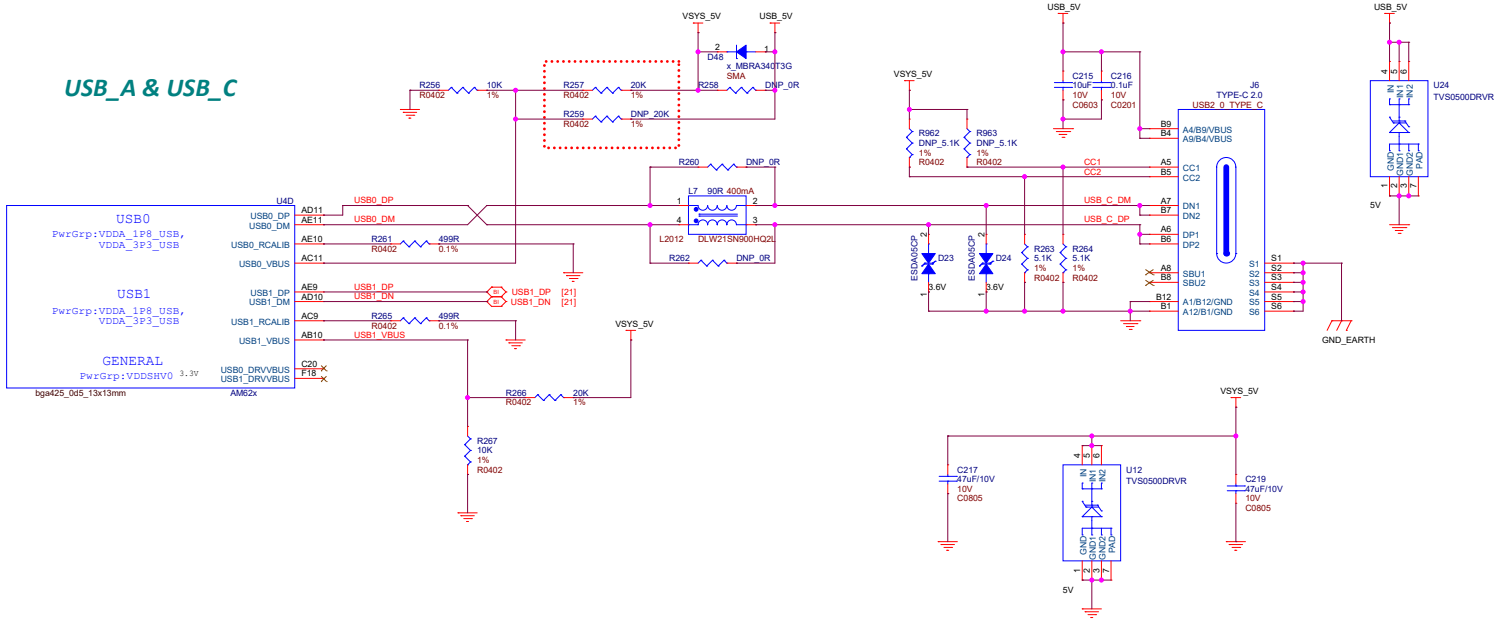

南京德克威尔自动化 **DECOWELL**

File: RX PLC Main board		
Size: A3	Document Number: D15_Soc USB & USB_C & DC_IN	Rev: V1.0
Date: Tuesday, January 16, 2024	Sheet: 15	of: 24

BOARD ID EEPROM 4Kbit

RTC

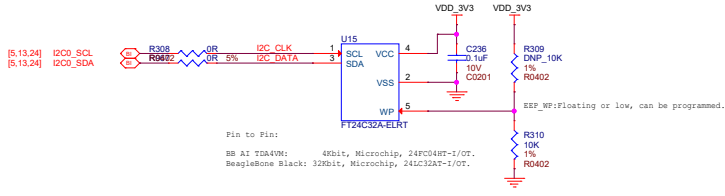

RTC电路放在电源板

WDT

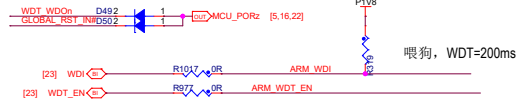
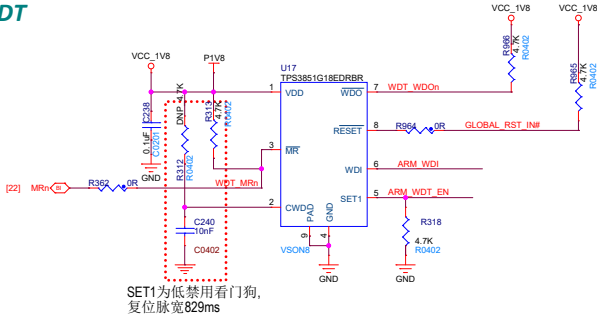

看门狗使能，高有效

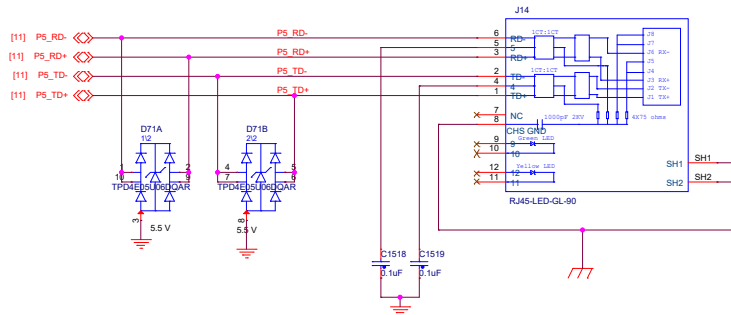
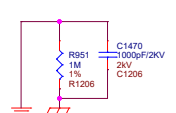
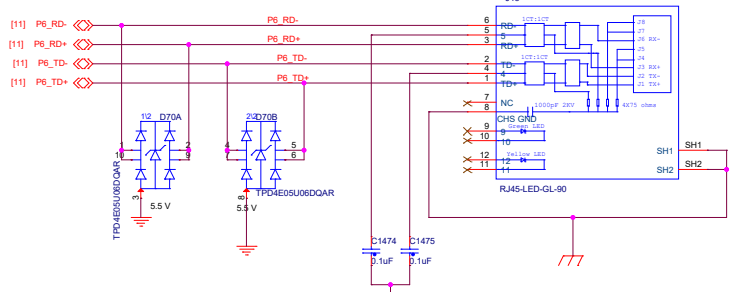
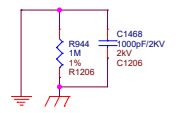
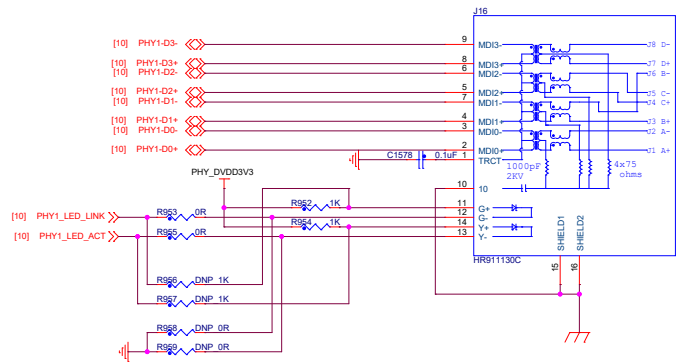

南京德克威尔自动化 **DECOWELL**

File: RX PLC Main board

Size: A3	Document Number: D19_CONNECTOR_RJ45_041	Rev: V1.0
Date: Tuesday, January 16, 2024	Sheet: 19	of: 24

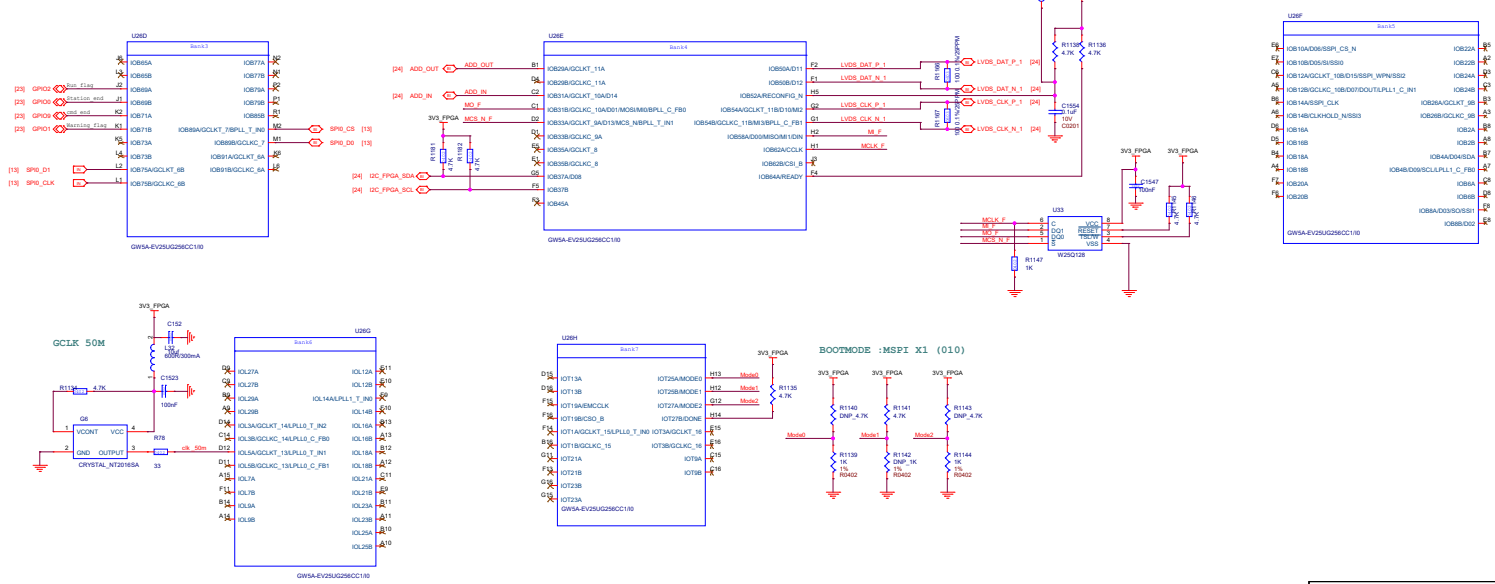
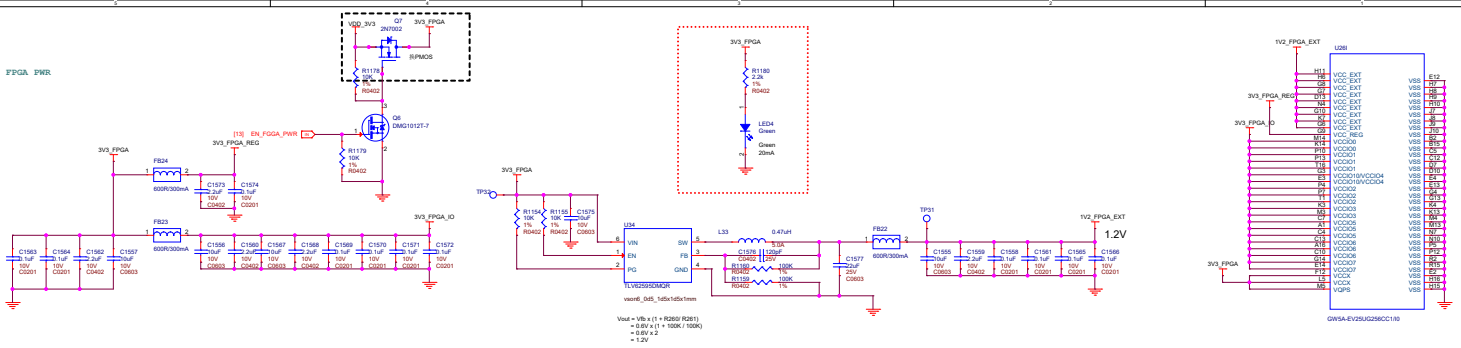

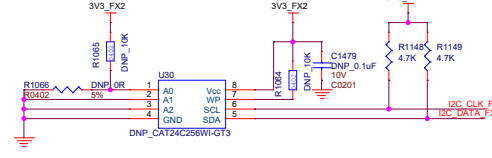
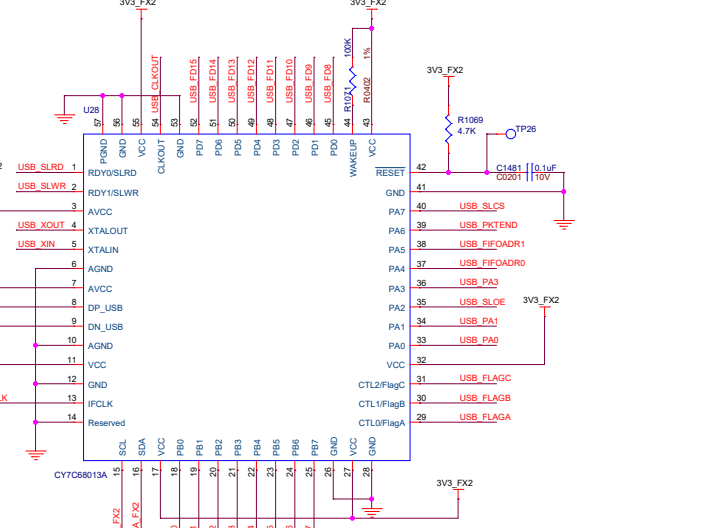
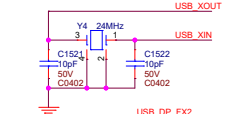
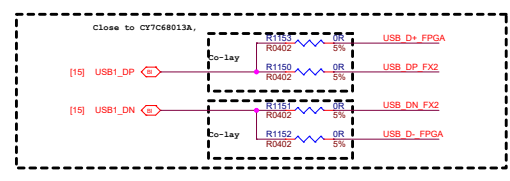
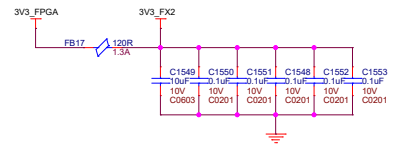
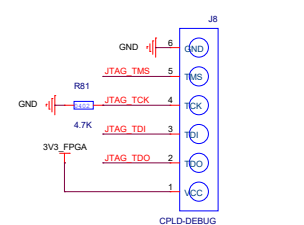
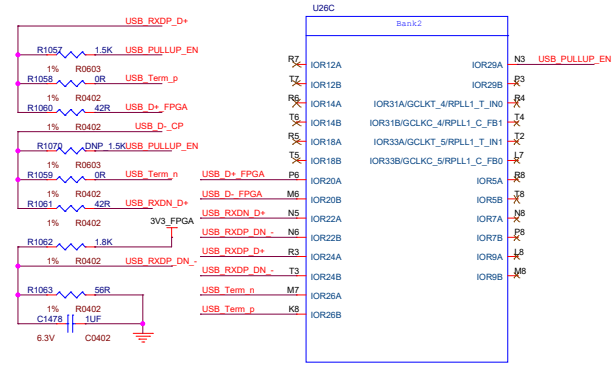
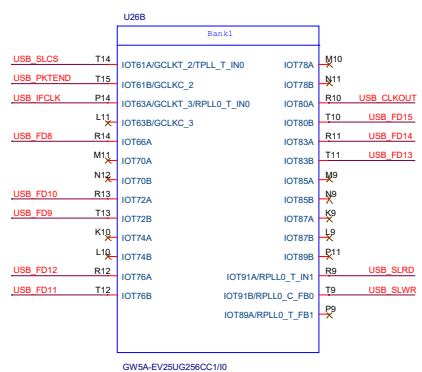
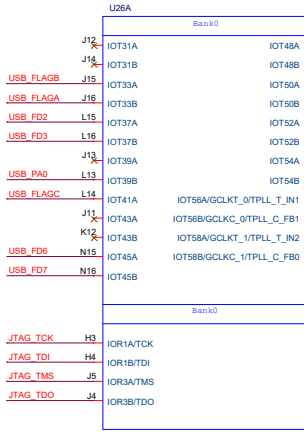

南京德克威尔自动化 DECCWELL

File			
RX PLC Main board			
Size	Document Number	Rev	
A3	021_FPGA_USB	V1.0	
Date:	Tuesday, January 16, 2024	Sheet	21 of 24

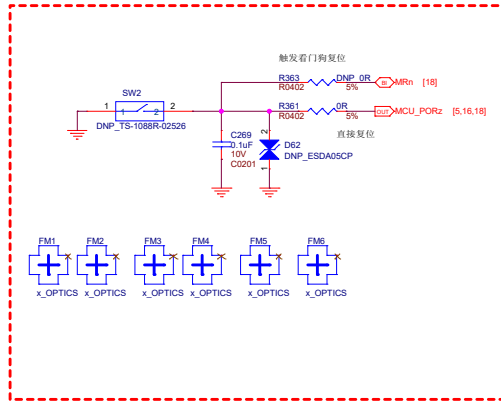
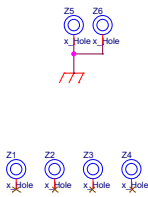
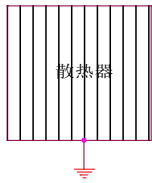
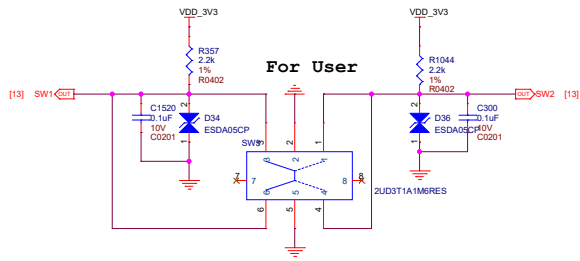

南京德克威尔自动化 DECOWELL		
File	RX PLC Main board	
Size	Document Number	Rev
A3	022_BUTTON & M4	V1.0
Date:	Tuesday, January 16, 2024	Sheet 22 of 24

3.3V

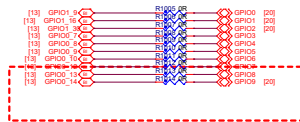

1.8V



