

# High Voltage Digital Motor Control Kit Quick Start Guide

Oct 2010



Fig1: TMDSHVMTRPFCKIT

The High Voltage Digital Motor Control (DMC) and Power Factor Correction (PFC) kit (TMDSHVMTRPFCKIT), provides a great way to learn and experiment with digital control of high voltage motors.

## The High Voltage Digital Motor Control Kit contains:

- F28035 controlCARD
- High Voltage DMC board with slot for the controlCARD
- 15V DC Power Supply
- AC power Cord, Banana Plug Cord, USB Cable
- CCS4 CD & USB Stick with Quick Start GUI and Guide



### WARNING

This EVM should be used only by qualified engineers and technicians who are familiar with the risks associated with handling electrical and mechanical components, systems and subsystems. The EVM operates at voltages and currents that can result in electrical shock, fire hazard and/or personal injury if not properly handled or applied. Users must use the equipment with necessary caution and employ appropriate safeguards to avoid serious injury. Users must not touch any part of the EVM while energized.



## Features of the High Voltage Motor Control and PFC Board:

- **3-Phase Inverter Stage** capable of sensorless and sensed field oriented control (FOC) of high voltage **ACI** and **PMSM** motor and trapezoidal & sinusoidal control of high voltage **BLDC** motor. 350V DC max input voltage and 1KW\* maximum load in the configuration shipped.
- **Power Factor Correction** stage rated for 750W\*, Takes rectified AC input (110V AC or 220V AC). 400V DC Max output voltage.
- **AC Rectifier** stage rated for 750W\* power. Accepts 110V AC or 220V AC input.
- **Aux Power Supply Module** (400Vto15V&5V module) generates 15V and 5V DC from rectified AC voltage or the PFC output (input Max voltage 400V, min voltage 90V).
- **Isolated CAN, SCI & JTAG**
- **Four PWM DAC's** to observe the system variables on an oscilloscope.
- Hardware Developer's Package available which includes schematics & bill of materials.

- Open source software available through **controlSUITE** for each type of the motor and control type.

*\*For detailed feature list and power ratings and safety related information refer to the kit's HW Reference guide*

The software available with the kit is pre-optimized for the motors that are available with the kit. The software is completely open source, and hence can be easily modified to tune and run a different motor. The following motors are available with the kit:

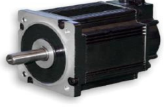
AC Induction Motor (HVACIMTR) <i>(220V , 3 phase AC, 0.25 HP)</i>	
PMSM Motor (HVPMSMMTR) <i>(200V, 3 Phase AC, 0.4KW)</i>	
BLDC Motor (HVBLDCMTR) <i>(160-170V, 3 Phase AC)</i>	

Note: The BLDC motor being shipped with the kit is rated for 160V in regions having mains supply > 140V AC a step down transformer needs to be used. Otherwise the GUI would give an over voltage error and disconnect from the controller.

### Hardware Overview

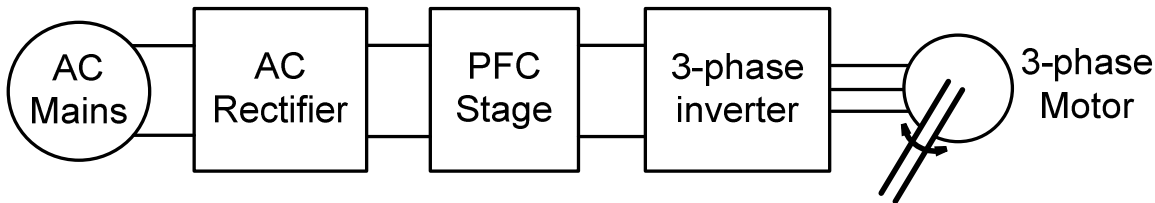

*Fig2: Block Diagram for a typical motor drive system using power factor correction*

Fig 2, illustrates a typical motor drive system running from AC power and various blocks that make up such a system. All these power/control blocks are present on the TMDSHVMTRPFCKIT board in form of macro blocks. Below is a list of all the macro blocks names and numbers present on the board and a short description of its function, Fig 3, shows the location of these block on the motor control board and a few key connector location.

- **HVDMC Main Board [Main]** – Consists of controlCARD socket, communications(isoCAN) block, Instrumentation(DAC's), QEP and CAP connection and routing of signals in b/w the macros and to the control card.
- **AC-Power Entry [M1]** – Takes input AC power from mains/wall power supply and rectifies it. This rectified voltage can then be used for input of the PFC stage or used to generate the DC bus for the inverter directly.
- **Aux Power Supply Module [M2]** – This module can take up to 400V input and generate 5V and 15V DC power. Rectified AC input can directly be connected to this module or output from the PFC stage can be used with appropriate jumper settings.
- **Iso-USB-to-JTAG Macro [M3]** – Provided on board isolated JTAG connection through USB to the host. Can also be used for SCI(isolated) communication for connection with GUI.
- **PFC-2PhiL Macro [M4]** - Two-phase interleaved PFC stage can be used to increase efficiency of operation.
- **Inverter2Ph-HV-3shunt Macro [M5]** - Three-phase inverter, provides the inverter stage to enable control of high voltage motors.

- **DC-PwrEntry Macro [M6]** - DC power entry, used to generate the 15V, 5V and 3.3V for the board from 15V DC power supply supplied with the kit.

*Nomenclature:* To easily find a component let's say a jumper they are referred with their macro number in the brackets. For example, [M3]-J1 would refer to the jumper J1 located in the macro M3 and [Main]-J1 would refer to the J1 located on the board outside of the defined macro blocks.

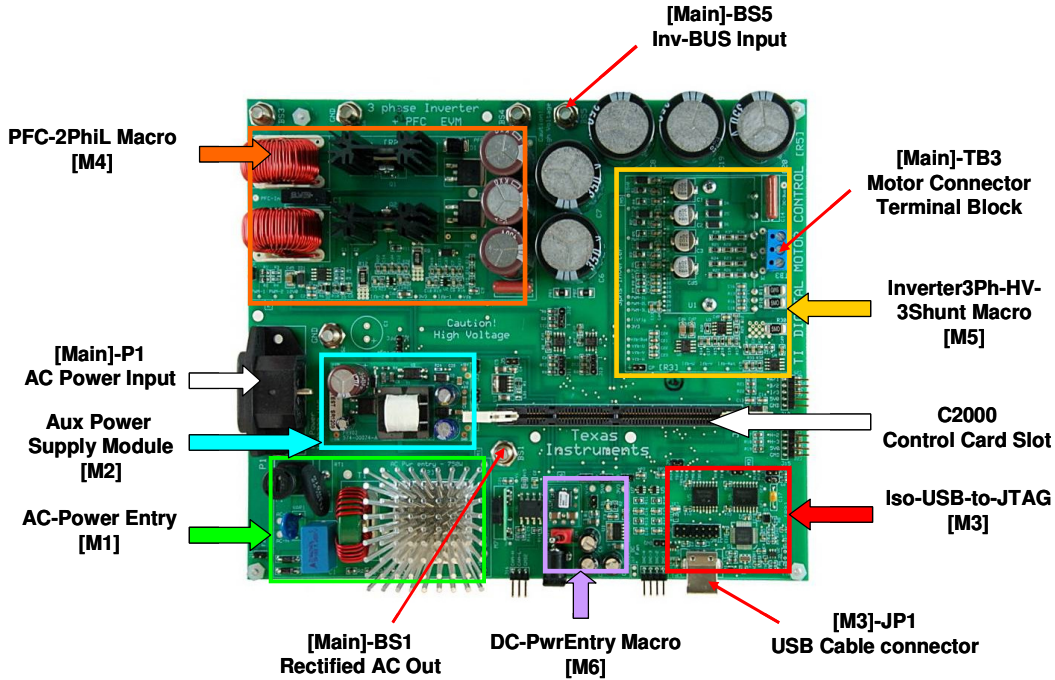

Fig3: HVDMCMTRPFCKit Board Macros

## Quick Start GUI

The kit comes with a GUI which provides a convenient way to evaluate the functionality of the kit and the F28035 device without having to learn and configure the underlying project software or install CCS. The interactive interface using sliders, buttons, textboxes and graphs enables easy demo of sensorless control of ACI, PMSM and BLDC Motor.

## Hardware Setup

**Note: Do not apply AC power to board before you have verified these settings!**

The kit ships with the control card inserted and the jumper and switch settings pre done for connecting with the GUI. However the user must ensure that these settings are valid on the board. To validate these settings and connect the motor the lid of the kit needs to be unscrewed. The lid can be screwed back once these settings are verified.

- 1) Make sure nothing is connected to the board, and no power is being supplied to the board.
- 2) Insert the Control card into the [Main]-J1 controlCARD connector if not already populated.
- 4) Make sure the following jumpers & connector settings are valid i.e.
  - a. [M3]-J4 is populated
  - b. [Main]-J11, J12 & J13 are populated with jumper b/w 1 and middle pin
  - c. [Main]-J3, J4 & J5, are populated
  - d. [Main]-J2 is populated with a jumper b/w bridge and the middle pin
  - e. Make sure that [M6]-J6, J7, J8 ; [Main]-J9 and [M3]-J1, J3, J5 are not populated
  - f. Banana cable b/w [Main]-BS1 and [Main]-BS5 is installed
- 5) Make sure that the following switches are set as described below on the F28035 control card to enable boot from flash and connection to the SCI
  - a. SW1 is in the OFF position

- b. SW2 on controlCARD, Position 1 = ON, Position 2 = ON
- 6) Connect a USB cable from [M3]-JP1 to the host computer. [M3]-LD1 would light up indicating that the USB is powered. Windows would then search for a driver for the device. If the computer has CCSv4 or prior versions of it installed which supported XDS100 emulator, Windows should be able to find the driver successfully. If not you would be prompted to install the driver. **Installing driver for USB to serial** : Do not let Microsoft search for the driver, instead browse to the following location on the USB stick drive shipped with the kit <Drive Name:\CDM 2.06.00 WHQL Certified>, windows should now be able to find the driver and would install it. If Windows still does not find the driver, you may have to repeat the process and point to the location pointed out previously. You may have to reboot the computer for the drivers to come into effect. Once installed you can check if the installation was completed properly by browsing to ControlPanel-> System->Hardware->Device Manager and looking for USB Serial Port under Ports(COM&LPT). Note this port number down.
- 7) Connect the motor you want to spin to the terminal block [Main]-TB3 on the board, (Only the Red, White and Black wire need to be connected to TB3, the Green wire is ground and should not be connected to the [Main]-TB3)
- 8) Re-fit the Lid on the kit.
- 9) Connect one end of the AC cord to [Main]-P1, Do not connect the other end to wall supply. Use an arrangement which allows for a switch b/w the wall supply and the board.

### Software Setup

The QSG GUI (HVMTRPFCKIT-GUIv1.exe) can be located in the drive that is shipped with the kit or once controlSUITE is installed at the following location:

```
controlSUITE\development_kits\HVMotorCtrl+PfcKit\~GUI\HVMTRPFCKIT-GUIv1.exe
```

The GUI is written in C# using Microsoft Visual Studio .NET with the source code located at:

```
controlSUITE\development_kits\HVMotorCtrl+PfcKit\~GUI\ ~Source
```

The GUI requires Microsoft .NET framework 2.0 or higher to run. Please ensure that this software is installed prior to running this program.

The kit ships with a F28035 Control Card which is pre-flashed with the code that enables interface to this GUI. The flashed code is optimized for running sensorless FOC on ACI and PMSM motor and sensorless trapezoidal control on BLDC motor that are available with the kit. Note that the performance of the motor with the flashed image is not a metric of quality of control and performance levels achievable using the TI DMC library. Please refer to the individual system software and corresponding literature for details. These can be downloaded through controlSUITE. The flash image can be re-flashed using CCSv4 if need be. The image can be found in the drive shipped with the kit or at the following location:

```
controlSUITE\development_kits\ HVMotorCtrl+PfcKit\~GUI\ HVMTRPFCKIT-GUI-FlashImagev1.out
```

### Running the GUI

- 1) Make sure all the jumper and connector setting are as described in the Hardware setup section.
- 2) Browse to and double click on *HVMTRPFCKIT-GUIv1.exe* The GUI window should pop up (Fig 4). If this is the first time you would have to go through a license agreement. The GUI is divided into the following sections
  - *Motor Select Box*: Allows the user to select the motor type that is connected to the board. It also notifies the type of control being used for each type of motor.
  - *Motor Control / Status Box*: This box contains sliders, textboxes, checkboxes, buttons and graphs that enable control of the motor and display various system parameters depending on the motor type selected.

- **Connection Box:** Contains control for setting up connection with the board. Clicking on *Setup Connection* opens a new window which lets you select the serial port and baud rate. Connect/Disconnect switch is used to establish SCI connection with the controller or terminate the connection. A checkbox displays the status of connection i.e. whether the connection is established/not established or broken.

*Note: Many variables on the GUI are referenced in per unit scale (pu). This is done as fixed point math is used by the controller to execute the control algorithm.*

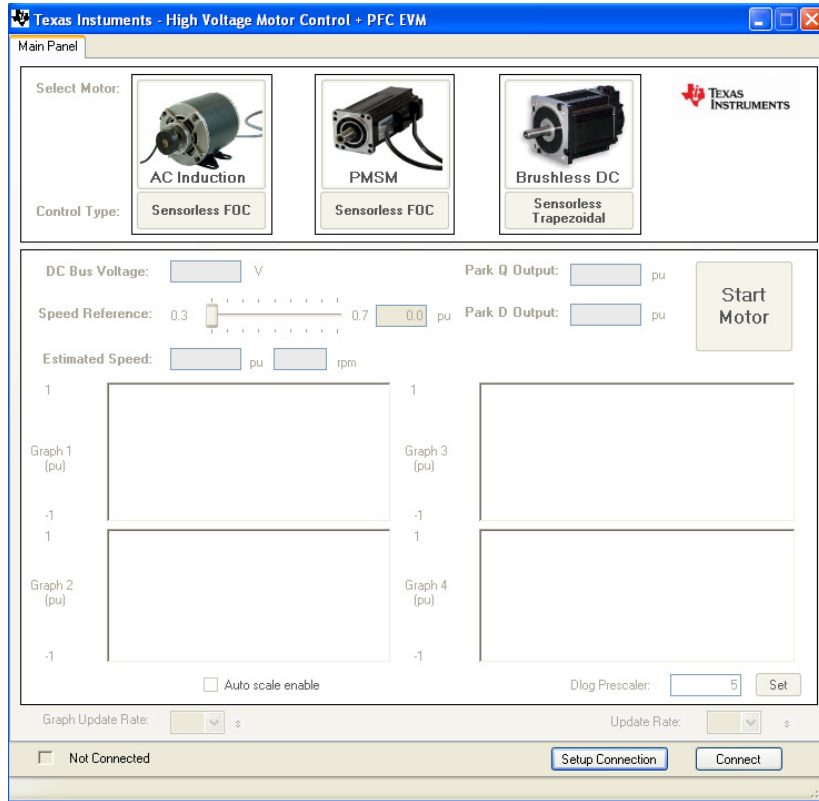

Fig4: GUI Startup

- 3) Now Click on “Setup Connection” and ensure the Baud Rate is set to 57600 and that the Boot on Connect Box is unchecked.
- 4) Now select the appropriate COM port. This can be found out by going to *Control Panel->System->Hardware tab->Device Manager->Ports(COM & LPT)*. And look for the one which is described as USB Serial Port or similar. Hit OK once done.

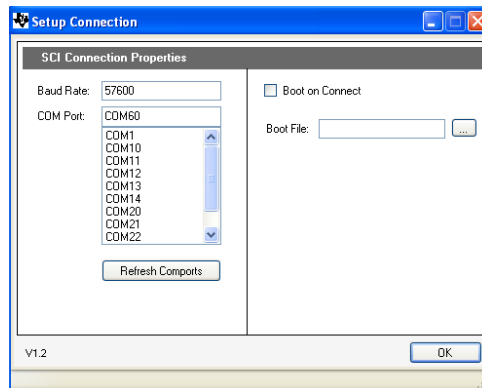
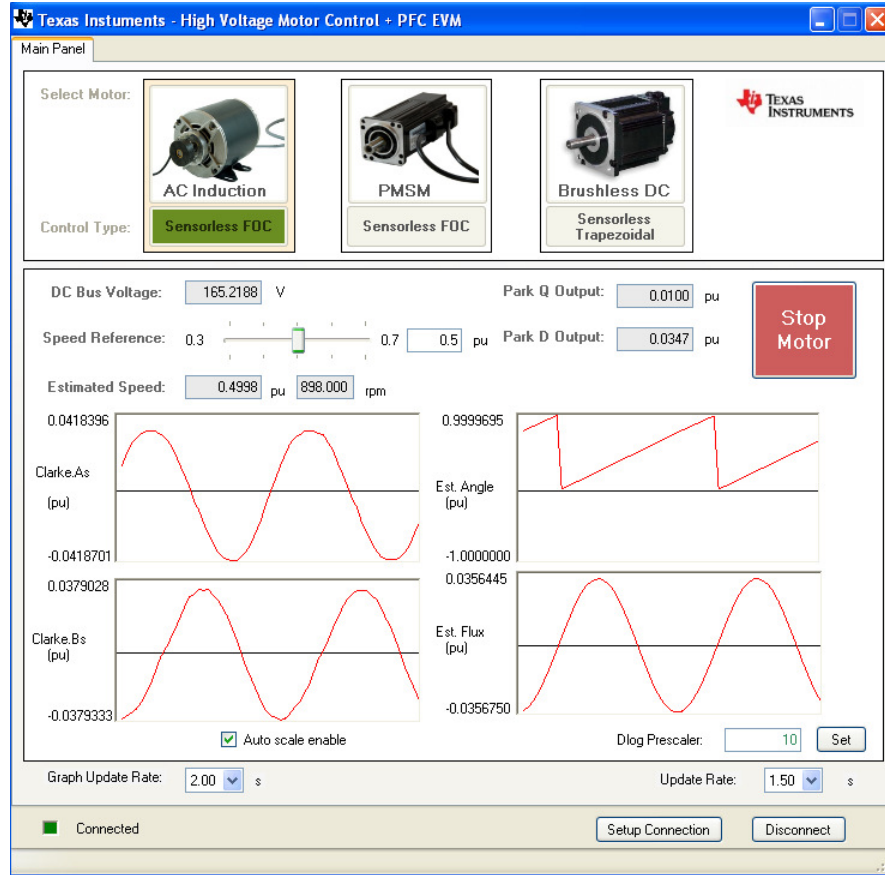

Fig5: GUI Setup Connections

- 5) Return to the GUI screen and now connect the other end of the AC power cord to mains/wall power outlet. Use an assembly such that a switch is in place between the mains supply and the board. For example this can be achieved using an extension cable.
- 6) Once the mains is connected the board would power up and you would see that the [Main]-LD1 on the board is green (indicating power) and LD3 (Red) on the board is blinking slowly indicating that code is running on the control card.
- 7) Now press “Connect” on the GUI window. If an incorrect image is flashed on the control card an error message on the bottom of the screen would be displayed. In this case it is recommended to switch of the Mains supply and reflash the control card with the correct image. Once the connection is established the LD2(Red) on the control card would start blinking and the Motor Select Panel would become active.
- 8) After the connection is established to the controller the type of motor can be selected by clicking on the motor image. Once the motor is selected the image of the motor and type of control being used would be highlighted and the motor select panel would gray out. If the selection needs to be changed the board needs to be power cycled as the code accepts motor type only once from the GUI for safety reasons in its lifetime. In case of connect disconnect without power cycling the board the previous motor selection is remembered. Also note if BLDC motor is being used with wall supply of >140V AC a step down transformer must be used as the BLDC motor is rated for 160V, otherwise an over voltage condition flag would be displayed.
- 9) The motor control/status box would now become active. The variables being displayed in the box would change depending on the type of motor selected. Following is a description of each of these controls:
  - **DC Bus Voltage Textbox:** Textbox displays the rectified AC voltage. This voltage should be around 154V for 110V AC supply but can go as high as 180V depending on line conditions. For 220 AC line this voltage would be close to 311V.
  - **Start / Stop Button:** This button can be used to start and stop the motor. The color & text of the button changes depending on what action can be taken. Please provide for enough time for the motor to respond to the command.
  - **Speed Reference Slider & Textbox:** Speed of the motor can be varied using this slider and the textbox. The range of speed reference slider changes depending on the motor type selected. By default when the motor is started a 0.3pu speed reference is provided. To change the speed the slider can be moved or a value entered into the textbox. The textbox changes color as value is being typed depending on if it can accept that value. A value can only be entered if it is displayed as green. Once the speed ref is changed the motor ramps up to the reference speed. Time taken for the motor to reach the speed would depend on motor type. Please provide for enough time for motor to ramp up to this speed. Also note that the ramp is deliberately slow in the flashed image, and can be easily modified in the code for desired performance levels and characteristics.
  - **Estimated Speed Textboxes:** These text boxes display the speed of the motor as estimated by the sensorless algorithm. Both per unit and absolute rpm values are displayed. Note for different type of motor the rpm speed may vary for the same per unit speed reference as the maximum rated speed of the motors are different.
  - **Park Q & Park D output Textboxes** (for ACI and PMSM motors only) These two text boxes display the park Q and park D values as computed by the sensorless algorithm. These can be observed to change as the motor is loaded. Note for the PMSM motor Park D value would remain close to zero.
  - **Graph Windows:** Upto Four graph windows can display data captured from the controller. Depending on the motor type this data would change. For example for an ACI motor the graphs would display the estimated flux, estimated angle and the leg currents sensed(Fig 6). For BLDC the back EMF's sensed would be observed, and for PMSM the Phase voltage, phase Duty, estimated angle and Alpha back emf are displayed.
  - **AutoScale Checkbox:** Check this box to autoscale the graph to get more meaningful waveforms.
  - **Dlog Prescalar Textbox:** This value is used by the Data Logging module running on the controller to sample the data for plotting. Greater this value more cycles are visible in the graph window.

However as fewer points are sampled this reduces the accuracy. This value needs to be changed depending on the motor type and speed reference chosen. By default a value of 5 is pre-selected.

- **Graph Update Rate Select:** This is the rate at which the GUI asks the controller for data to plot on the graphs. Note unless you select a rate the GUI does not ask the controller for any data and hence nothing would be plotted on the graphs. Also note that the data is captured in real time however only a small snapshot of it is displayed on the graph window.
- **Update Rate Select:** This is the rate of how frequently the data for the textboxes, buttons and sliders is updated from the GUI to the controller and vice versa.



*Fig 6: GUI Running ACI Motor*

- 10) Once the start button is clicked the motor accelerates to the speed reference value and the speed loop is closed. The time taken for motor to ramp up to a particular speed would depend on motor type. Hence provide for enough time for the motor to ramp up to the speed set. The speed can be varied by moving the slider or entering value in the textbox. The motor can be stopped and started number of times. Note that each time the motor is stopped you may observe a surge in the DC bus voltage.

*Note: If LD2 on the control card stops blinking and the GUI stops updating, this indicates that GUI has lost connection to the board. In this case it is recommended to click on the disconnect button, wait for the GUI status to change to disconnected and then click on connect. If the motor was spinning before GUI lost connection a connect would force the motor to stop.*

- 11) The parameters in the preflashed image have been tuned for light loads over the range for DC bus voltage generated from 110V AC line or 220v AC line. The motor can be loaded and the result in case of load observed on the GUI.
- 12) Once finished evaluating, click on the stop button to stop the motor. Once motor comes to a full stop click on disconnect. Now Switch off/ Unplug the AC power. As the capacitors are charged the LED on

