

QSPI

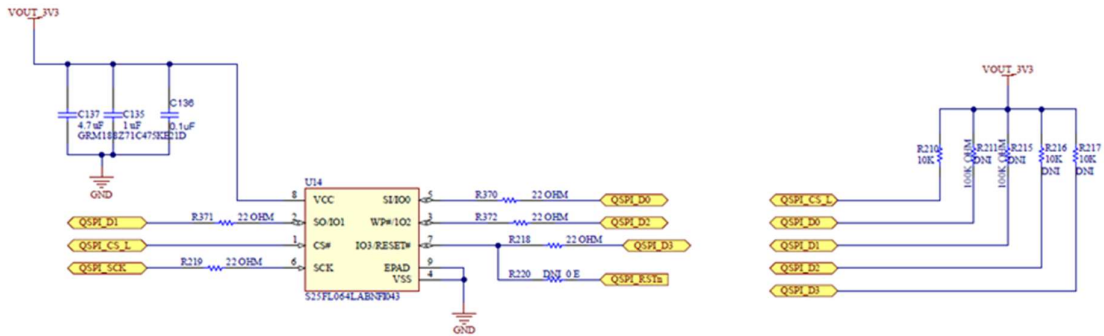

1. R211,R215,R216,R220 Mounted
2. QSPI_RSTn and QSPI_D3 is shared - one pullup present on RSTn

Pin muxing:

MCU pin	Signal
J2	QSPI_CLK
F3	QSPI_CSn0
L2	QSPI_D0
G1	QSPI_D1
J3	QSPI_D2
H2	QSPI_D3

At MCU_PORz pin(P2) , R313: When the **PORz switch** is pressed, the signal goes low, and upon release, it returns to 3.3V. However, the board does not reboot and instead enters the UART bootloader.

